



# HISTORIC DISTRICT COMMISSION APPLICATION FOR WORK APPROVAL

City of Detroit - Planning & Development Department  
2 Woodward Avenue, Suite 808  
Detroit, Michigan 48226

<b>APPLICATION ID</b>
HDC2024-00623

## PROPERTY INFORMATION

<b>ADDRESS(ES):</b> 2761 E. Jefferson Ave, Ste 302
<b>HISTORIC DISTRICT:</b> New Center Area

**SCOPE OF WORK: (Check ALL that apply)**

- |  |  |                                       |   |   |                                |
|--|--|---------------------------------------|---|---|--------------------------------|
| <input checked="" type="checkbox"/> Windows/ Doors | <input type="checkbox"/> Walls/ Siding | <input type="checkbox"/> Painting     | <input checked="" type="checkbox"/> Roof/Gutters/ Chimney | <input checked="" type="checkbox"/> Porch/Deck/Balcony                              | <input type="checkbox"/> Other |
| <input type="checkbox"/> Demolition                | <input type="checkbox"/> Signage       | <input type="checkbox"/> New Building | <input type="checkbox"/> Addition                         | <input type="checkbox"/> Site Improvements (landscape, trees, fences, patios, etc.) |                                |

<p><b>BRIEF PROJECT DESCRIPTION:</b> Exterior renovation of home, new dormers. front and rear porch.</p>
--

## APPLICANT IDENTIFICATION

<b>TYPE OF APPLICANT:</b> Architect/Engineer/Consultant			
<b>NAME:</b> Timothy Flintoff		<b>COMPANY NAME:</b> 4545 Architecture	
<b>ADDRESS:</b> 2761 E. Jefferson Ave, Ste 302		<b>CITY:</b> Detroit	<b>STATE:</b> MI <b>ZIP:</b> 48207
<b>PHONE:</b> +1 (313) 450-4545		<b>EMAIL:</b> tim.flintoff@4545architecture.com	

## I AGREE TO AND AFFIRM THE FOLLOWING:

- I understand that the failure to upload all required documentation may result in extended review times for my project and/or a denied application.
- I understand that the review of this application by the Historic District Commission does not waive my responsibility to comply with any other applicable ordinances including obtaining appropriate permits (building, sign, etc.) or other department approvals prior to beginning the work.
- I hereby certify that the information on this application is true and correct. I certify that the proposed work is authorized by the owner of record and I have been authorized to make this application as the property owner(s) authorized agent.

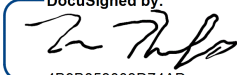
DocuSigned by:  
  
 4B98853003D74AD...

10/21/2024

SIGNATURE

DATE

**NOTE: Based on the scope of work, additional documentation may be required. See [www.detroitmi.gov/hdc](http://www.detroitmi.gov/hdc) for scope-specific requirements.**

## PROJECT DETAILS – TELL US ABOUT YOUR PROJECT

**Instructions: Add project details using the text box in each section. If your details exceed the space provided, attach the details via the attachment icon for that section.**

**ePLANS PERMIT NUMBER:**

(only applicable if you've already applied for permits through ePLANS)

N/A

### GENERAL

**1. DESCRIPTION OF EXISTING CONDITION**

*Please tell us about the current appearance and conditions of the areas you want to change. You may use a few sentences or attach a separate prepared document on the right. (For example, "existing roof on my garage is covered in gray asphalt shingles in poor condition.")*



**2. PHOTOGRAPHS**

*Help us understand your project. Please attach photographs of all areas where work is proposed.*



**3. DESCRIPTION OF PROJECT**

*In this box, tell us about what you want to do at the areas described above in box #1. (For example, "Install new asphalt shingle roofing at garage.")*



**4. DETAILED SCOPE OF WORK**

*In this box, please describe all steps necessary to complete the work described in box #3. (For example, "remove existing shingles, replace wood deck as necessary, replace wood eaves, install roof vents, replace rotted fascia boards, paint, clean worksite.")*



**5. BROCHURES/CUT SHEETS**

*Please provide information on the products or materials you are proposing to install. For example, a brochure on the brand and color of the shingles proposed.*

## ADDITIONAL DETAILS

<p><b>6. WINDOWS/DOORS</b> <i>Detailed photographs of window(s) and/or door(s) proposed for replacement showing the condition of the interior and exterior of the window(s) and/or door(s)</i></p>	



October 21, 2024

708 Pallister St.,  
Detroit, MI 48202

RE: 708 Pallister Exterior Renovations, District Historic Commission Submission

### Project Narrative

708 Pallister is a single family home in the New Center Area historic district. It is located in the middle of the pedestrian-only block of Pallister St., between 3rd Ave. and Bethune Ct. The structure is two stories, with a traditional hip roof and covered porch entry, and a single street-facing dormer. It features painted horizontal wood siding on the first floor exterior, with painted wood shake above, on traditional wood framing. The street-facing south elevation also features a bay window on the first floor, adjacent to the existing covered porch. The structure is approximately 1557 GSF, plus an attic and basement. The property also has a detached, single-story 2 car garage that is approximately 500 GSF. The project consists of exterior repair and refurbishment of existing wood building elements, window repair and replacement, and the construction of a new wood deck in the backyard. Where it is necessary to replace damaged existing elements, in-kind materials will be used. All wood elements will be painted in accordance with the appropriate Detroit Historic Commission Color System.

The existing masonry front porch is to remain, and be repaired as required. The masonry stair to the east of the porch will be removed, and replaced with a masonry stair on the south side of the porch, in line with the existing walkway. New wrapped wood posts will be installed on the porch, as well as a wood handrail; these will be painted with appropriate colors in coordination with the house. The existing below-grade basement entry door in the rear will be infilled for the construction of the new rear deck. Bricks which match the existing structure will be used. Two windows on the north elevation are to be removed and replaced with a sliding glass door. Two existing window openings (one on the north facade and one on the east) are to be modified to accommodate interior configuration changes that will be completed under a separate building permit. The windows will be replaced with aluminum-clad wood single-hung windows. An existing window and door on the north facade will also be infilled to accommodate these changes, using in-kind materials. Three new dormers will be constructed; one on the north, east, and west facades. The roofing and siding of the dormers will be the same material and color as the existing dormer.

# 4545 architecture

The garage siding will be repaired with in-kind materials as required, and it will be painted the same colors as the house. Wood roof joists and sheathing in the garage will be replaced as required, as well as the ice and water barrier. Roof shingles that match the existing will be used.

# 4545 architecture

October 21, 2024

708 Pallister St.,  
Detroit, MI 48202

RE: 708 Pallister Exterior Renovations, Historic District Commission Submission



Front (South) Elevation

# 4545 architecture



Rear (North) Elevation

# 4545

architecture



Side (East) Elevation



# 4545

architecture



Side (West) Elevation

# 4545 architecture



Front Bay Window Detail



Front Window Detail

# 4545 architecture



Typical Window Detail

# 4545 architecture



Front Porch Soffit Detail

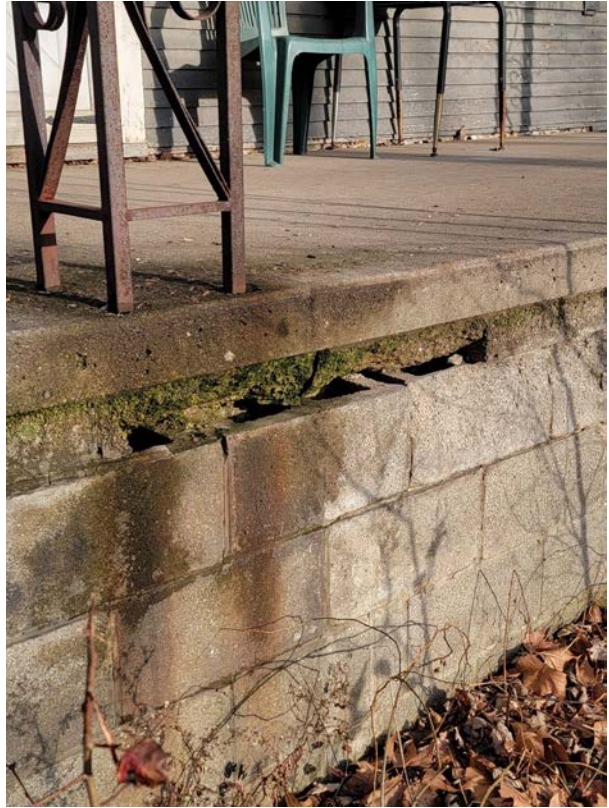

Typ. Damage to Front Porch



Front Porch Stair Detail

# 4545 architecture



Front Dormer Detail



Rear Soffit Detail

---

4545 Commonwealth Street, Detroit, MI 48208

e | [tim.flintoff@4545architecture.com](mailto:tim.flintoff@4545architecture.com) • c | 248.320.6098 • w | [4545architecture.com](http://4545architecture.com)

# 4545

architecture



Basement Door Detail

# 4545

architecture



Rear Deck Details

# 4545 architecture



Garage Front (South) Elevation



# 4545

architecture



Garage Side (West) Elevation

# 4545

architecture



Garage Alley (North) Elevation

# 4545 architecture



House and Garage Roof



## GLIDING WINDOWS

Tables of Sizes .....	114
Specifications .....	115
Grille Patterns .....	115
Window Details .....	116
Product Performance .....	197

# GLIDING WINDOWS

## FEATURES

### FRAME

**A** The exterior of the frame is covered with fiberglass to maintain an attractive appearance while minimizing maintenance.

**B** Wood frame members are treated with a water-repellent preservative for long-lasting protection and performance.

**C** Flexible bulb weatherstrip and spring-tension vinyl are installed at the factory, and help provide a tight seal between the sash and frame.

**D** Fold-out-and-lock installation flanges accommodate 4 1/2" (114) and 4 1/8" (105) wall construction.

### SASH

**E** For improved ventilation, both sash are operable. Rigid vinyl encases the entire sash. A vinyl weld protects each sash corner for superior weathertightness to maintain an attractive appearance and minimize maintenance.

**F** Natural wood sash members help provide excellent structural stability and energy efficiency.

**G** Interior stops are unfinished pine. Low-maintenance prefinished white, Sandtone, dark bronze and black\* interiors are also available.

### Delrin® Glides



Teflon®-infused Delrin glides are self-lubricating and require only 8 lbs/3.6 kg of force to operate. A stainless steel spring within the glide provides years' of reliable operation – even in harsh environments.



### GLASS

**H** In addition to stainless steel glass spacers, black or white glass spacers are now available to allow the spacer to blend in with the unit color.

**I** High-Performance options include:

- Low-E4® glass
- Low-E4 HeatLock® glass
- Low-E4 SmartSun™ glass
- Low-E4 SmartSun HeatLock glass
- Low-E4 Sun glass

Tempered and other glass options are available. Contact your Andersen supplier.

A removable translucent film helps shield the glass from damage during delivery and construction, and simplifies finishing at the job site.

### Patterned Glass

Patterned glass options are available. See page 12 for more details.

### HARDWARE

#### Locking System

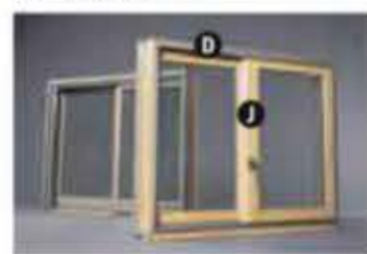

**J** For an added measure of security and increased weathertightness, the locking system pulls the sash firmly closed while pushing the sash tight to the side jambs. This lock is single-point on 2' (610) tall windows, two-point on 3' (914) tall windows, and three-point on 3'-6" (1067), 4' (1219) and 5' (1524) tall windows.

## EXTERIOR & INTERIOR OPTIONS

### EXTERIOR COLORS



### INTERIOR OPTIONS



## HARDWARE OPTIONS Sold Separately



Rotating Sash Handle

Antique Brass | Black | Bright Brass  
Brushed Chrome | Distressed Bronze  
Distressed Nickel | Oil Rubbed Bronze  
Polished Chrome | **Satin Nickel**  
Stone | White

Bold name denotes finish shown.

### HARDWARE FINISHES



\*Visit [andersenwindows.com/warranty](http://andersenwindows.com/warranty) for details.

\*\*Sandtone interior available with Sandtone, canvas, Terratone, dark bronze and black exteriors.

†Products with white, dark bronze and black interiors have matching exteriors.

‡Delrin® and Teflon® are registered trademarks of E.I. du Pont de Nemours and Company.

Dimensions in parentheses are in millimeters.

Printing limitations prevent exact replication of colors and finishes. See your Andersen supplier for actual color and finish samples.

Naturally occurring variations in grain, color and texture of wood make each window one of a kind. All wood interiors are unfinished unless a finish is specified. Distressed bronze and oil rubbed bronze are "living" finishes that will change with time and use.



# 400 SERIES

## ACCESSORIES Sold Separately

### FRAME

#### Extension Jambs



Standard jamb depth is 4 9/16" (116). Extension jambs are available in unfinished pine, or prefinished white, dark bronze and black. Some sizes may be veneered.

Factory-applied and non-applied interior extension jambs are available in 1/16" (1.5) increments between 5 1/16" (129) and 7 1/16" (181).

### HARDWARE

#### Passive Sash Handle



Attaches to the passive sash to aid in operation. Available in Sandtone.

#### Window Opening Control Device



A window opening control device is available, which limits sash travel to less than 4" (102) when the window is first opened. Available in factory applied, or as a field-applied kit in stone or white. Device shown above on a 200 Series gliding window.

### INSECT SCREENS

Choose fixed, full insect screens or gliding pass-through insect screens. Frames are available in colors to match product exteriors.

#### TruScene® Insect Screens

Andersen® TruScene insect screens let in over 25% more fresh air\* and provide 50% greater clarity than conventional Andersen insect screens, all while keeping out unwanted small insects.

#### Conventional Insect Screens

Conventional insect screens have charcoal powder-coated aluminum screen mesh.

### GRILLES

Grilles are available in a variety of configurations and widths. For gliding window grille patterns, see page 115.

### EXTERIOR TRIM

Available with Andersen exterior trim. See exterior trim section starting on page 175.

### CAUTION:

- Painting and staining may cause damage to rigid vinyl.
- 400 Series windows in Terratone color may be painted any color lighter than Terratone color using quality oil-based or latex paint.
- Do not paint 400 Series windows in white, canvas, Sandtone, dark bronze, forest green or black exterior colors.
- Andersen does not warrant the adhesion or performance of homeowner-applied paint over vinyl or other factory-coated surfaces.
- For vinyl painting instructions and preparation, contact your Andersen supplier.
- Do not paint weatherstrip.
- Creosote-based stains should not come in contact with Andersen products.
- Abrasive cleaners or solutions containing corrosive solvents should not be used on Andersen products.

\*TruScene insect screens let in over 25% more fresh air than standard Andersen fiberglass insect screens. Dimensions in parentheses are in millimeters.

# GLIDING WINDOWS

## Gliding Window Details

Scale 1 1/2" (38) = 1'-0" (305) – 1:8

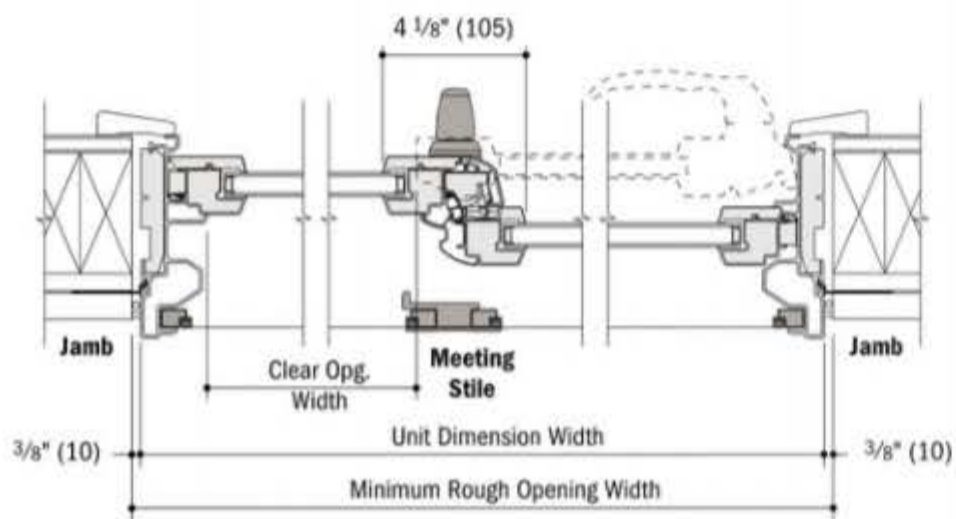

Horizontal Section

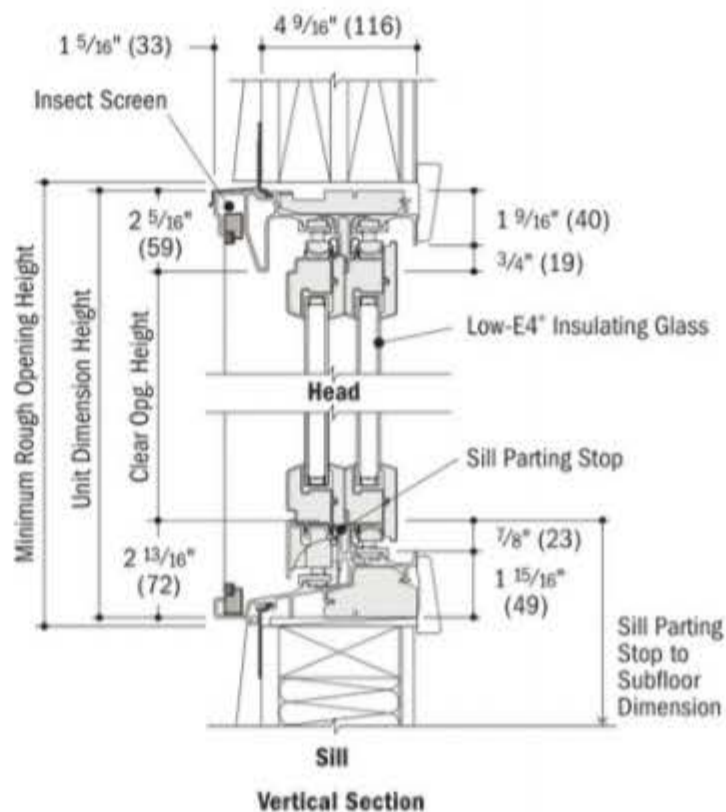

Vertical Section

## Separate Rough Openings Detail

Scale 1 1/2" (38) = 1'-0" (305) – 1:8

To meet structural requirements or to achieve a wider joined appearance, windows may be installed into separate rough openings having vertical support (by others) in combination with Andersen® exterior filler and exterior vinyl trim.

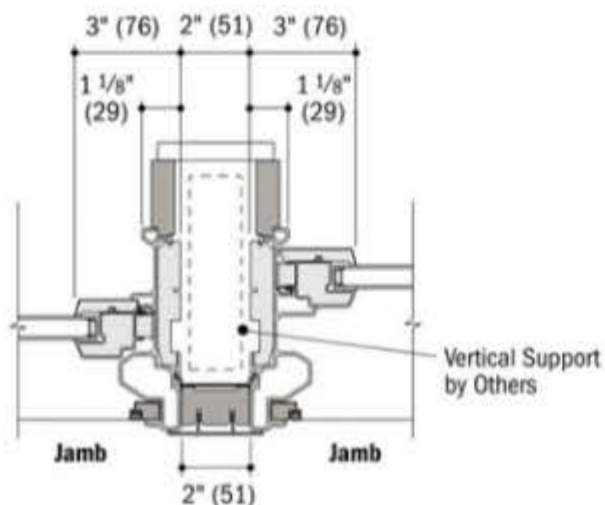

Horizontal Section  
Gliding and Gliding

- Light-colored areas are parts included with window. Dark-colored areas are additional Andersen® parts required to complete window assembly as shown.
- Minimum rough openings may need to be increased to allow for use of building wraps, flashing, sill panning, brackets, fasteners or other items. See installation information on pages 210-211.
- Details are for illustration only and are not intended to represent product installation methods or materials. Refer to product installation guides at andersenwindows.com.
- Consult with an architect or structural engineer regarding minimum requirements for structural support members between adjacent rough openings.
- Dimensions in parentheses are in millimeters.



**FRENCHWOOD®  
HINGED INSWING  
PATIO DOORS**

- Table of Sizes ..... 152-153
- Specifications ..... 154
- Custom Sizing ..... 155
- Grille Patterns ..... 155
- Door Details ..... 156-157
- Joining Details ..... 158
- Combination Designs ..... 181
- Product Performance ..... 197

**CUSTOM SIZING**  
in 1/8" (3) increments 

Dimensions in parentheses are in millimeters.

# FRENCHWOOD® HINGED INSWING PATIO DOORS



## 400 SERIES

### FEATURES

#### FRAME

**A** The sill is made with three-piece construction. The subsill is made of Fibrex® material, and the sill step is solid oak. The exterior sill member is made of extruded aluminum with an attractive wear-resistant, heat-baked finish in neutral gray. This combination of materials combines durability and low maintenance with excellent insulating characteristics.

**B** All basic exterior frame members are fiberglass reinforced composite, which maintains an attractive appearance while minimizing maintenance.

**C** The exterior frame members are attached to a water-repellent preservative-treated wood subframe for long-lasting protection and performance. The subframe is grooved to accept extension jambs.

#### PANEL

**D** Panel interior surfaces are unfinished pine veneer. Unfinished maple or oak veneers are available as options. Low-maintenance prefinished white interiors are also available.

Hinged inswing operating panels are left-hand active, right-hand active or two-panel active-passive jamb hinged.



**E** The exterior of the wood door panel is protected with a long-lasting urethane base finish available in white, Sandtone, Terratone and forest green.

**F** A factory-applied, one-piece compression-type rubber weatherstrip continues in one plane around the panel to provide maximum effectiveness against water and air infiltration. Corners of the weatherstrip are welded to eliminate gaps between the panel and the frame/sill shoulder.

#### Mortise-and-Tenon Joints



Mortise and tenon joints prevent panel sag and maintain smooth operation.

#### GLASS

**G** In addition to stainless steel glass spacers, black or white glass spacers are now available to allow the spacer to blend in with the unit color.

**H** Panels are silicone bed glazed and finished with an interior wood stop.

#### High-Performance options include:

- Low-E4® tempered glass
- Low-E4 HeatLock® tempered glass
- Low-E4 SmartSun™ tempered glass
- Low-E4 SmartSun HeatLock tempered glass
- Low-E4 Sun tempered glass

Additional glass options are available. Contact your Andersen supplier.

A removable translucent film helps shield the glass from damage during delivery and construction, and simplifies finishing at the job site.

Patterned glass options are available. See page 12 for more details.

### EXTERIOR & INTERIOR OPTIONS

#### EXTERIOR COLORS



#### INTERIOR OPTIONS



Naturally occurring variations in grain, color and texture of wood make each window one of a kind. All wood interiors are unfinished unless a finish is specified. Printing limitations prevent exact replication of colors and finishes. See your Andersen supplier for actual color and finish samples.

### HARDWARE OPTIONS Sold Separately



#### HARDWARE FINISHES



#### FSB® HARDWARE & FINISHES



Mix-and-match interior and exterior style and finish options are available; excludes FSB hardware. Bright brass and satin nickel finishes feature a 10-year limited warranty. Tribeca and Albany hardware are zinc die cast with powder-coated durable finish. Other hardware is solid forged brass. Distressed bronze and oil rubbed bronze are "living" finishes that will change with time and use.

\*Visit [andersenwindows.com/warranty](http://andersenwindows.com/warranty) for details.  
 \*\*FSB style 1102 is not available in black anodized aluminum.  
 FSB® is a registered trademark of Franz Schneider Brakel GmbH & Co. Matching hinges are available for inswing patio doors.

#### Blinds-Between-the-Glass



Blinds-between-the-glass are available for select hinged patio door sizes when ordered with Low-E4® tempered glass, and a pine or prefinished white door interior and any of our four exterior colors. White 1/2" (13) aluminum slot blinds come mounted between two panes of insulated glass in a dust-free environment. Blinds are magnetically controlled and can be tilted, raised and lowered using low-profile controls. Smooth, simple operation allows for customized light and privacy control. Available in 2768, 27611, 3168, 31611, 5068, 50611, 6068, 60611, 9068 and 90611 door sizes.

#### HARDWARE

##### Hinges

Adjustable hinges are standard on inswing patio doors and have ball-bearing pivots for smooth, frictionless movement. Feature easy horizontal and vertical adjustment, plus quick-release for easy panel removal. The release feature is ideal for transporting large units up stairs or to other hard-to-reach areas. Gold dust finish is standard on wood interior doors. For units with prefinished white interior, white is standard. Also available in finishes that coordinate with the hardware.

##### Multi-Point Locking System

The multi-point locking system, with a hook bolt above and below the center dead bolt, provides a weathertight seal and enhanced security.

### ACCESSORIES Sold Separately

#### FRAME

##### Interior Extension Jambs

Standard jamb depth is 4 9/16" (116). Pine, maple and oak veneers, or prefinished white extension jambs are available in 1/8" (1.5) increments between 5 1/16" (129) and 7 1/8" (181). Interior extension jambs on inswing units will restrict the full opening of the door.

##### Exterior Extension Jambs\*

Exterior extension jamb system is available for the following wall thicknesses: 5 1/4" (133), 6 9/16" (167) and 7 9/16" (192). In walls over 4 1/2" (114), the exterior sill extender and exterior extension jamb system allows the unit to be installed flush to the interior, so the hinged doors will open flat against the interior wall. Color matched to the exterior of the finished unit, this system provides a low-maintenance, finished exterior appearance. An extended double-insect screen track is available for jamb-hinged doors that require gliding insect screens. Exterior extension jamb kits are available with or without the double-insect screen track.

##### Threshold



A maple or oak threshold is available for finishing the interior of the sill.

##### Ramped Sill Insert



Ramped sills in maple or oak provide smooth transition from interior to exterior. Ramped sill cannot be used with insect screens. Check with local and federal officials to determine if product meets accessibility codes. Shown with a Frenchwood® gliding patio door.

##### Sill Support



An aluminum sill support is designed to lock into a channel under the sill and tie back into the wall. This offers support to the outermost sill section when needed. Available in a neutral gray finish.

#### HARDWARE

##### Exterior Keyed Lock



A six-pin key cylinder lock is available in styles and finishes that coordinate with the hardware. This lock allows the hinged patio door to be locked and unlocked from the exterior.

##### Handle Extension



Extends interior door handle an additional 1" (25) from the door interior panel to accommodate blinds or shades. Kit includes one handle extender and spindle. A second extender may be added to increase the length an additional 1" (25) to a 2" (51) total extension. Extenders are available in finishes that coordinate with hardware.

##### Strike Plate Extensions

Bright brass, antique bronze, polished chrome, oil rubbed bronze, brushed chrome and satin nickel strike plate extensions are available for the following wall thicknesses: 5 1/8" (133), 6 9/16" (167), 7 1/8" (181) and 7 9/16" (192).

##### Construction Lock



This hardware can be used on all Andersen® hinged doors to help secure the structure during the construction phase of the project. It features an undersized escutcheon plate, which makes on-site finishing easier.

##### Panel Stop



This hinged door panel stop helps prevent wall damage when opening the inswing door. Available in finishes that coordinate with the hardware.

#### GLASS

##### Andersen® Art Glass

Andersen art glass panels come in a variety of original patterns. Available for stationary panels, sidelights and transoms. See art glass section starting on page 173 for more information or visit [andersenwindows.com/artglass](http://andersenwindows.com/artglass).

#### INSECT SCREENS

All insect screens have a long-lasting fiberglass screen mesh with a charcoal finish, and frames are color matched to the exterior of the door unless otherwise specified.

##### Gliding Insect Screen

Available for all two- and three-panel doors. Features Delrin® material injection-molded bottom rollers with self-contained leveling adjusters. A double insect screen track is required for two-panel active-passive or passive-active doors. Gliding insect screens are not available for 4' (1219)-wide doors.

##### Double-Insect Screen Track



An extended insect screen track is required for two-panel active-passive or passive-active hinged doors that use gliding insect screens.

##### Hinged Insect Screens

Available for single-panel hinged doors, and two-panel active-passive or passive-active doors.

#### GRILLES

Available in a variety of configurations and widths. See page 155.

#### EXTERIOR TRIM

Available with Andersen exterior trim. See exterior trim section starting on page 175.

#### SIDELIGHTS & TRANSOMS

Andersen Frenchwood patio door sidelights and transoms feature elegant lines that match our Frenchwood hinged patio doors. See pages 159-162 for details.

#### CAUTION:

- Painting and staining may cause damage to rigid vinyl.
  - Do not paint 400 Series patio doors in white, canvas, Sandtone, dark bronze, forest green or black exterior colors.
- See page 143 for a complete list of painting, staining and cleaning cautions.

\*Delrin® is a registered trademark of E.I. du Pont de Nemours and Company. Andersen patio doors are not intended for use as entrance doors. Dimensions in parentheses are in millimeters.

\*Exterior extension jambs for hinged inswing patio doors must be applied before installing into opening.  
 \*\*Visit [andersenwindows.com/warranty](http://andersenwindows.com/warranty) for details.



**Custom Sizes and Specification Formulas**

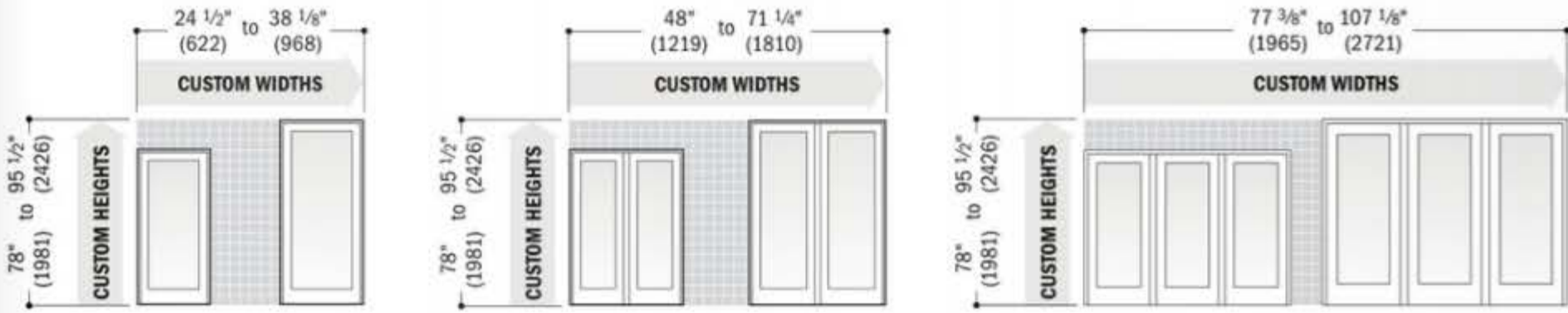

<b>Clear Opening</b> 	Height = height - 4.22" (107) Single-Panel Width = width - 5.744" (145) Two-Panel, two panels open Width = width - 7.394" (187) Two-Panel, one panel open Width = (width - 10.550" (267)) + 2 Three-Panel Width = (width - 16.106" (409)) + 3	<b>Minimum R.O.</b> 	Width = width + 3/4" (19) Height = height + 1/2" (13)	<b>Unobst. Glass</b> 	Single-Panel Width = width - 11.22" (285) Height = height - 16.05" (408) Two-Panel Width = width - 21.5" (546) Height = height - 16.05" (408) Three-Panel Width = width - 32.55" (827) Height = height - 16.05" (408)
--------------------------	---	-------------------------	--	--------------------------	---



Available in 1/8" (3) increments between minimum and maximum widths and heights. Some restrictions apply. Measurement guide can be found at [andersenwindows.com/measure](http://andersenwindows.com/measure).

• Clear opening width formulas are based on panel(s) in a 90° open position.  
 • Dimensions in parentheses are in millimeters.  
 • **Clear Opening** formulas provide dimensions for determining area available for egress. Vent opening, or area available for passage of air, is equal to clear opening. **Minimum R.O.** (minimum rough opening) formulas provide minimum rough opening width and height dimensions. **Unobst. Glass** (unobstructed glass) formulas provide dimensions for determining area available for passage of light.

**Grille Patterns**

	Prairie A	Colonial	Modified Colonial	Modified Colonial with Simulated Meeting Rail	Tall Fractional	Tall Fractional with Simulated Meeting Rail	Short Fractional	Short Fractional with Simulated Meeting Rail
<b>Frenchwood® Gliding and Hinged Inswing Patio Doors</b>								

**Number of lights and overall pattern varies with panel size. Patterns not available in all configurations.** Specified equal light and custom patterns are also available. For more grille options, see page 14 or visit [andersenwindows.com/grilles](http://andersenwindows.com/grilles).

**Interior Extension Jamb**

Use of interior extension jambs or drywall return will restrict panel operation on jamb-hinged patio doors. Jamb-hinged patio doors must be installed flush to the interior to achieve full panel operation.

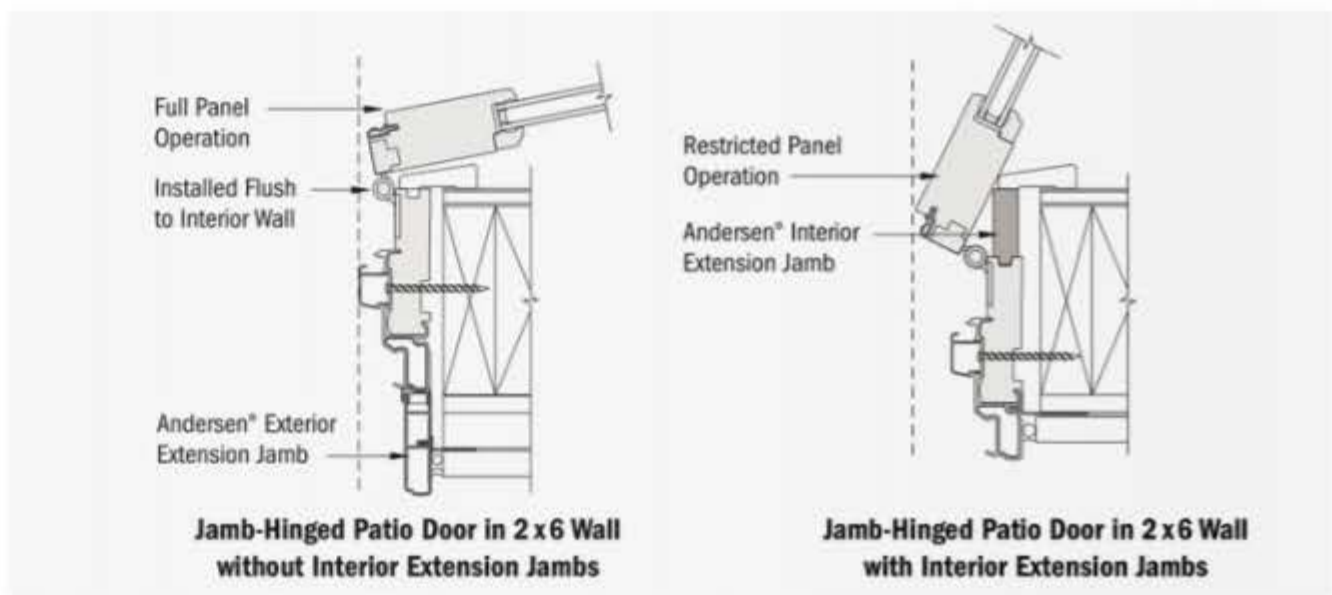

400 Series Frenchwood® Hinged Inswing Patio Doors

# FRENCHWOOD® HINGED INSWING PATIO DOORS

## Frenchwood® Hinged Inswing Patio Door Details

Scale 1 1/2" (38) = 1'-0" (305) – 1:8

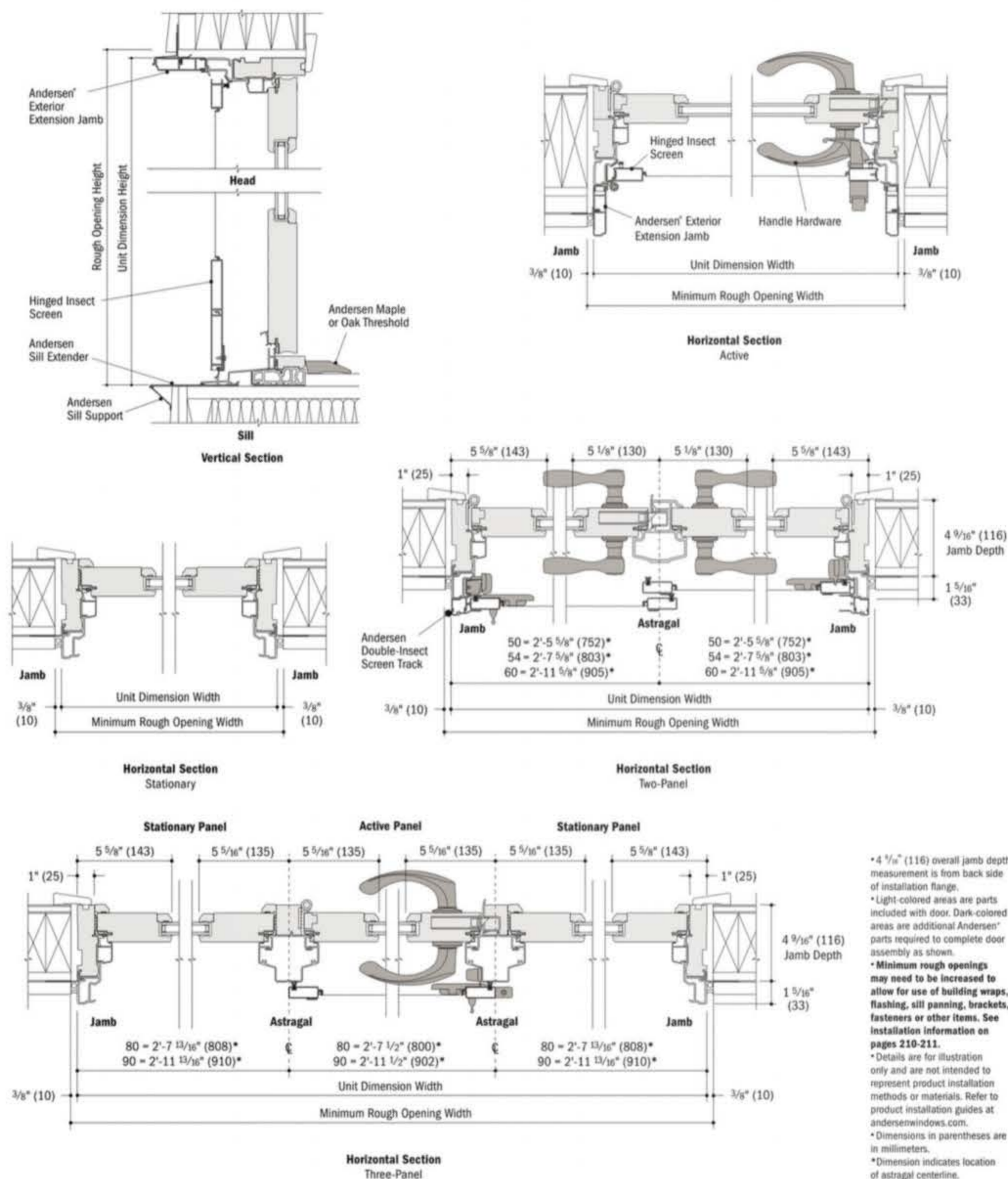

• 4 9/16" (116) overall jamb depth measurement is from back side of installation flange.  
 • Light-colored areas are parts included with door. Dark-colored areas are additional Andersen® parts required to complete door assembly as shown.  
 • Minimum rough openings may need to be increased to allow for use of building wraps, flashing, sill panning, brackets, fasteners or other items. See installation information on pages 210-211.  
 • Details are for illustration only and are not intended to represent product installation methods or materials. Refer to product installation guides at andersenwindows.com.  
 • Dimensions in parentheses are in millimeters.  
 • \*Dimension indicates location of astragal centerline.

## Clear Opening Details

Scale 1 1/2" (38) = 1'-0" (305) – 1:8

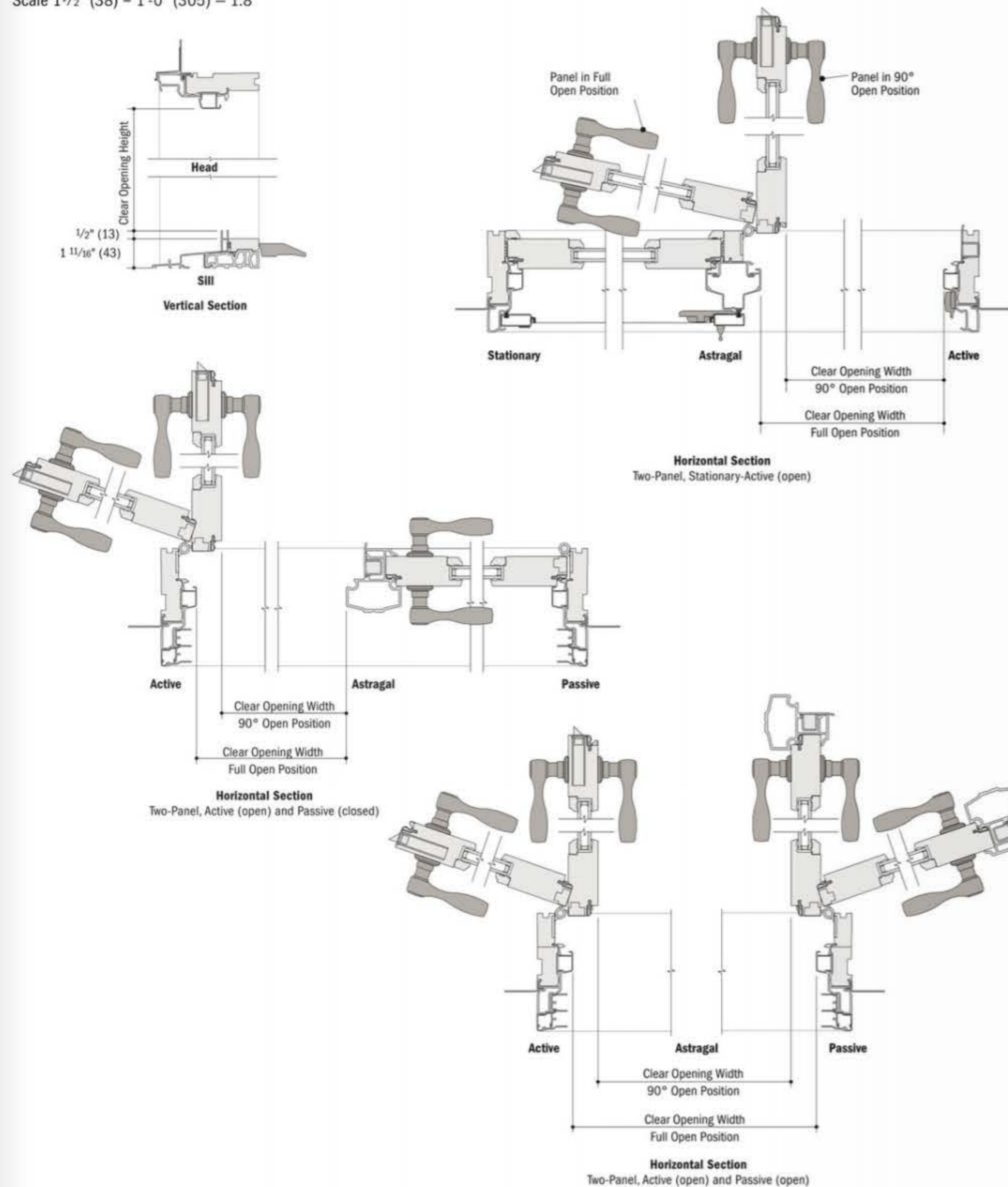

• Light-colored areas are parts included with door. Dark-colored areas are additional Andersen® parts required to complete door assembly as shown.  
 • Minimum rough openings may need to be increased to allow for use of building wraps, flashing, sill panning, brackets, fasteners or other items. See installation information on pages 210-211.  
 • Details are for illustration only and are not intended to represent product installation methods or materials. Refer to product installation guides at andersenwindows.com.  
 • Dimensions in parentheses are in millimeters.

# FRENCHWOOD® HINGED INSWING PATIO DOORS

## Ramped Sill Detail

Scale 1 1/2" (38) = 1'-0" (305) – 1:8

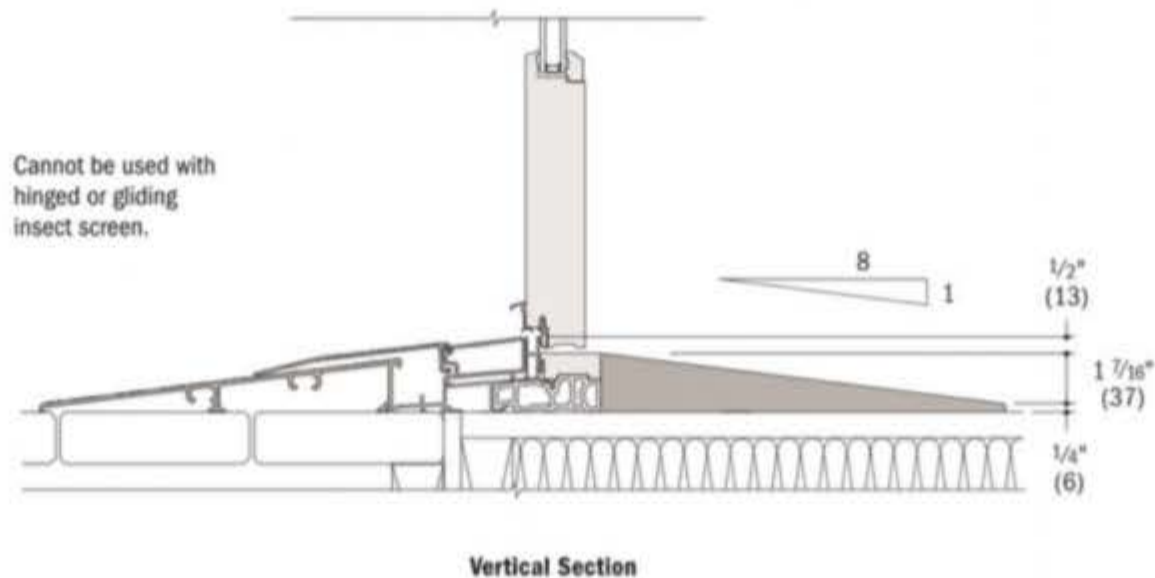

## Vertical Joining Detail

Scale 1 1/2" (38) = 1'-0" (305) – 1:8

### Overall Door Dimension Width

Sum of individual door widths plus 3/16" (5) for each join.

### Overall Rough Opening Width

Overall door dimension width plus 3/4" (19).

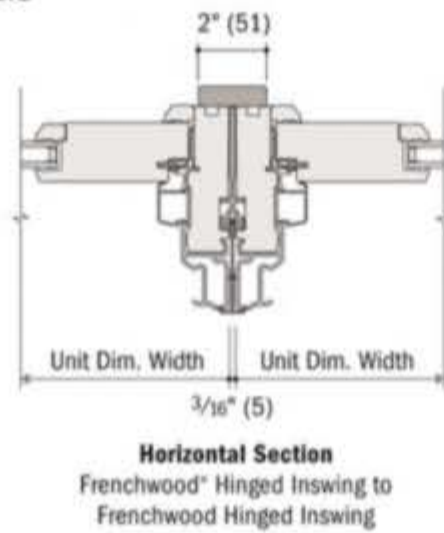

## Vertical Joining Detail – Fiberglass

Scale 1 1/2" (38) = 1'-0" (305) – 1:8

### Overall Door Dimension Width

Sum of individual door widths plus 3/4" (19) for each join.

### Overall Rough Opening Width

Overall door dimension width plus 3/4" (19).

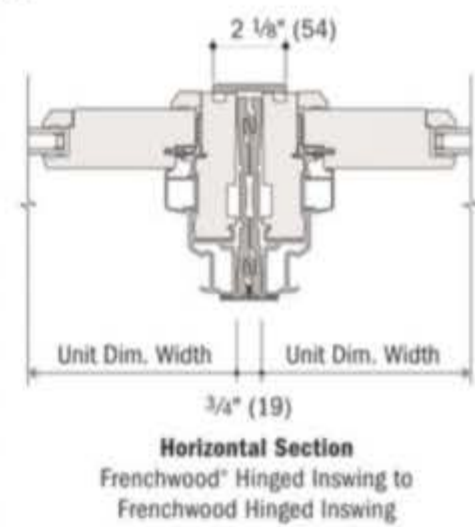

Andersen does not recommend joining of hinge jamb to hinge jamb.

For more joining information, see the combination designs section starting on page 181.

## Separate Rough Openings Detail

Scale 1 1/2" (38) = 1'-0" (305) – 1:8

To meet structural requirements or to achieve a wider joined appearance, doors may be installed into separate rough openings having vertical support (by others) in combination with Andersen® exterior filler and exterior vinyl trim.

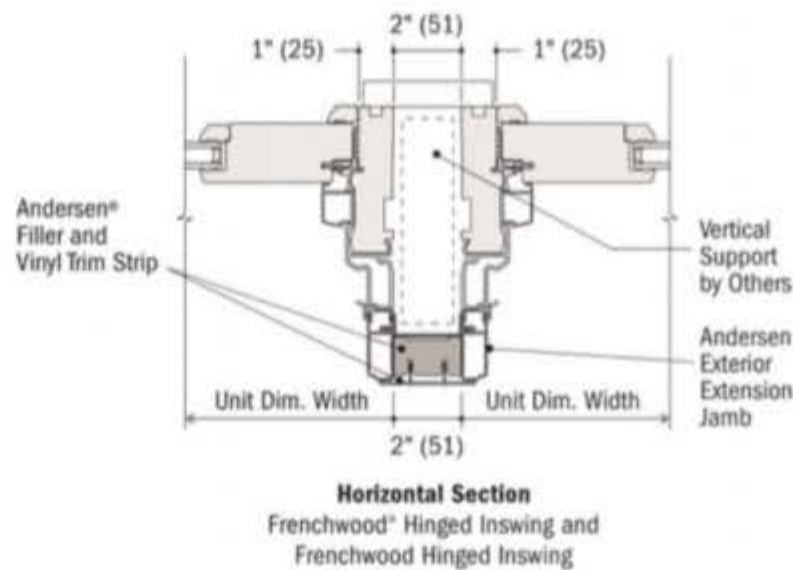

\* Light-colored areas are parts included with door. Dark-colored areas are additional Andersen® parts required to complete door assembly as shown.

\* Minimum rough openings may need to be increased to allow for use of building wraps, flashing, sill panning, brackets, fasteners or other items. See installation information on page 210-211.

\* Details are for illustration only and are not intended to represent product installation methods or materials. Refer to product installation guides at andersenwindows.com.

\* Andersen recommends installation of doors into separate rough openings. Consult with an architect or structural engineer regarding minimum requirements for structural support members between adjacent rough openings.

\* Dimensions in parentheses are in millimeters.



# WOODWRIGHT® DOUBLE-HUNG FULL-FRAME WINDOWS

- Tables of Sizes ..... 50-56
- Specifications ..... 54-61
- Custom Sizes ..... 62
- Grille Patterns ..... 63
- Window Details ..... 63-64
- Joining Details ..... 65
- Combination Designs ..... 181
- Product Performance ..... 197

**CUSTOM SIZING**  
in 1/8" (3) increments 

Dimensions in parentheses are in millimeters.

# WOODWRIGHT® DOUBLE-HUNG FULL-FRAME WINDOWS



## 400 SERIES

### FEATURES

#### FRAME

**A** Perma-Shield® exterior cladding protects the frame – beautifully. Best of all, it's low maintenance and never needs painting.\*

**B** For exceptional long-lasting performance, sill members are constructed with a wood core and a Fibrex® material exterior.

**C** Natural wood stops are available in pine, maple, oak and prefinished white. Wood jamb liners add beauty and authenticity to the window interior.

**D** A factory-applied rigid vinyl flange on the head, sill and sides of the outer frame helps secure the unit to the structure.

**E** Multiple weatherstrip systems help provide a barrier against wind, rain and dust. The combination of spring-tension vinyl, rigid vinyl and flexible bulb weatherstrip is efficient and effective.

**F** For units with white exterior color, the exterior jamb liner is white. For all other units, the exterior jamb liner is gray.

#### SASH

**G** Balancers in the sash enable contractors to screw through the jamb during installation without interfering with the window's operation.

#### Wood Jamb Liner

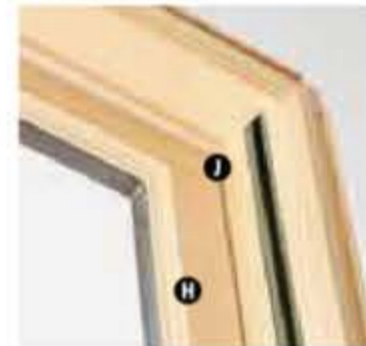

**H** Natural wood sash interior with classic chamfer detailing. Available in pine, maple, oak or prefinished white.

**I** Low-maintenance sash exterior provides long-lasting protection and performance. Sash exteriors on most units include Fibrex material.

**J** Sash joints simulate the look of traditional mortise-and-tenon construction inside and out.

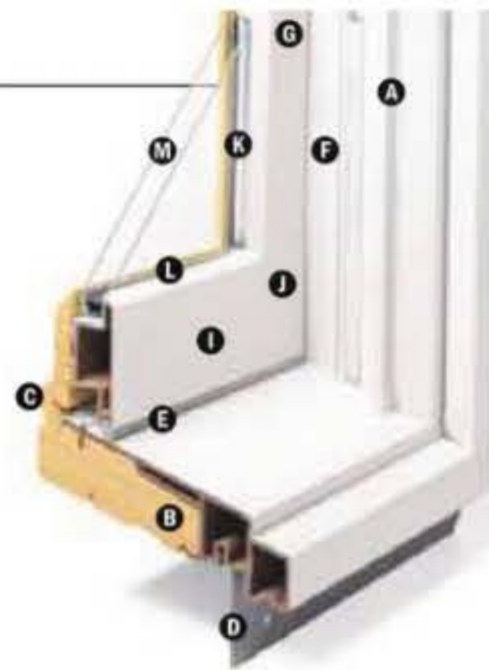

#### GLASS

**K** In addition to stainless steel glass spacers, black or white glass spacers are now available to allow the spacer to blend in with the unit color.

**L** Silicone bed glazing provides superior weathertightness and durability.

**M** High-Performance options include:

- Low-E4® glass
- Low-E4 HeatLock® glass
- Low-E4 SmartSun™ glass
- Low-E4 SmartSun HeatLock glass
- Low-E4 Sun glass

Tempered and other glass options are available. Contact your Andersen supplier.

A removable translucent film helps shield the glass from damage during delivery and construction, and simplifies finishing at the job site.

#### Patterned Glass

Patterned glass options are available. See page 12 for more details.

#### HARDWARE



Standard lock and keeper design provides an easy tilt-to-clean feature integrated into the lock.

### EXTERIOR & INTERIOR OPTIONS

#### EXTERIOR COLORS



#### INTERIOR OPTIONS



### HARDWARE



Standard Lock & Keeper

Antique Brass | **Black** | Bright Brass  
Brushed Chrome | Distressed Bronze  
Distressed Nickel | Gold Dust  
Oil Rubbed Bronze | Polished Chrome  
Satin Nickel | Stone | White

### OPTIONAL HARDWARE Sold Separately

#### CONTEMPORARY



Bar Lift

Available in all hardware finishes. Shown in **Distressed Nickel**.

#### ESTATE™



Hand Lift | Finger Lifts

Antique Brass | Bright Brass  
Brushed Chrome | Distressed Bronze  
Distressed Nickel | Oil Rubbed Bronze  
Polished Chrome | **Satin Nickel**

#### TRADITIONAL



Bar Lift | Hand Lift | Finger Lifts

Antique Brass | Black | Bright Brass | Brushed Chrome  
Distressed Bronze | Distressed Nickel | Gold Dust | **Oil Rubbed Bronze**  
Polished Chrome | Satin Nickel | Stone | White

#### CLASSIC SERIES™



Bar Lift | Hand Lift | Finger Lifts

Stone | **White**

Bold name denotes finish shown.

### HARDWARE FINISHES



\*Visit [andersenwindows.com/warranty](http://andersenwindows.com/warranty) for details.

Dimensions in parentheses are in millimeters.

Printing limitations prevent exact replication of colors and finishes. See your Andersen supplier for actual color and finish samples.

Naturally occurring variations in grain, color and texture of wood make each window one of a kind. All wood interiors are unfinished unless a finish is specified.

Distressed bronze and oil rubbed bronze are "living" finishes that will change with time and use.

### StormWATCH PROTECTION

#### Performance Grade (PG) Upgrades

Performance upgrades are available for select sizes of standard, non-impact Woodwright® windows allowing these units to achieve higher performance ratings.

Performance Grade (PG) ratings are more comprehensive than Design Pressure (DP) ratings for measuring product performance. For up-to-date performance information of individual products, visit [andersenwindows.com](http://andersenwindows.com). Use of this option will subtract 3/8" (16) from clear opening height. Contact your Andersen supplier for availability.

Visit [andersenwindows.com/coastal](http://andersenwindows.com/coastal) for more information on Stormwatch® Protection.

#### SHAPES

Woodwright windows are available in the following shapes.



Double-Hung | Springline™ Single-Hung



Arch Double-Hung | Unequal Leg Arch Double-Hung

#### SASH OPTIONS\*



Cottage | Reverse Cottage

\*Shown on 400 Series tilt-wash double-hung windows.

\*\*Do not add combination units to windows with Low-E4 Sun glass unless window glass is tempered. Combination units may also reduce the overall clear operable area of the window. See your local code official for egress requirements in your area.

†TruScene insect screens let in over 25% more fresh air than standard Andersen fiberglass insect screens.

Dimensions in parentheses are in millimeters.

### ACCESSORIES Sold Separately

#### FRAME

##### Extension Jamb



Standard jamb depth is 4 1/2" (114). Extension jambs are available in unfinished pine or prefinished white. Some sizes may be veneered.

Factory-applied and non-applied interior extension jambs are available in 1/16" (1.5) increments between 5 1/4" (133) and 7 1/8" (181). Extension jambs can be factory applied to either three sides (stool and apron application) or four sides (picture frame casing).

##### Pine Stool



A clear pine stool is available and ready for finishing. The Woodwright stool is available in 4 9/16" (116) for use in wall depths up to 5 1/4" (133) and 6 9/16" (167) for use in wall depths up to 7 1/8" (181). Works with 2 1/4" (57) and 2 1/2" (64) casing widths. Shown above on a 400 Series tilt-wash double-hung window.

#### HARDWARE

##### Window Opening Control Device



A window opening control device is available, which limits sash travel to less than 4" (102) when the window is first opened. Available factory applied, or as a field-applied kit in stone or white.

##### STORM/INSECT SCREEN COMBINATION UNIT\*\*



A self-storing storm window combined with an insect screen provides greater energy efficiency, while allowing ventilation when needed.

Constructed with an aluminum frame, single-pane upper and lower glass panels, and charcoal powder-coated aluminum screen mesh. Available in white, Sandtone and Terratone to match product exteriors. Canvas, dark bronze, forest green and black are available by special order.

Combination units can improve Sound Transmission Class (STC) and Outdoor Indoor Transmission Class (OITC) ratings. Ideal for projects near airports, busy roadways or other noisy environments. For example, adding a combination unit to a 400 Series tilt-wash double-hung (3862) unit with Low-E4® glass will improve its STC rating from 26 to 32. Contact your Andersen supplier for additional STC and OITC rating information.

#### INSECT SCREENS

##### Insect Screen Frames



Choose full insect screen or half insect screen. Half insect screen (shown above) allows ventilation without affecting the view through the upper sash. Frames are available in colors to match product exteriors.

##### TruScene® Insect Screens

Andersen TruScene insect screens let in over 25% more fresh air† and provide 50% greater clarity than conventional Andersen insect screens, all while keeping out unwanted small insects.

##### Conventional Insect Screens

Conventional insect screens have charcoal powder-coated aluminum screen mesh.

#### GRILLES

Grilles are available in a variety of configurations and widths. For double-hung grille patterns, see page 63.

#### EXTERIOR TRIM

Available with Andersen® exterior trim. See exterior trim section starting on page 175.

#### CAUTION:

- Painting and staining may cause damage to rigid vinyl.
- 400 Series windows in Terratone color may be painted any color lighter than Terratone color using quality oil-based or latex paint.
- Do not paint 400 Series windows with white, canvas, Sandtone, dark bronze, forest green or black exterior colors.
- Andersen does not warrant the adhesion or performance of homeowner-applied paint over vinyl or other factory-coated surfaces.
- For vinyl painting instructions and preparation, contact your Andersen supplier.
- Do not paint weatherstrip.
- Creosote-based stains should not come in contact with Andersen products.
- Abrasive cleaners or solutions containing corrosive solvents should not be used on Andersen products.

# WOODWRIGHT® DOUBLE-HUNG FULL-FRAME WINDOWS



## 400 SERIES

### Woodwright® Double-Hung Window Details

Scale 1 1/2" (38) = 1'-0" (305) – 1:8

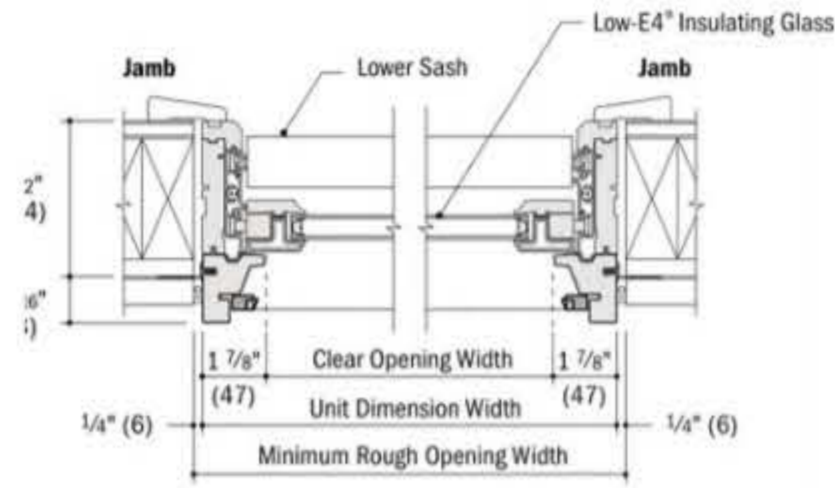

Horizontal Section

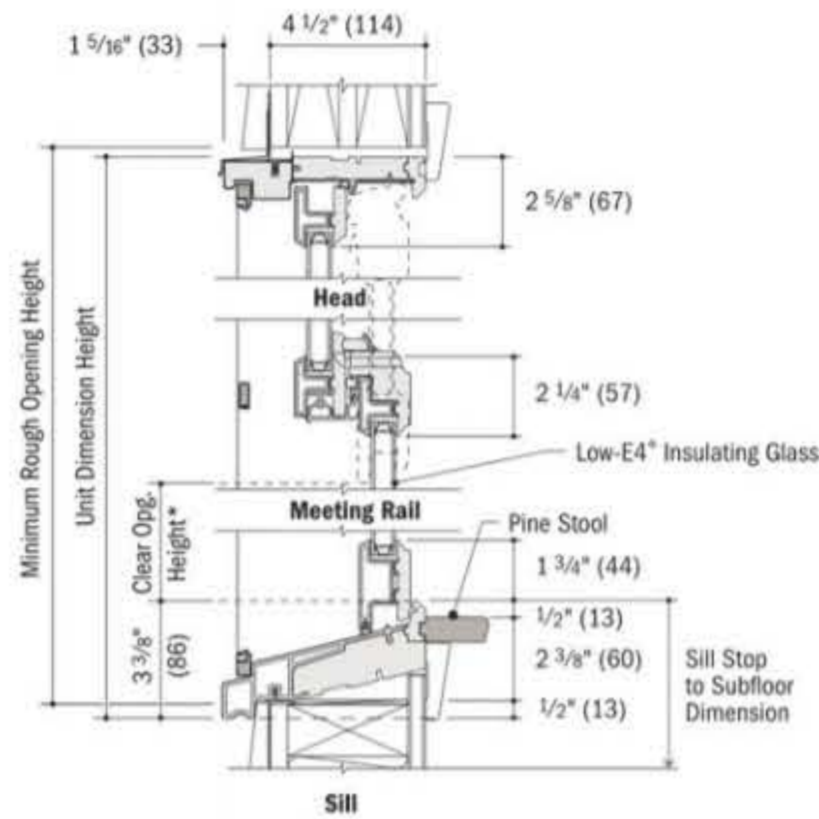

Vertical Section

### Woodwright® Picture Window Details

Scale 1 1/2" (38) = 1'-0" (305) – 1:8

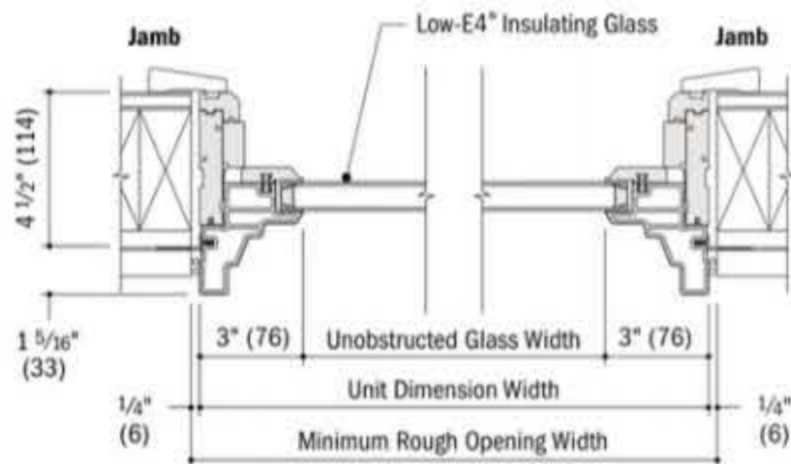

Horizontal Section

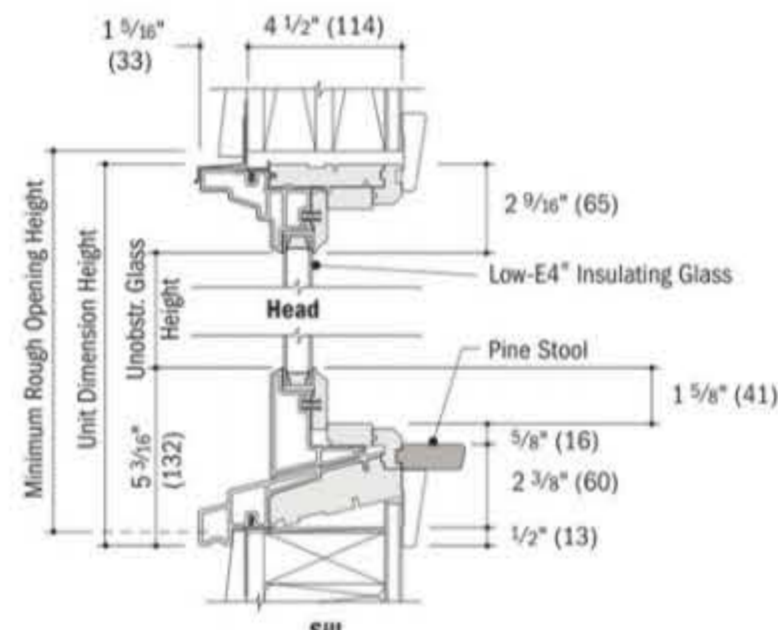

Vertical Section

### Horizontal (stack) Joining Detail

Scale 1 1/2" (38) = 1'-0" (305) – 1:8

#### Overall Window Dimension Height

Sum of individual window heights plus 1/16" (1.5) for each join.

#### Overall Rough Opening Height

Overall window dimension height.\*

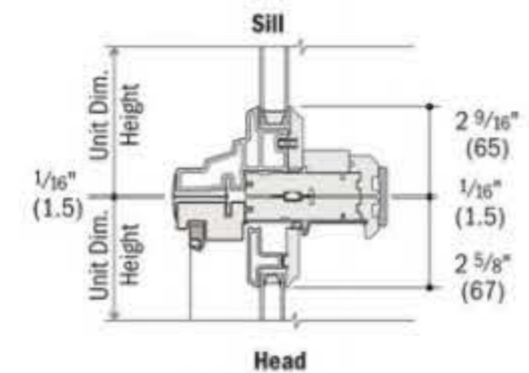

Woodwright® Transom (WTR) over Woodwright Double-Hung

### Vertical (ribbon) Joining Detail

Scale 1 1/2" (38) = 1'-0" (305) – 1:8

#### Overall Window Dimension Width

Sum of individual window widths plus 1/16" (1.5) for each join.

#### Overall Rough Opening Width

Overall window dimension width plus 1/2" (13).

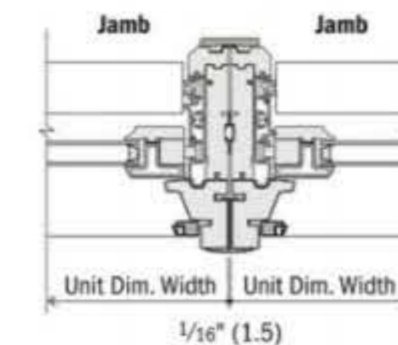

Woodwright® Double-Hung to Woodwright Double-Hung

For more joining information, see the combination designs section starting on page 181.

### Separate Rough Openings Detail

Scale 1 1/2" (38) = 1'-0" (305) – 1:8

To meet structural requirements or to achieve a wider joined appearance, windows may be installed into separate rough openings having vertical support (by others) in combination with Andersen® exterior filler and exterior vinyl trim.

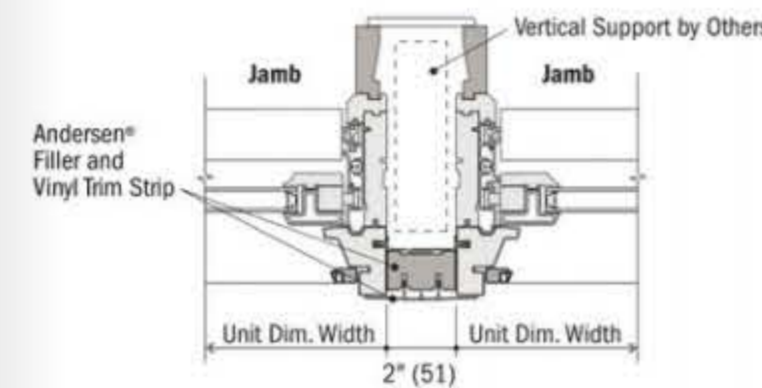

Woodwright® Double-Hung and Woodwright Double-Hung

\*Light-colored areas are parts included with window. Dark-colored areas are additional Andersen® parts required to complete window assembly as shown.  
 • Minimum rough openings may need to be increased to allow for use of building wraps, flashing, sill panning, brackets, fasteners or other items. See installation information on pages 210-211.  
 • Details are for illustration only and are not intended to represent product installation methods or materials. Refer to product installation guides at andersenwindows.com.  
 • Dimensions in parentheses are in millimeters.  
 • Clear opening height dimension is less on arch, unequal leg arch and Springline® hung windows.

\*Light-colored areas are parts included with window. Dark-colored areas are additional Andersen® parts required to complete window assembly as shown.  
 • Minimum rough openings may need to be increased to allow for use of building wraps, flashing, sill panning, brackets, fasteners or other items. See installation information on pages 210-211.  
 • Details are for illustration only and are not intended to represent product installation methods or materials. Refer to product installation guides at andersenwindows.com.  
 • Consult with an architect or structural engineer regarding minimum requirements for structural support members between adjacent rough openings.  
 • Dimensions in parentheses are in millimeters.  
 • For stacks where bottom unit in combination is a double-hung or picture window with a sloped sill. If bottom window has a flat sill, add 1/2" (13) to the overall window dimension height.

**Dear Detroit Historic District Commission,**

My name is Thomas Typinski, and I am one of the owners of 708 Pallister St. I am writing to provide an overview of the progress and challenges encountered during this project, as well as to share my personal commitment to restoring this unique historic property.

In December 2023, my partner and I acquired the property at 708 Pallister. We understood from the start that restoring a historic home would be a complex endeavor. As a 100% permanently and totally disabled veteran living on a fixed income, as well as a Detroit native, I took on this project with the dual intention of supplementing my income and preserving a piece of Detroit's history by honoring the significance of this home.

Recognizing the complexity of rehabilitating a historic property, I hired Timothy Flintoff at 4545 Architecture to create a plan that adhered to the Detroit Historic District Commission's (HDC) guidelines. These plans were then handed over to Home City Properties, a contractor recommended to me by a close friend. I trusted their experience in the Detroit area, expecting them to follow the plans and respect the guidelines set forth by the HDC.

However, shortly after the project began, it became evident that Home City Properties was not adhering to the approved plans, starting with the construction of improperly sized dormers. They proceeded to make unauthorized changes, causing significant damage to the property in the process. For example, they demolished parts of the home in a manner that required additional tradespeople to repair, and they disposed of irreplaceable historic elements of the house despite being explicitly instructed on multiple occasions to preserve them. Additionally, they ordered and installed incorrect windows that deviated from the approved design, specifically missing the colonial grid and black exterior—both crucial to maintaining the historic character of the property.

In February 2024, the City of Detroit issued a stop-work order. We immediately halted all work and took the necessary steps to bring the project back into compliance. By late March, we had addressed the issues, and work resumed. Then, in June, we received a second stop-work order, which we later learned was mistakenly issued due to a missing permit in the window. Once this was resolved, work resumed again within a week. At both points, we believed the work completed was in compliance, as the city inspectors had lifted the stop-work orders, allowing us to proceed.

Despite these setbacks, it was never my intention to bypass the authority of the HDC or cut corners. I now understand that nothing should have been done outside of the approved plans and am working with Timothy Flintoff and his team to provide you with an application that includes every last detail. After replacing Home City Properties with a new contractor, we have made substantial progress in remedying the issues caused by the previous contractor and are committed to ensuring the project is completed correctly and in accordance with all guidelines.

I would also like to emphasize that during both stop-work orders, we made every effort to comply with city requirements and acted in good faith to address all concerns. We hope you will

take this into consideration when addressing the improperly sized dormers and window replacement, as further alterations to these elements would be catastrophic to the completion of this project.

Thank you for your thoughtful consideration when reviewing our application. We remain fully dedicated to restoring 708 Pallister in a way that honors its historic value and enriches the Pallister Park community. We are eager to complete this long-overdue rehabilitation and appreciate your guidance in bringing this project to a successful conclusion.

Sincerely,  
Thomas Typinski





October 21, 2024

708 Pallister St.,  
Detroit, MI 48202

RE: 708 Pallister Exterior Renovations, District Historic Commission Submission

### Scope of Work

1. Repair and/or replace existing wood siding, detailing, and soffits where required
  - a. Where replacement is required, in-kind materials are to be used
2. All wood elements are to be painted in accordance with appropriate Detroit Historic Commission Color System F
3. Repair and paint existing dormer window
4. Replace existing windows with Fibrex-clad wood windows (Anderson 400 Series)
  - a. Simulated divided lites to be added
5. Repair masonry front porch
  - a. Add brick veneer, paint to match existing
6. Replace damaged front masonry stair
7. Add new precast front masonry stair
8. Install new wood handrail at masonry front porch. Paint to match window trim.
9. Install new 4x4 wood support columns on existing front porch
  - a. Wrap support posts in pine to 12x12, paint to match window trim
10. Infill basement entry door
  - a. Contractor is to use brick that matches existing
11. Infill rear entry door
  - a. Where exterior siding is to be placed, in-kind materials are to be used
12. Demolish existing rear deck and stair
13. Construct new wood rear deck and stair
14. Remove (2) rear windows, replace with hinged french door
  - a. Anderson 400 series hinged patio door to be used; door frame color to coordinate with painted existing windows
15. Remove (2) rear windows
  - a. Replace with (1) gliding Fibrex-clad wood window (Anderson 400 Series)
  - b. Infill as required using in-kind materials

# 4545 architecture

16. At East elevation, replace (1) window with gliding window (Anderson 400 Series)
17. At East elevation, remove (1) existing window, add (1) new window
18. Demolish chimney
19. Construct (3) new dormers
  - a. Dormer siding and roofing material and color to coordinate with existing structure
  - b. Dormer windows Anderson 400 series gliding type; window color to coordinate with painted existing windows