



Artisan Renovations LLC

Historic • Restoration • Solutions

www.artisan-renovationsllc.com

7810 Kercheval Ave

Window Restoration Assessment



Artisan Renovations LLC

Historic • Restoration • Solutions

www.artisan-renovationsllc.com

RIGHT ELEVATION (Seyburn St)

- Unit NN sash is missing. Replica sash will need to be fabricated to match proposed unit OO (full lite casement)
- Existing 10-Lite casement to be removed and new 1/1 double hung to be fabricated with profiles that exactly match existing double hungs in new proposed larger opening (Unit HH)
- "Curved in plan" sash in lower level (B, C, D) have decorative exterior grill. See photo. These grills are too corroded for restoration and should be removed and recycled.
- ALL other units on this elevation (frames and sash) to be fully restored

FRONT ELEVATION (Kercheval Ave)

- Fabricate new exact replica sash for NN and OO (full lite fixed)
- ALL other units on this elevation (frames and sash) to be fully restored

BACK ELEVATION

- Fabricate new exact replica sash for TT and UU (full lite fixed)
- ALL other units that remain on this elevation (frames and sash) to be fully restored

LEFT ELEVATION

- Fabricate new exact replica sash for RR and SS (full lite fixed)
- ALL other units on this elevation (frames and sash) to be fully restored



Artisan Renovations LLC

Historic • Restoration • Solutions

www.artisan-renovationsllc.com

LOWER LEVEL "AWNING"
"FULL RESTORE"
SASH

AWNING
SASH.
w/ CLEAR GLASS
EXISTING

TYP.
BRICKMOLD

EXISTING
"EYE HOOK"

3/4"
BOTTOM RAIL

WINDOW SCHEDULE

- # A
- # F
- # G
- # H

13 1/4"

← WINDOW SILL

EXISTING
"INTERIOR"
MASONRY
WALL

EXISTING
MASONRY
SILL

Project 7810 KERCHEVAL Date 25 SEPT. 2023 Signature [Signature]

Artisan Renovations LLC • 5923 Lake George Rd. Dryden, MI 48428 • 248.794.5095

tc.artisanrenovations@gmail.com

pg 1.



Artisan Renovations LLC

Historic • Restoration • Solutions

www.artisan-renovationsllc.com

EXISTING MEETING RAIL
(WILL BE RESTORED)

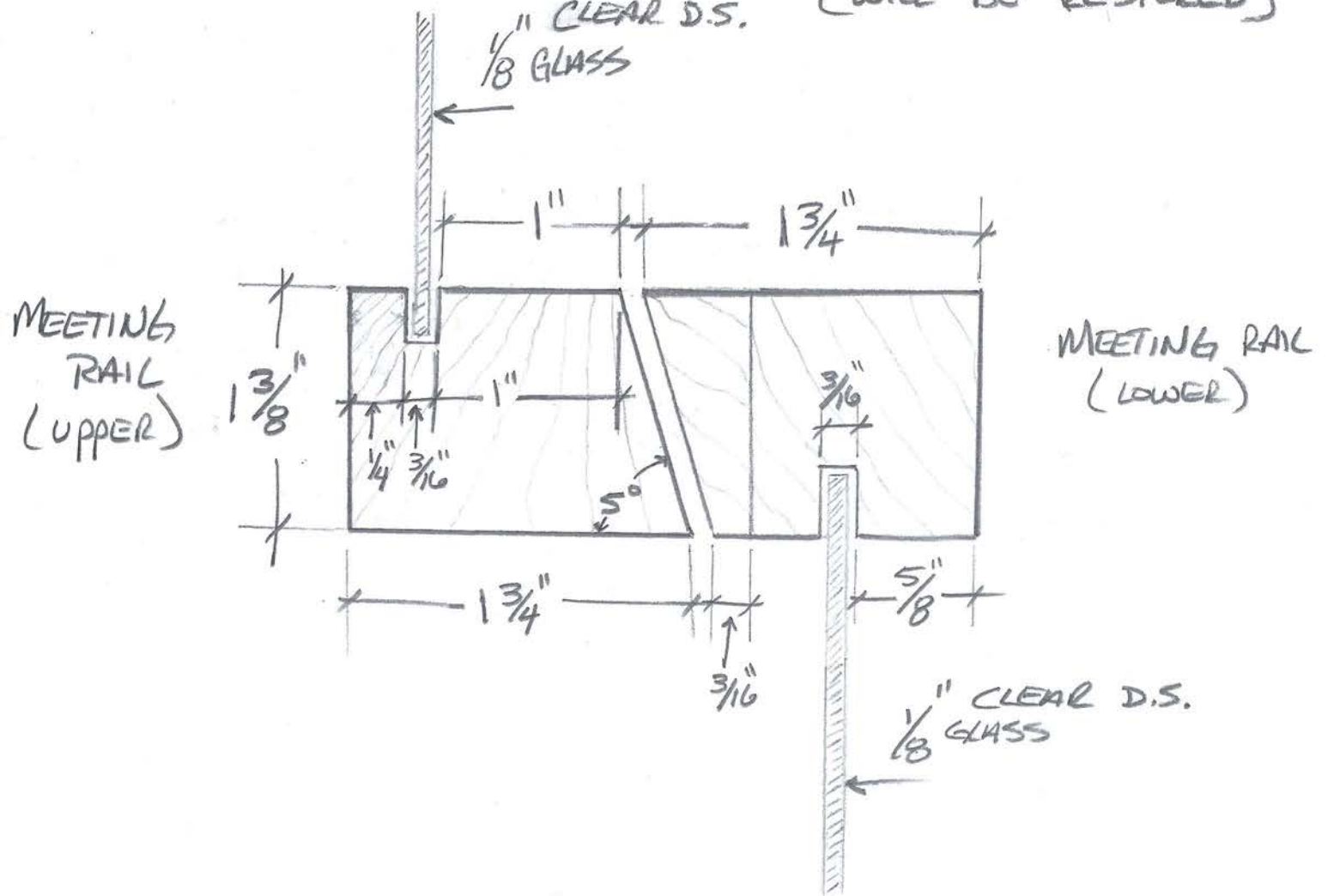

Project 7810 KERCHEVAL Date 10 SEPT. 2023 Signature [Signature]

Artisan Renovations LLC • 5923 Lake George Rd. Dryden, MI 48428 • 248.794.5095

tc.artisanrenovations@gmail.com



Artisan Renovations LLC

Historic • Restoration • Solutions

www.artisan-renovationsllc.com

EXISTING BRICKMOLD (TYP.)

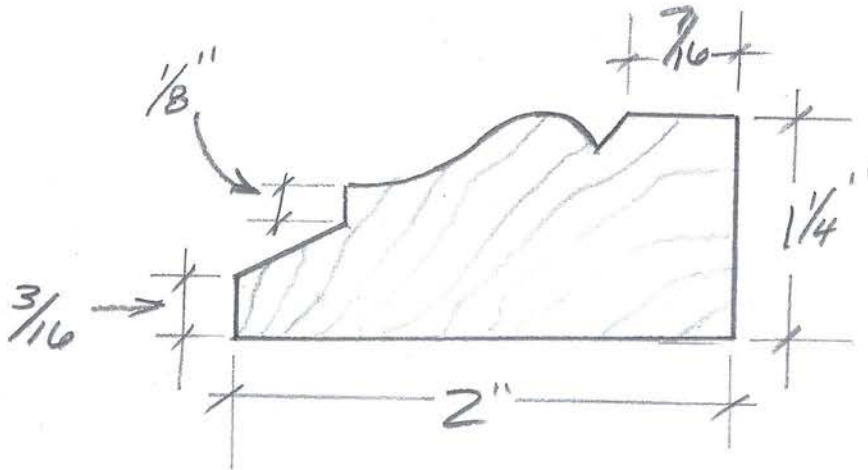

Project 7810 KERCHEVAL Date 20 SEPT. 2023 Signature [Signature]

Artisan Renovations LLC • 5923 Lake George Rd. Dryden, MI 48428 • 248.794.5095

tc.artisanrenovations@gmail.com



Artisan Renovations LLC

Historic • Restoration • Solutions

www.artisan-renovationsllc.com

EXISTING SILL & JAMB

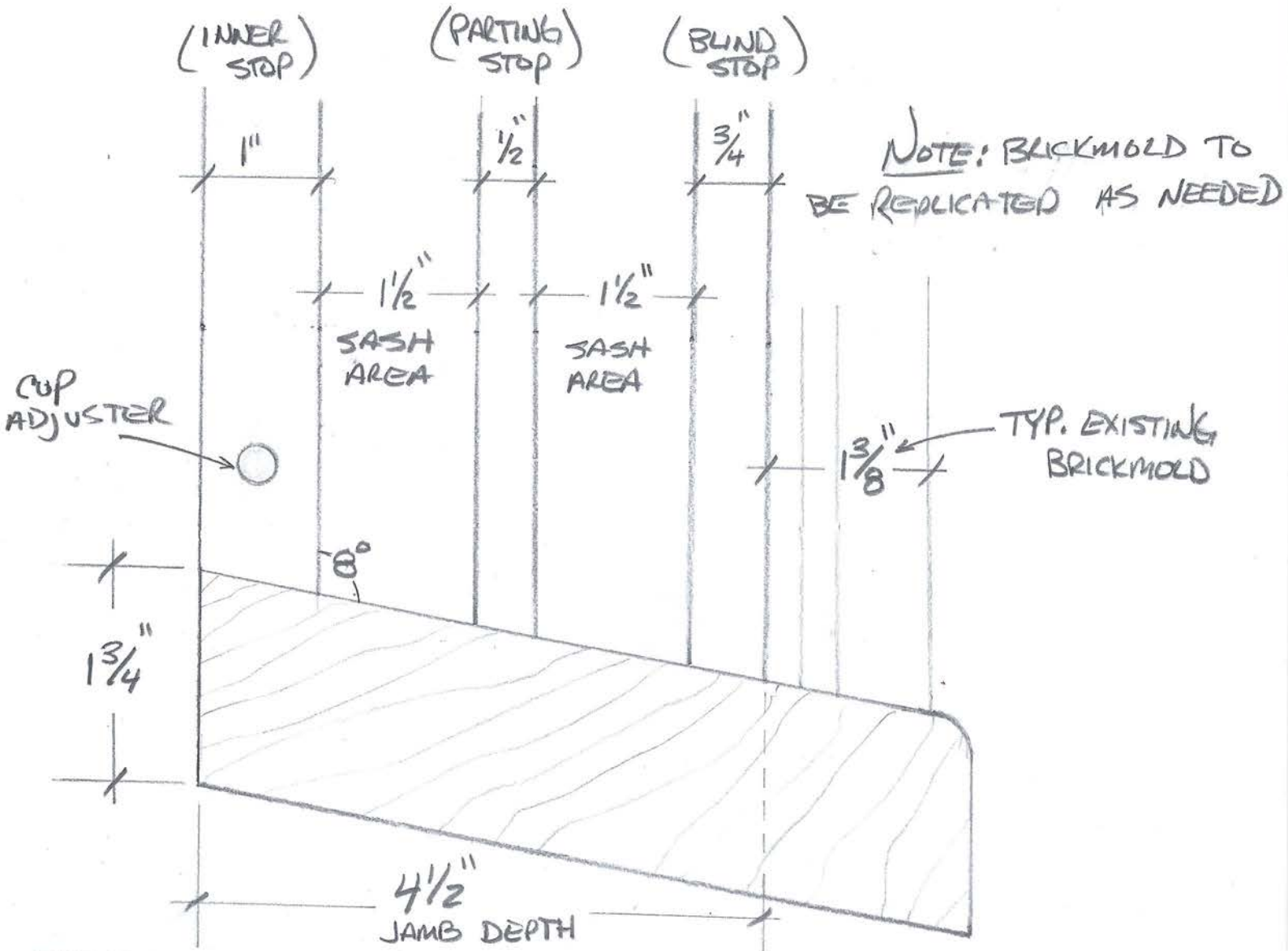

Project T810 KERCHEVAL Date 18 SEPT. 2023 Signature [Signature]

Artisan Renovations LLC • 5923 Lake George Rd. Dryden, MI 48428 • 248.794.5095

tc.artisanrenovations@gmail.com



Artisan Renovations LLC

Historic • Restoration • Solutions

www.artisan-renovationsllc.com

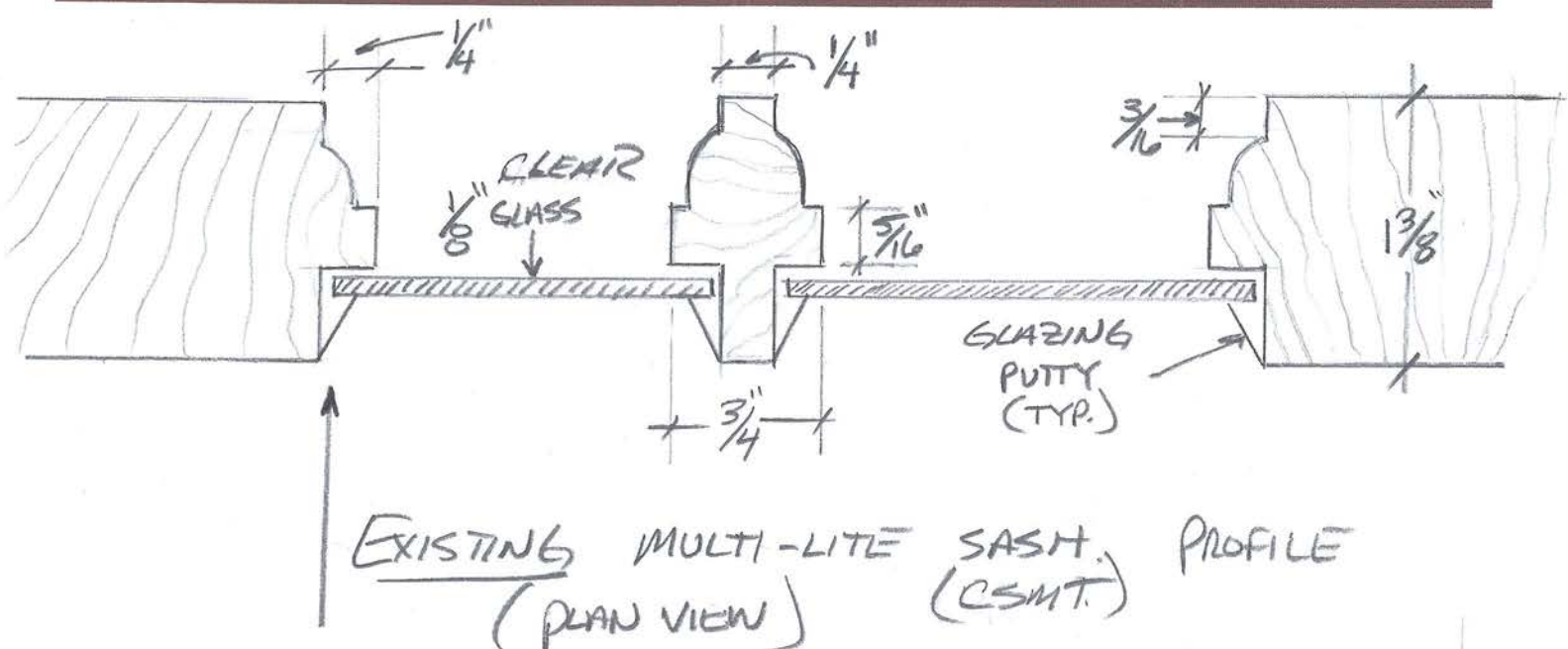

EXISTING MULTI-LITE SASH (PLAN VIEW) PROFILE

NOTE: UNIT TO BE 2X WIDER THAN EXISTING UNIT

PROPOSED 1/2 D.H. SASH (# HH) & FULL-LITE CSMT. SASH (# NN, # OO)

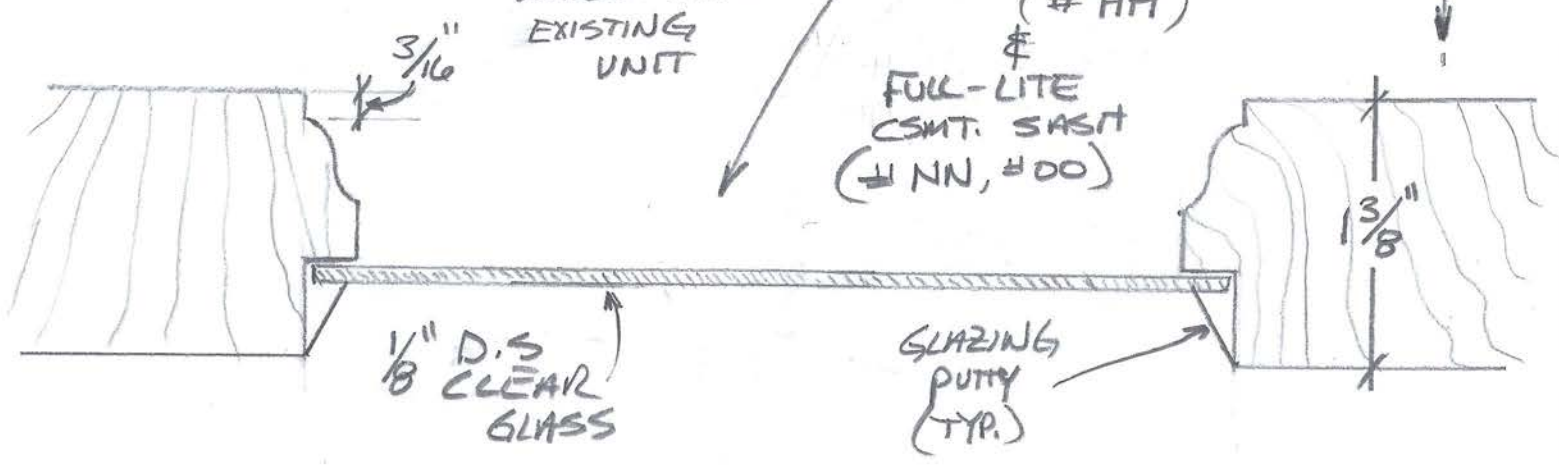

1/8" D.S. CLEAR GLASS

GLAZING PUTTY (TYP.)

Project TBID KERCHEVAL Date 18 SEPT. 2023 Signature [Signature]

Artisan Renovations LLC • 5923 Lake George Rd. Dryden, MI 48428 • 248.794.5095

tc.artisanrenovations@gmail.com

P.5



full unit
restoration
Pic #1



Pic #2
full restore

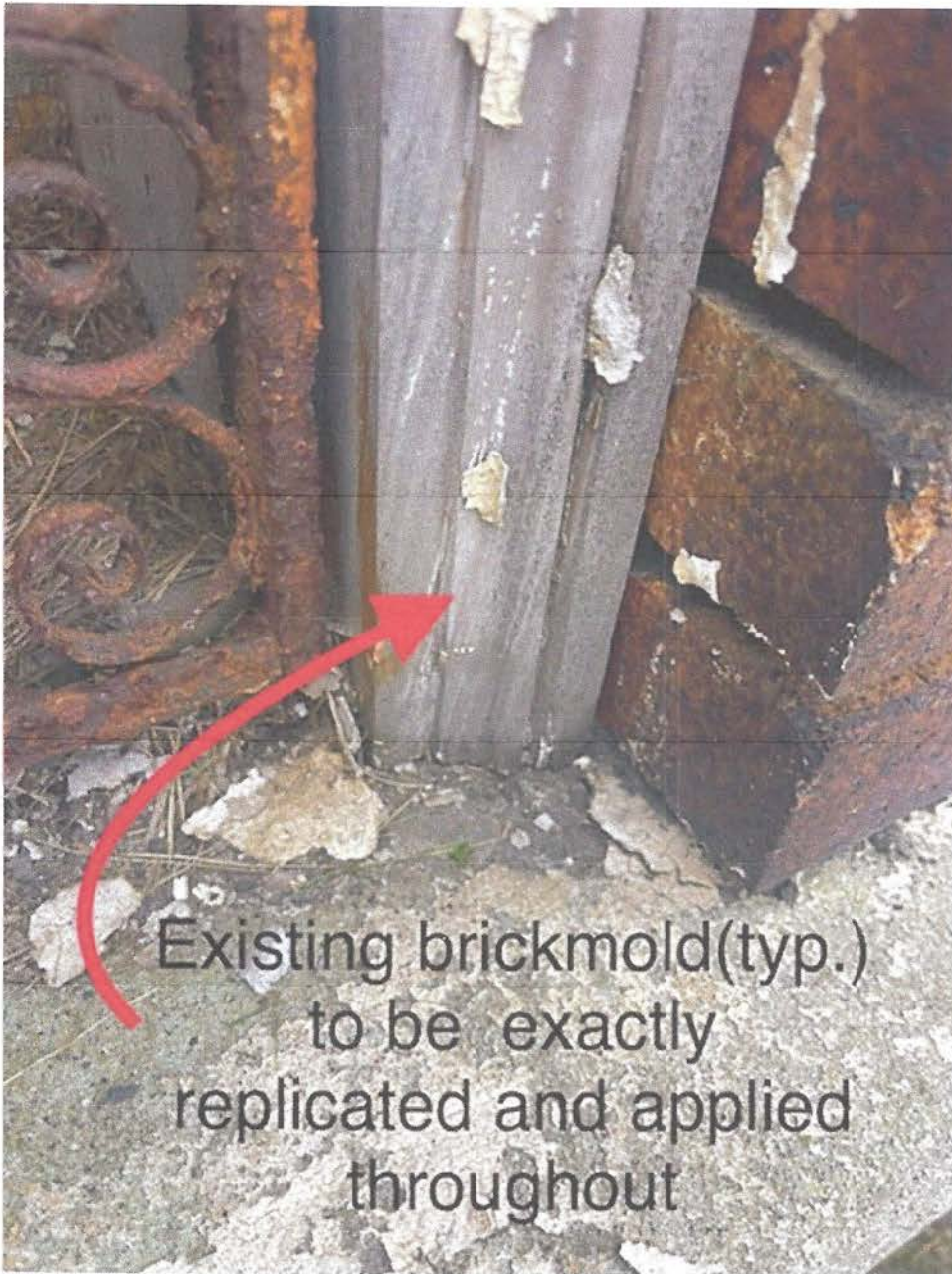

Existing brickmold(typ.)
to be exactly
replicated and applied
throughout

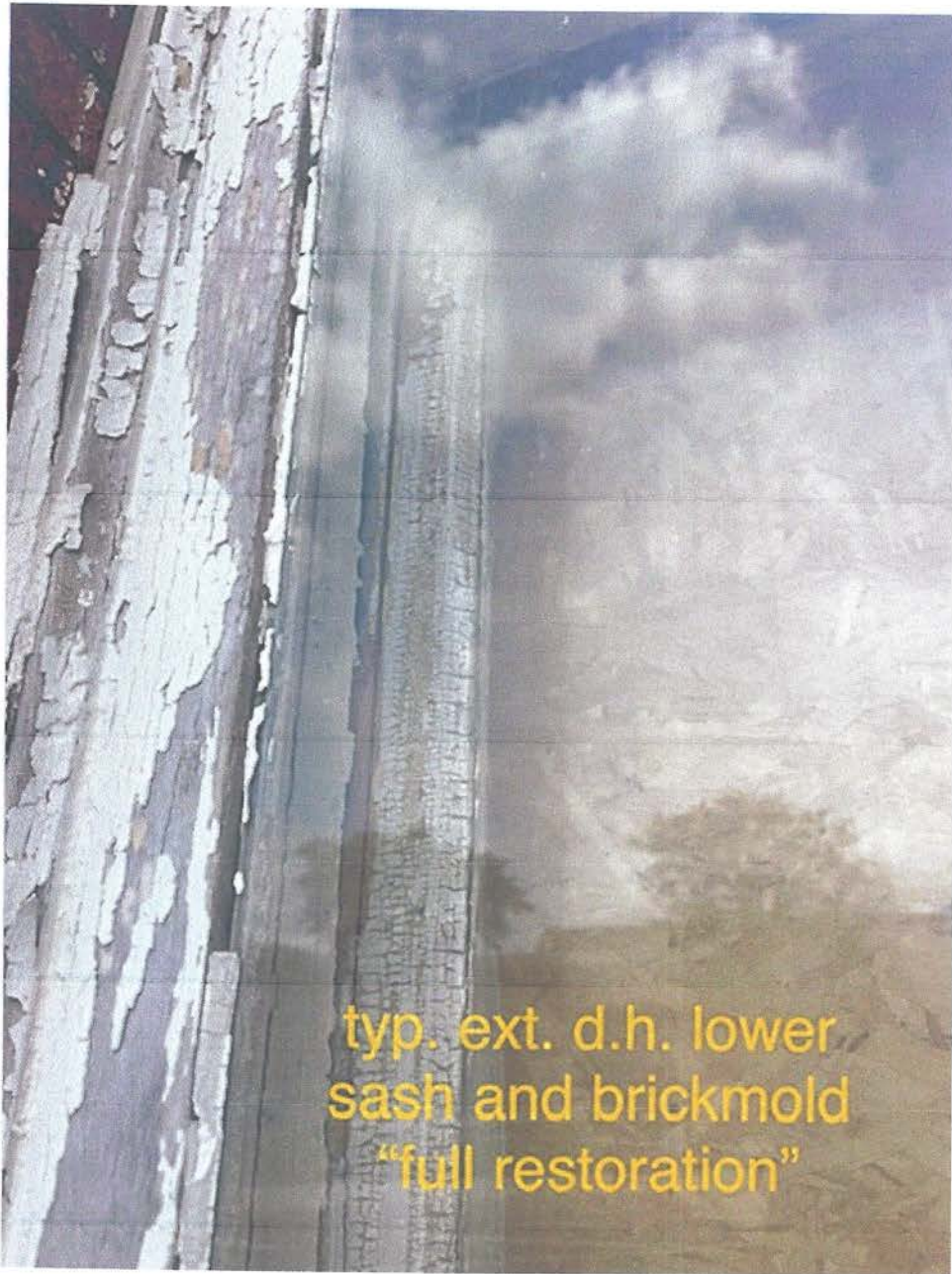

typ. ext. d.h. lower
sash and brickmold
"full restoration"