

Window Replacement Guide

INFINITY[®]

from MARVIN[®]

REPLACEMENT WINDOWS

Built for life[®]

Peace of mind —
before, during and
after installation.

Getting new windows for your home can seem like a stressful, confusing and daunting task. But it doesn't have to be that way. Infinity from Marvin focuses on streamlining your window replacement experience from start to finish — all to help you find the perfect new windows for your home. Because some decisions should only be made once.

Steps for replacing your windows:

01

Expert consultation

PAGE 03

02

Finding your perfect fit

PAGE 04

03

Seamless installation

PAGE 05

04

Built for Life[®]

PAGE 06

Window Replacement Glossary

PAGE 07

Connect with a local expert

The first step in the replacement process is a free, no-obligation consultation with your local Infinity independent partner to assess your windows to ensure they need to be replaced. They will answer all your questions and provide a detailed, custom project quote based on your specifications. Here are some key indicators that your home is a good candidate for new windows:



Moisture issues

If you've seen water between glass panes, leaking, water stains or evidence of wood rot – those are signs that excess moisture is accumulating where you can't see it. This can lead to damage, including mold, mildew and warping. While some condensation is normal, an excess of moisture often points to a problem.



Faulty operation

Older windows have a tendency to refuse to open or have a hard time closing. This is an early sign of problems to come. You may be able to fix the issue with cleaning or repairs but save yourself the headache and consider new windows.



Energy efficiency

Older windows can cause drafty rooms and uncomfortable temperatures inside your home. New energy-efficient Infinity windows can help make rooms more comfortable and save on energy costs.



Safety

Since windows are a key entry point to your home, broken windows are a major issue and should be addressed immediately. Replacing broken windows is also important to help keep kids and pets safe.



Get expert guidance

Depending on the age and style of your home, Infinity offers two window replacement methods. Your local Infinity partner will help you determine the best solution for your home, including addressing any concerns about water or structural damage. Both methods are designed for maximum efficiency and minimal disruption to your home.

Insert replacement

With insert window replacement, new windows are easily installed into the existing frame. This is generally a quicker replacement solution because the existing trim and siding are not replaced.

Full-frame replacement

Full-frame replacement requires taking out the existing damaged frame and trim. This window installation method offers the possibility of replacing your existing window with an entirely new style or larger window.



DOUBLE AND SINGLE HUNG



SLIDER



CASEMENT



AWNING

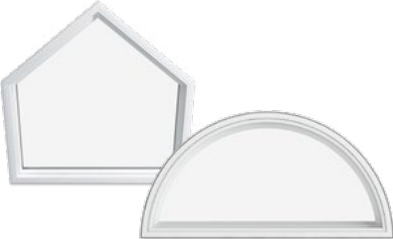

SPECIALTY SHAPES AND ROUND TOPS



BAY



BOW

How window installation happens



Prep for installation

Plan to know who will be home when the installation team arrives and how to keep children and pets safe and sound. Be sure to clear access to both the interior and exterior sides of the window and disarm any alarms prior to installation. Your Infinity partner will inform you of their process prior to installation day to give you time to do an assessment of your curtains/blinds, furniture, rugs and other items that may need to be moved on installation day.

What to expect during installation

From floor coverings to dust containment, prep to clean-up, Infinity partners respect your indoor and outdoor living spaces and treat your home as if it were their own. Expect the crew to work respectfully and diligently to minimize disruption and install your new windows efficiently.

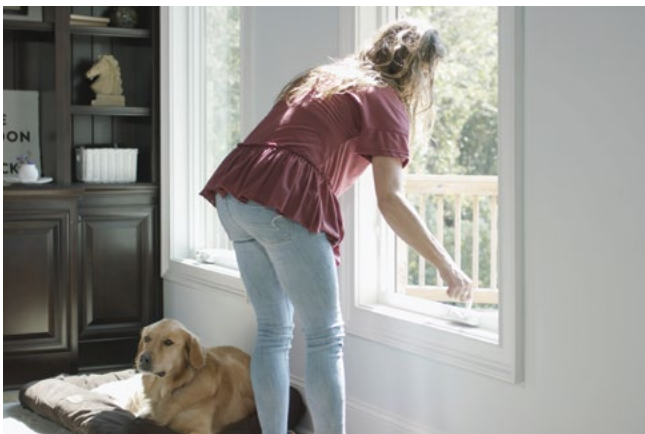

Post-installation

After your new windows are installed, your install crew will talk you through how to operate your Infinity windows.

Long-term peace of mind

From our Limited Lifetime Warranty to our partners' unparalleled customer service, we go above and beyond to ensure your windows always provide a lifetime of optimal performance.



Warranty

Life happens. That's why it's essential to examine the warranty on any replacement project before you complete your purchase.

Infinity from Marvin offers a Limited Lifetime Warranty to give you peace of mind. For full details on our Limited Lifetime Warranty, visit infinitywindows.com/warranty.



Customer service

It's perfectly normal to have questions long after your windows have been installed. When you have questions – whether about UV protection or window cleaning – you should get quick and clear answers. Infinity picks our local independent partners based on their customer-service experience, so you can be sure they'll be there when you need them.

Window Replacement Glossary

Assembly

Two or more units mullied (attached) together to create one larger grouping.

Awning

A top-hinged window that swings out from the bottom with crank-out hardware.

Bay

A series of windows installed in an angled “bay” formation with a head and seat board. Typically, two smaller operating units flank a larger fixed center window.

Bow

A series of adjoining window units that are configured in a gradual arc.

Casement

A side-hinged window that swings out from the left or right with crank-out hardware.

Check Rail

The horizontal portion of a double hung window where the top and bottom sash meet. Simulated check rails use divided lite bars to simulate the look of a double hung window in a casement or slider.

Condensation

Moisture that forms on a surface. This could be a result of a difference in temperature between the surface and the air, or high humidity in the home.

Daylight Opening (DLO)

The area of the window or door where light passes through; the width and the height of the visible glass.

Direct Glaze (Polygon)

Stationary or fixed window with no sash for maximum daylight opening. Glass is glazed directly into the frame.

Divided Lite / Simulated Divided Lite (SDL)

Decorative bars permanently adhered to glass (Simulated Divided Lites) or between two panes of glass (Grilles Between Glass) to add architectural interest on a window.

Double Hung

Double hung windows have two movable sash (top and bottom) which are hung in the window frame and slide/operate vertically.

Frame

The stationary portion of a window that surrounds either the glass (direct glaze) or the sash (operating or stationary). There are three components to the frame: the header across the top, the jambs down each side and the sill across the bottom.

Glazing

Installing glass into windows and doors.

Slider

Horizontal operating units which have one sash fixed while the other glides open left or right.

GBG's (Grilles Between the Glass)

Dividers placed between the panes of insulated glass to simulated authentic divided lites. GBGs allow for easier window cleaning with no bars on the exterior or interior surface of the glass.

Hardware

The locks, crank handles and hinges on windows and doors used to operate and secure them.

Head Jamb

The horizontal piece forming the top of the frame on a window or door.

Mull/Mulling

The actual components used to attach two or more windows and/or door units together to form an assembly. The process of attaching two or more window or door units together.

Muntins

Bars that form the decorative grille pattern on a window or door.

Operator

A moving sash, panel or unit.

Picture Window

A fixed/stationary window to align with the profiles of operating windows. Sash is non-operable and attached directly to the frame. Often available in significantly larger sizes than accompanying operating windows.

Rails

The horizontal part of a sash, door panel or screen.

Rough Opening

The opening in the wall where a window or door unit is to be installed. Openings are larger than the size of the unit to allow room for insulation.

Round Top

An arched window that is directly glazed to the frame. Add visual interest to a room and natural light.

Sash

The operating and/or stationary portion of the window that holds the glass and is separate from the frame.

Screens

A close-mesh woven material of metal or fiberglass attached to an aluminum or wood surround. Screens inhibit entry of insects, yet allow for light, air and unobstructed views.

Side Jamb

The left and right vertical pieces forming the frame on a window or door.

Sill

The lower, horizontal piece of a window or exterior door frame that supports the frame.

Single Hung

A window very similar to a double hung, but only the bottom sash moves up and down.

Stationary

A non-operating sash, panel or unit.

Stiles

The upright or vertical members of the framework of a sash, door, screen or other panel assembly.

Ultrex®

A pultruded composite material made of resin and glass fibers with an integrated proprietary finish.

Unit

One single window or door.

Weather-stripping

A strip of resilient material designed to seal the window or door frame in order to reduce air and water infiltration.



Find even more window replacement insights and ideas
on the [Infinity YouTube channel](#)

Infinity Double Hung

Unit Features.....	1
Lite Options	3
Minimum and Maximum Guidelines	4
Certified Sizes and Ratings.....	5
STC/OITC Glass Values	6
Mulling Guidelines	7
1/2" Mullion Reinforcement Guidelines	8
Measurement Conversions: Operable Units	9
Measurement Conversions: Transom and Picture.....	10
Measurement Conversions: Egress	11
Section Details: Operator	12
Section Details: Fixed Upper Sash.....	13
Section Details: Picture/Transom.....	14
Section Details: Casing Options.....	15
Section Details: Mullions	16
Section Details: 1/2" Mull Reinforcement	17
Interior Frame Accessories	18

Infinity Double Hung

Unit Features

Infinity Double Hung: NDH

Infinity Double Hung Transom: NDHTR

Infinity Double Hung Picture: NDHP

Ultrex® Pultruded Fiberglass Frame:

- Frame thickness: 31/32" (25) head jamb, 31/32" (25), side jamb, 25/32" (20) sill, flat bottom sill with 8 degree bevel
- Frame depth: 2 7/8" (73)
- Exterior colors: Stone White, Sierra, Cashmere, Pebble Gray, Bahama Brown, Bronze, Ebony
- Interior colors: Stone White, Sierra, Ebony, Bronze, EverWood™

Ultrex® Pultruded Fiberglass Sash:

- Sash thickness: 1 3/8" (35)
- Different sash option allows unequal sash heights, unique lite cuts for each sash or different glazing in each sash
- Operable sash tilts to interior for cleaning or removal
- Sash are replaceable but cannot be re-glazed
- Exterior colors: Stone White, Sierra, Cashmere, Pebble Gray, Bahama Brown, Bronze, Ebony
- Interior colors: Stone White, Sierra, Ebony, Bronze, EverWood™

Hardware:

- Lock and keeper:
 - Mounted at the center of the top check rail or 12" (305) on center from either end on dual lock unit
 - Zinc die-cast
- Sash lift:
 - Factory drilled for a bottom sash lift
 - Single lock units receive single lift; dual locks unit receive double lifts
 - Zinc die-cast
- Balance system:
 - Coil spring block and tackle with nylon cord and fiber filled nylon clutch
 - Allows the sash to raise or lower from desired position
- Bottom sash tilt latches:
 - Spring loaded tilt latches attached to upper corners of sash and operated with a button on the lock for easy tilting and sash removal
 - Tilt latches are mounted to the window stile and hidden under the check rail cover for a clean look
- Top sash tilt latches:
 - Spring loaded tilt latches attached to upper corners of sash
 - Injection molded nylon - white, black or beige
 - Hidden from view in the frame header when window is closed
- Top sash hanger (fixed upper sash only):
 - Attached to the frame securing the top sash making it stationary
 - Metal stamped
 - Color: white or black
- Optional factory applied Window Opening Control Device
 - Available on all operable units
 - Color: white, black or beige
 - This device works in accordance to ASMT F2090-17 Standard Specification for Window Fall Prevention Devices with Emergency Escape (Egress) Release Mechanisms.

Weather Strip:

- Frame:
 - Jamb: foam filled bulb with flexible TPE skin
 - Color: white, black or beige
 - Parting stop: PVC with flexible hinged wand seal
 - Color: white, black or beige
- Sash:
 - Bottom sash: white, black or beige hollow foam bulb type
 - Check rail: white, black or beige, PVC with flexible hinged wand seal
- Stationary units:
 - Continuous, foam weather strip at perimeter of sash
 - Color: White, Black or Beige

Unit Features

Insect Screens:

- Full screen
- Optional half screen
- Extruded aluminum frame: 0.050" wall thickness
- Standard screen mesh material: charcoal fiberglass
- Optional screen mesh material: high transparency screen
- Corners are mitered and joined with an internal corner key, which are not visible
- Friction fit pins are integrated into the side of the screen
- Frame color: matches exterior frame color

Glass:

- Glazing seal: silicone bedding on interior and exterior
- Standard glass is insulating Low E2 with Argon or air
- Optional glazing available: Low E1 with Argon or air, Low E3 with Argon or air, or Low E3/ERS with Argon or air, tempered, obscure
- Decorative glass options include Glue Chip, Rain, Reed, Narrow Reed, or Frost
- Decorative glass is not available with Low E1, Low E3/ERS, or STC/OITC
- Rain, Reed and Narrow Reed not available with SDL
- SDL available on Frost, annealed or tempered glass
- SDL available on Glue Chip, tempered glass required
- Insulating glass will be altitude adjusted with capillary tubes for higher elevations
- Argon gas is not available for elevations that require capillary tubes

Simulated Divided Lites (SDL):

- 7/8" (22) or 1 1/8" (29) SDL bar (interior and exterior)
- 2 11/32" (30) simulated rail only (interior and exterior)
- Exterior color: matched to unit exterior
- Interior color: matched to interior
- Pattern: equal rectangular, cottage, prairie, check rail and oriel

Gilles-Between-the-Glass (GBG):

- 23/32" (18) or 1" (25) contoured aluminum bar
- Exterior: Customer selection option available. All exterior color options.
- The exterior GBG color is designed to best match the unit exterior color when used with Low E glass. The use of different types of glazing options may alter the exterior GBG color appearance
- Interior color: White, Satin Taupe, Sierra, Bronze and Ebony
- Pattern: equal rectangular, cottage, prairie, check rail and oriel
- GBG's are not available with dual 4.7mm glass panes. Refer to OMS for availability.

NOTE: GBG may not be available or may require tempered glass if the glass size is greater than 16 square feet or if the short side dimension is greater than 48". Please contact your local Infinity Retailer or Infinity Support at 800-372-1072 to determine if GBG is available for glass sizes exceeding these dimensions.

Infinity Double Hung

Lite Options

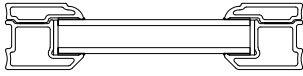

Insulating Glass

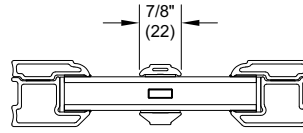

Insulating Glass
 7/8" SDL w/ spacer bar

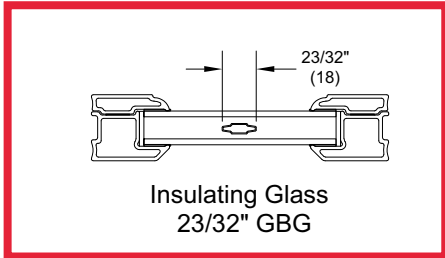

Insulating Glass
 23/32" GBG

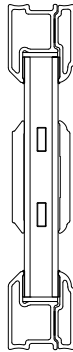

Insulating Glass
 SDL Simulated Rail
 w/spacer bar

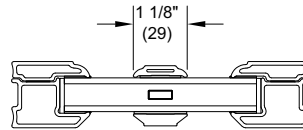

Insulating Glass
 1 1/8" SDL w/ spacer bar

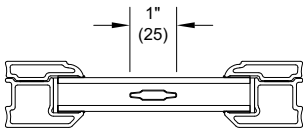

Insulating Glass
 1" GBG

Minimum and Maximum Guidelines

Minimum and Maximum Frame Size Guidelines - Standard Size												
Unit Type		Minimum Frame Size				Maximum Frame Size				Maximum Glass		
		Width		Height		Width		Height				
		in	mm	in	mm	in	mm	in	mm	Sash Size	Sq. Feet	Sq. Meters
NDH	Equal Sash	14 3/8	(365)	25 5/8	(651)	48	(1219)	96	(2438)	regular	13 45/64	1.27
NDH	Cottage Style	14 3/8	(365)	30 1/8	(765)	48	(1219)	72	(1829)	small	8 3/64	0.75
										large	13 27/64	1.25
NDH	Oriel Style	14 3/8	(365)	30 1/8	(765)	48	(1219)	96	(2438)	small	10 31/32	1.02
										large	18 9/32	1.70
NDHP NDHTR	Picture Transom	18	(457)	16 3/8	(416)	75	(1905)	75	(1905)	regular	30	2.79

Minimum and Maximum Frame Size Guidelines - Expanded Size												
Unit Type		Minimum Frame Size				Maximum Frame Size				Maximum Glass		
		Width		Height		Width		Height				
		in	mm	in	mm	in	mm	in	mm	Sash Size	Sq. Feet	Sq. Meters
NDH	Equal Sash	48 1/32	(1220)	25 5/8	(651)	54	(1372)	85	(2159)	regular	13 11/16	1.27
NDH	Cottage Style	48 1/32	(1220)	30 1/8	(765)	54	(1372)	60	(1524)	small	7 1/2	0.70
										large	12 1/2	1.16
NDH	Oriel Style	48 1/32	(1220)	30 1/8	(765)	54	(1372)	85	(2159)	small	10 15/16	1.02
										large	18 1/4	1.70

NOTE: Fixed upper sash required on certain sizes. Contact Infinity Support for more information.

For Glue Chip and Frost, maximum short frame side is 63 1/4".

For Rain, Reed and Narrow Reed, vertical pattern orientation maximum frame width size 63 1/4".

For Reed and Narrow Reed, horizontal pattern orientation maximum sash height 61 1/8" for operating unit, 63 1/4" for transom and picture units.

Tempered glass may be required if the glass size is greater than 23 square feet. Please contact your local Infinity Retailer or Infinity Support at 800-372-1072 to determine available glass options on units exceeding this size.

Infinity Double Hung

Certified Sizes and Ratings

Product	Air Tested to psf	Water Tested to psf	Design Pressure (DP)	Certification Rating	Max Overall Width		Max Overall Height	
					in	mm	in	mm
Infinity Double Hung	1.57	3.76	25	LC-PG25-H	54	(1372)	85	(2159)
Infinity Double Hung	1.57	4.6	30	LC-PG30-H	48	(1219)	96	(2438)
Infinity Double Hung Picture	1.57	4.5	30	LC-PG30-FW	72	(1829)	72	(1829)
	1.57	4.5	30	LC-PG30-FW	60	(1524)	75	(1905)
	1.57	4.5	25	LC-PG25-FW	75	(1905)	75	(1905)

Infinity Double Hung

STC/OITC Glass Values

STC/OITC ratings are shown in the chart below. Infinity's STC/OITC values are provided by third party ASTM testing and reports. The STC/OITC Upgrade option incorporates variable glass thickness or laminate (L) to increase STC/OITC performance and improve sound abatement.

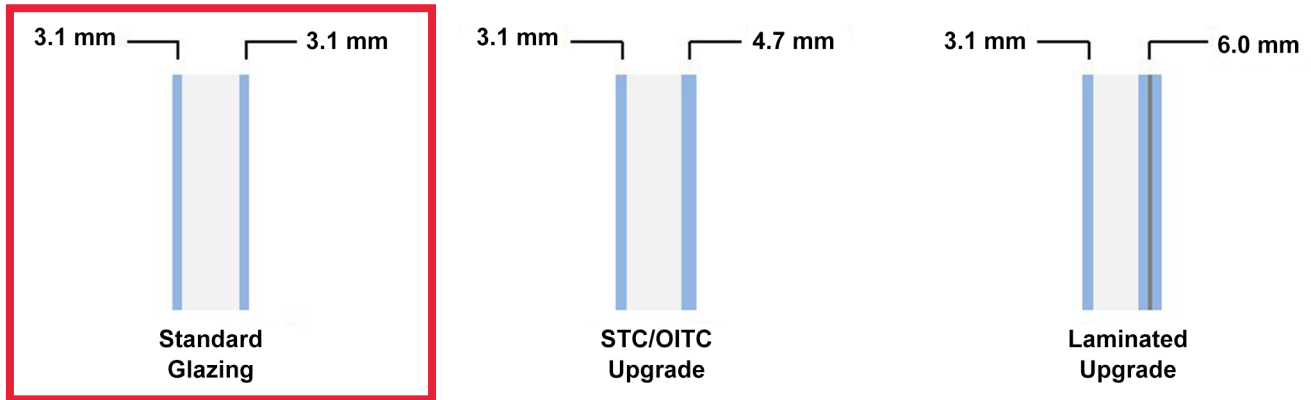

Product Type	Exterior Glazing	Airspace	Interior Glazing	STC	OITC
Full Frame Double Hung	1/8" (3.1)	15/32" (11.5)	1/8" (3.1)	26	22
	1/8" (3.1)	3/8" (9.8)	3/16" (4.7)	30	26
	1/8" (3.1)	5/16" (8.0)	1/4" (6.0L)	32	27
Full Frame Double Hung Picture	1/8" (3.1)	15/32" (11.5)	1/8" (3.1)	28	25
	1/8" (3.1)	3/8" (9.8)	3/16" (4.7)	31	27
	1/8" (3.1)	5/16" (8.0)	1/4" (6.0L)	33	28

Infinity Double Hung

Mulling Guidelines

Factory Mullered Double Hung Assemblies

- Assemblies up to 4 units wide by 1 unit high
 - MAXIMUM ROUGH OPENING not to exceed 113" (2870) x 85 1/2" (2172)
- Assemblies up to 1 unit wide by 2 units high
 - MAXIMUM ROUGH OPENING not to exceed 73" (1854) x 96" (2438)

NOTE: Field mulling beyond the above limitations is not recommended.

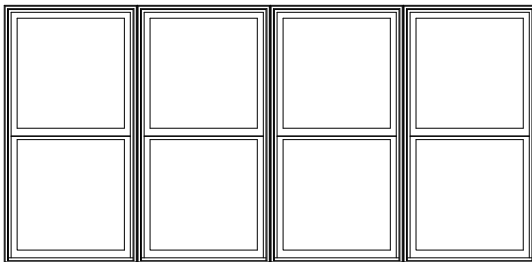
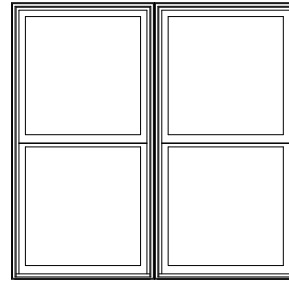
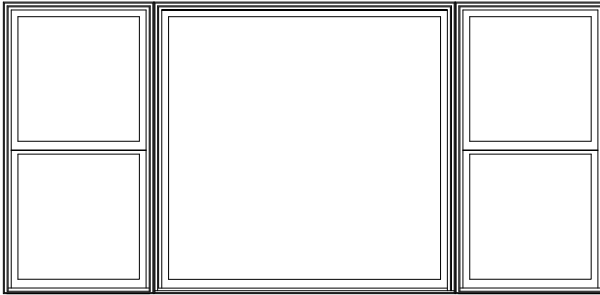

Rough Opening Assemblies

- WIDTH:
 - Frame Width = Single unit Rough Opening with MINUS 1"
 - Total Rough Opening Width = ADD all frame widths PLUS 1"
- Height:
 - Frame Height = Single unit Rough Opening height MINUS 1/2"
 - Total Rough Opening Height = ADD all frame heights PLUS 1/2"

1/2" Mullion Reinforcement Guidelines

Factory Mullered 1/2" Mull Reinforcement Double Hung Assemblies

- Assemblies up to 4 units wide by 1 unit high
 - MAXIMUM ROUGH OPENING not to exceed 113" (2870) x 96 1/2" (2451)
- Assemblies up to 1 unit wide by 2 units high
 - MAXIMUM ROUGH OPENING not to exceed 73" (1854) x 96 1/2" (2451)
- Assemblies up to 2 units wide by 2 units high
 - MAXIMUM ROUGH OPENING not to exceed 97 1/2" (2477) x 96 1/2" (2451)
 - MAXIMUM ROUGH OPENING not to exceed 113" (2870) x 86 1/2" (2197)

NOTE: Field mulling beyond the above limitations is not recommended.

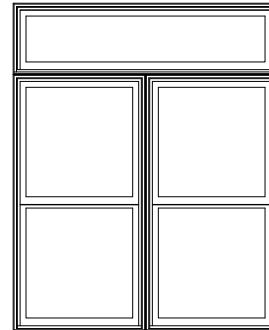
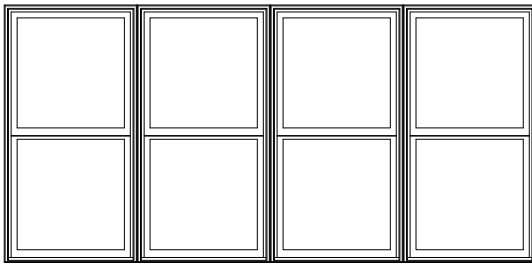
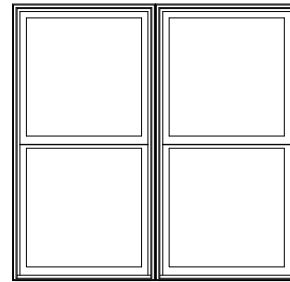
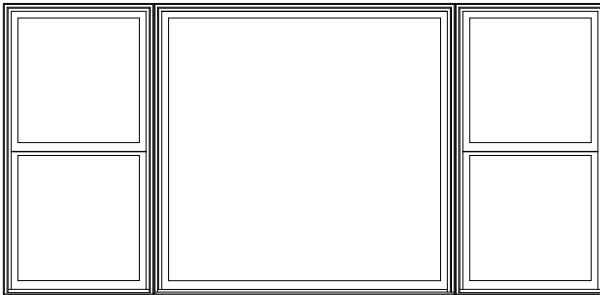

Rough Opening Assemblies

- WIDTH:
 - Frame Width = Single unit Rough Opening with MINUS 1"
 - Total Rough Opening Width = ADD all frame widths PLUS 1/2" for each vertical Mull Reinforcement PLUS 1"
- HEIGHT:
 - Frame Height = Single unit Rough Opening height MINUS 1/2"
 - Total Rough Opening Height: ADD all frame heights PLUS 1/2" for each horizontal Mull Reinforcement PLUS 1/2"

Measurement Conversions: Operable Units

Full Frame Double Hung Operating Unit						
Unit Measurements		Width		Height		
From	To					
Rough Opening		in	mm		in	mm
Masonry Opening	Rough Opening	+ 1/2	(13)		+ 1/4	(6)
Masonry Opening w/ BMC	Rough Opening	-2 1/4	(57)		-1 11/16	(43)
OM of Frame	Rough Opening	+ 1	(25)		+ 1/2	(13)
Daylight Opening	Rough Opening	+ 6 13/32	(163)		+ 8 1/4	(210)
Frame		in	mm		in	mm
OM of BMC	OM of Frame	-2 3/4	(70)		-2 1/16	(52)
Daylight Opening	OM of Frame	+ 5 13/32	(137)	x 2	+ 7 3/4	(197)
Top Sash (Equal Sash)		in	mm		in	mm
OM of Frame	OM of Top Sash	-2 5/32	(54)	+ 2	-19/32	(15)
Daylight Opening	OM of Top Sash	+ 3 1/4	(83)		+ 3 1/4	(83)
Bottom Sash (Equal Sash)		in	mm		in	mm
OM of Frame	OM of Bottom Sash	-2 5/32	(54)	+ 2	-3/16	(5)
Daylight Opening	OM of Bottom Sash	+ 3 1/4	(83)		+ 3 1/4	(83)
Top Sash (Cottage Height)		in	mm		in	mm
OM of Frame	OM of Top Sash	-2 5/32	(54)	x 0.4	-1/32	(1)
Daylight Opening	OM of Top Sash	+ 3 1/4	(83)		+ 3 1/4	(83)
Bottom Sash (Cottage Height)		in	mm		in	mm
OM of Frame	OM of Bottom Sash	-2 5/32	(54)	x 0.6	-3/4	(19)
Daylight Opening	OM of Bottom Sash	+ 3 1/4	(83)		+ 3 1/4	(83)
Top Sash (Oriel Height)		in	mm		in	mm
OM of Frame	OM of Top Sash	-2 5/32	(54)	x 0.6	-1 5/32	(30)
Daylight Opening	OM of Top Sash	+ 3 1/4	(83)		+ 3 1/4	(83)
Bottom Sash (Oriel Height)		in	mm		in	mm
OM of Frame	OM of Bottom Sash	-2 5/32	(54)	x 0.4	+ 3/8	(-9)
Daylight Opening	OM of Bottom Sash	+ 3 1/4	(83)		+ 3 1/4	(83)
Glass		in	mm		in	mm
Daylight Opening	Glass	+ 1 1/16	(27)		+ 1 1/16	(27)
Full Screen		in	mm		in	mm
OM of Frame	OM of Screen	-1 27/32	(47)		-1 17/32	(39)
Daylight Opening	OM of Screen	+ 3 9/16	(90)	x 2	+ 6 3/16	(157)
Half Screen		in	mm		in	mm
OM of Frame	OM of Screen	-1 27/32	(47)	+ 2	-7/32	(6)
Daylight Opening	OM of Screen	+ 3 9/16	(90)		+ 3 21/32	(92)
CottageScreen		in	mm		in	mm
OM of Frame	OM of Screen	-1 27/32	(47)		-1 17/32	(39)
Daylight Opening (S1)	OM of Screen	+ 3 9/16	(90)	+ 0.4	+ 6 23/32	(170)
Oriel Screen		in	mm		in	mm
OM of Frame	OM of Screen	-1 27/32	(47)		-1 17/32	(39)
Daylight Opening (S1)	OM of Screen	+ 3 9/16	(90)	+ 0.6	+ 5 13/16	(148)

Measurement Conversions: Transom and Picture

Full Frame Double Hung Transoms					
Unit Measurements		Width		Height	
From	To				
Rough Opening		in	mm	in	mm
OM of Frame	Rough Opening	+ 1	(25)	+ 1/2	(13)
Masonry Opening	Rough Opening	+ 1/2	(13)	+ 1/4	(6)
Masonry Opening w/ BMC	Rough Opening	-2 1/4	(57)	-1 11/16	(43)
Daylight Opening	Rough Opening	+ 6 13/32	(163)	+ 5 7/8	(149)
Frame		in	mm	in	mm
OM of BMC	OM of Frame	-2 3/4	(70)	-2 1/16	(52)
Daylight Opening	OM of Frame	+ 5 13/32	(137)	+ 5 11/32	(136)
Sash		in	mm	in	mm
OM of Frame	OM of Sash	-2 5/32	(54)	-2 3/32	(53)
Daylight Opening	OM of Sash	+ 3 1/4	(83)	+ 3 1/4	(83)
Glass		in	mm	in	mm
Daylight Opening	Glass	+ 1 1/16	(27)	+ 1 1/16	(27)

Full Frame Double Hung Picture					
Unit Measurements		Width		Height	
From	To				
Rough Opening		in	mm	in	mm
OM of Frame	Rough Opening	+ 1	(25)	+ 1/2	(13)
Masonry Opening	Rough Opening	+ 1/2	(13)	+ 1/4	(6)
Masonry Opening w/ BMC	Rough Opening	-2 1/4	(57)	-1 11/16	(43)
Daylight Opening	Rough Opening	+ 6 13/32	(163)	+ 5 7/8	(149)
Frame		in	mm	in	mm
OM of BMC	OM of Frame	-2 3/4	(70)	-2 1/16	(52)
Daylight Opening	OM of Frame	+ 5 13/32	(137)	+ 5 11/32	(136)
Sash		in	mm	in	mm
OM of Frame	OM of Sash	-2 5/32	(54)	-2 3/32	(53)
Daylight Opening	OM of Sash	+ 3 1/4	(83)	+ 3 1/4	(83)
Glass		in	mm	in	mm
Daylight Opening	Glass	+ 1 1/16	(27)	+ 1 1/16	(27)

Measurement Conversions: Egress

Egress Conversions		
Equal Sash Egress Minimum Opening and Conversions from Frame Size		
Minimum Value for Net Clear Opening	Desired Dimension	Formula
20 in	Egress opening width, in	= NDH frame OM width - 2.894
24 in	Egress opening height, in	= (NDH frame OM height /2) - 5.791
5.7 ft2	Egress opening area, ft2	= ((Egress opening width, in) x (Egress opening height, in)) / 144

Egress Conversions		
Cottage Style Egress Minimum Opening and Conversions from Frame Size		
Minimum Value for Net Clear Opening	Desired Dimension	Formula
20 in	Egress opening width, in	= NDH frame OM width - 2.894
24 in	Egress opening height, in	= (NDH frame OM height x SR) - 5.231
5.7 ft2	Egress opening area, ft2	= ((Egress opening width, in) x (Egress opening height, in)) / 144

Egress Conversions		
Oriel Style Egress Minimum Opening and Conversions from Frame Size		
Minimum Value for Net Clear Opening	Desired Dimension	Formula
20 in	Egress opening width, in	= NDH frame OM width - 2.894
24 in	Egress opening height, in	= (NDH frame OM height x SR) - 5.425
5.7 ft2	Egress opening area, ft2	= ((Egress opening width, in) x (Egress opening height, in)) / 144

*NOTE: SR is the sash ratio of the smallest sash to the glass height (2/5 or 1/3)
Must meet/exceed all three minimum values to meet egress. Limited travel may affect egress opening height.*

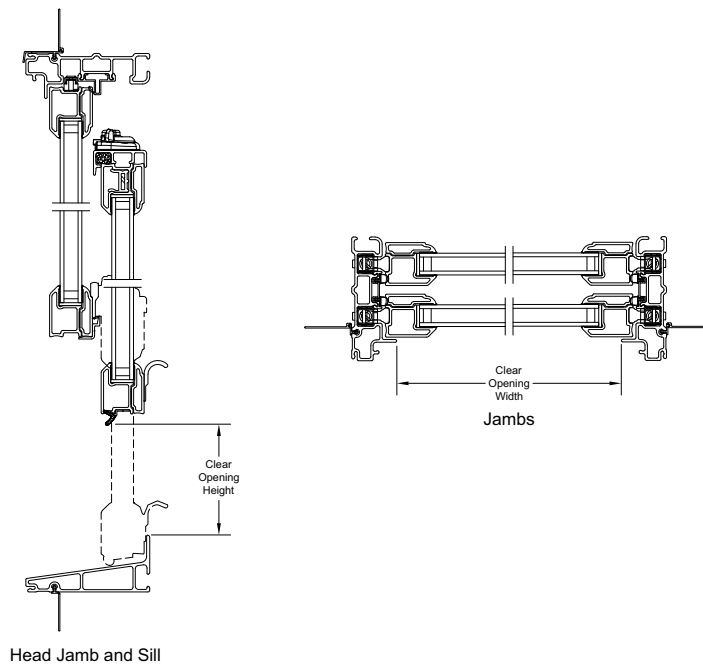

Infinity Double Hung

Section Details: Operator

Scale: 3" = 1' 0"

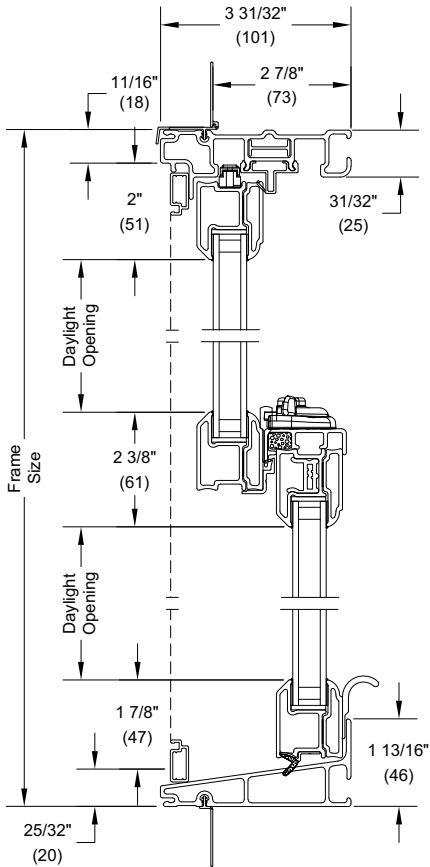

**Head Jamb and Sill
NDH w/ Full Screen**

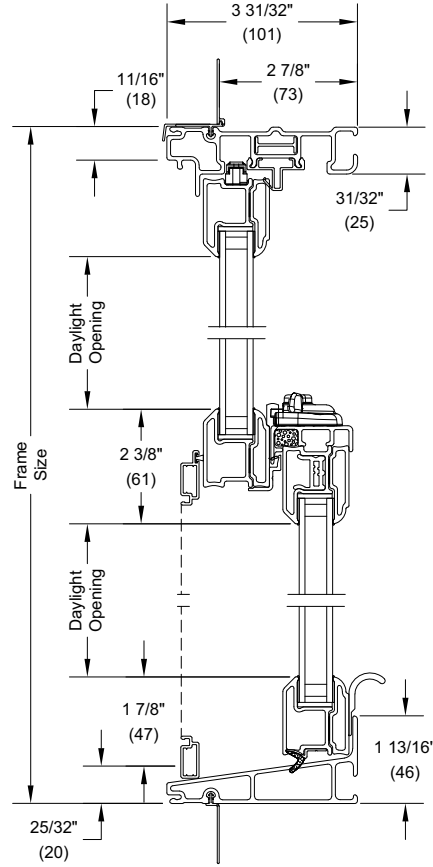

**Head Jamb and Sill
NDH w/ Half Screen**

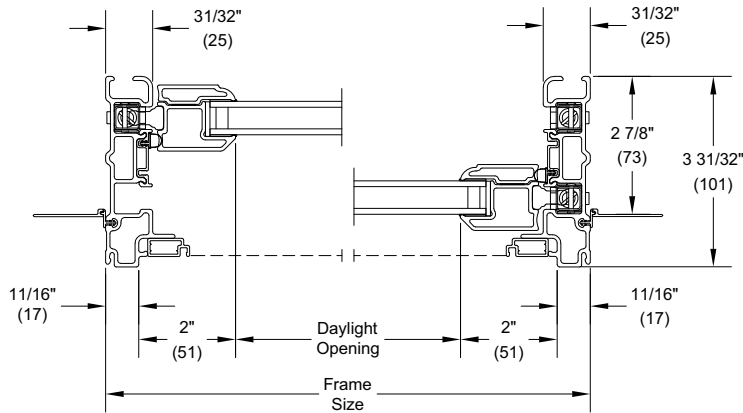

Jamb

Infinity Double Hung

Section Details: Fixed Upper Sash

Scale: 3" = 1' 0"

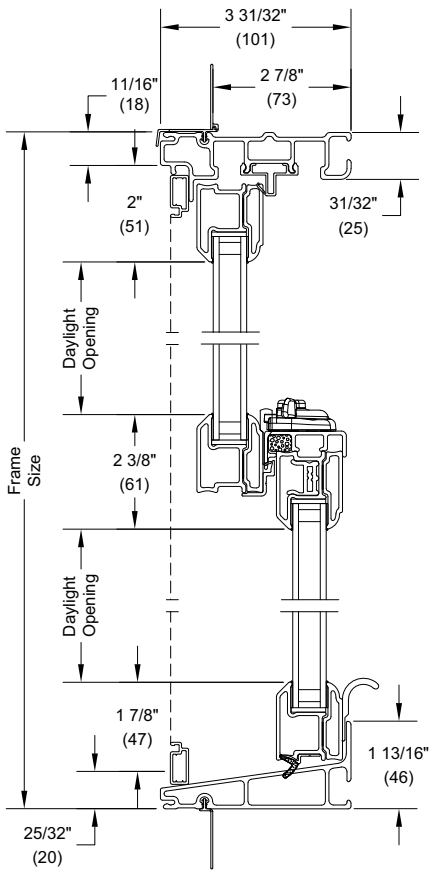

**Head Jamb and Sill
NDH w/ Full Screen**

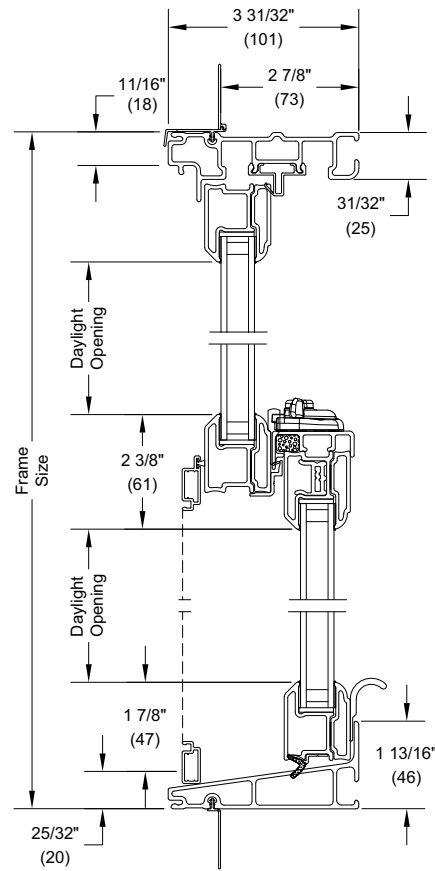

**Head Jamb and Sill
NDH w/ Half Screen**

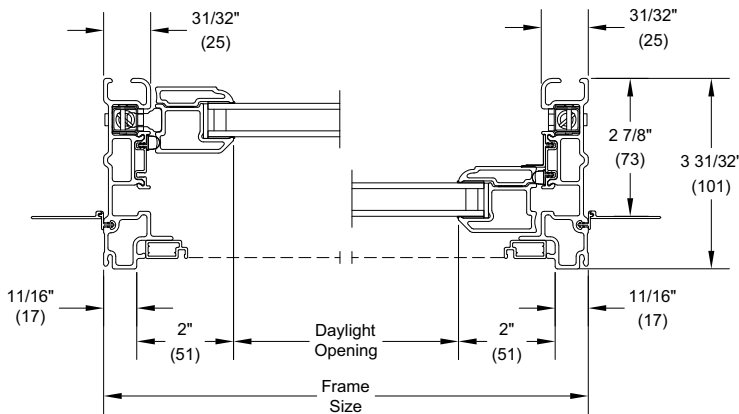

Jambs

Infinity Double Hung

Section Details: Picture/Transom

Scale: 3" = 1' 0"

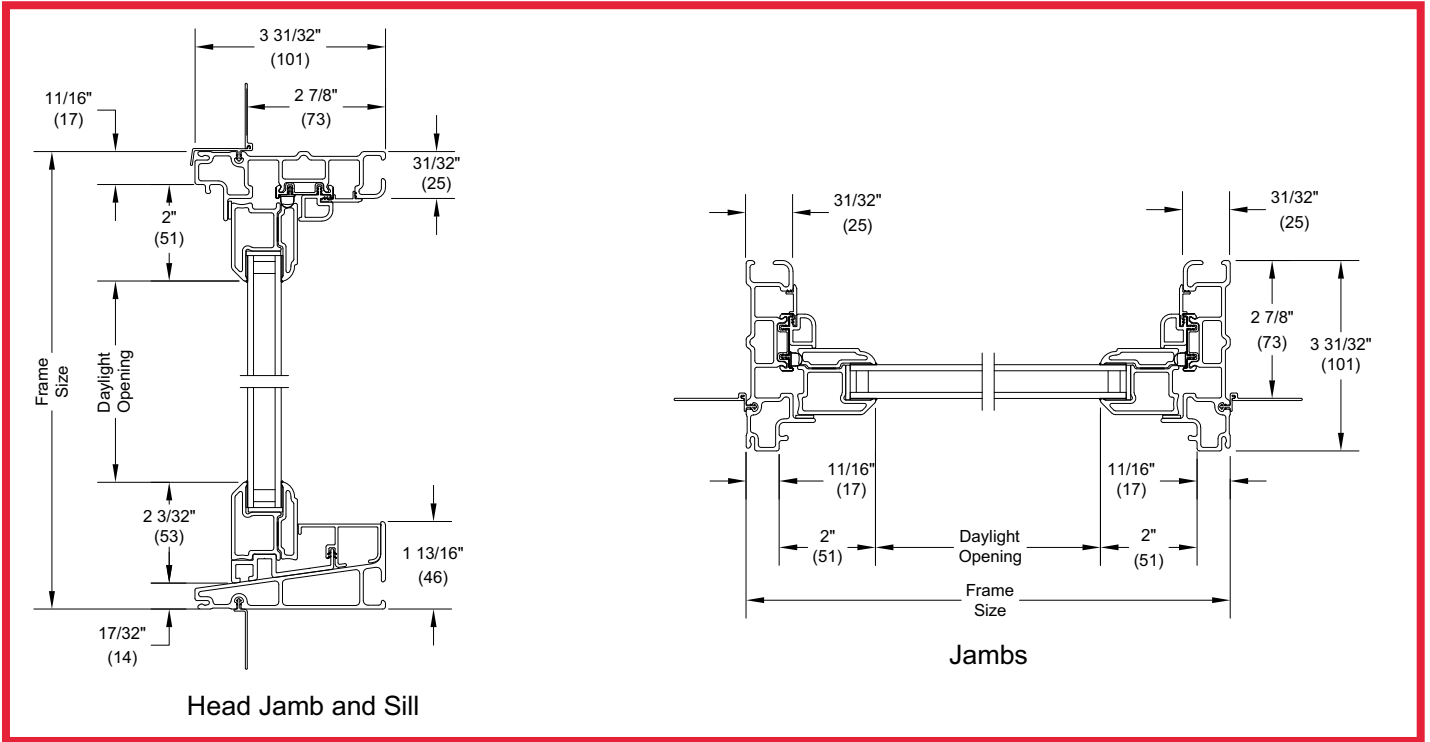

Infinity Double Hung

Section Details: Casing Options

Scale: 3" = 1' 0"

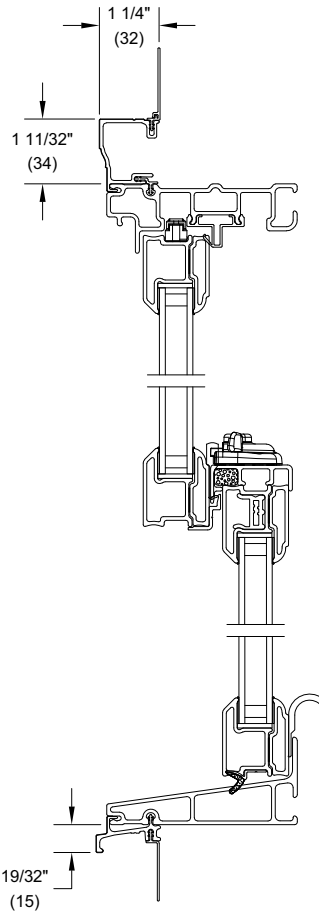

Brick Mould Casing

Infinity Double Hung

Section Details: Mullions

Scale: 3" = 1' 0"

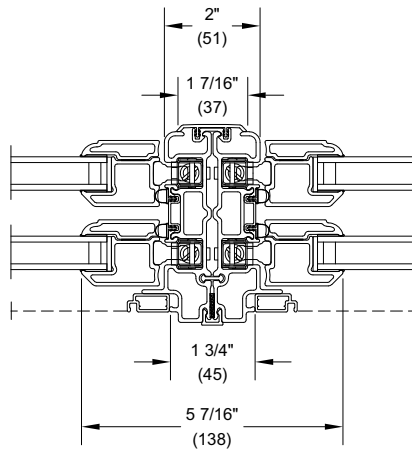

Vertical
Mullion-Operator/Operator

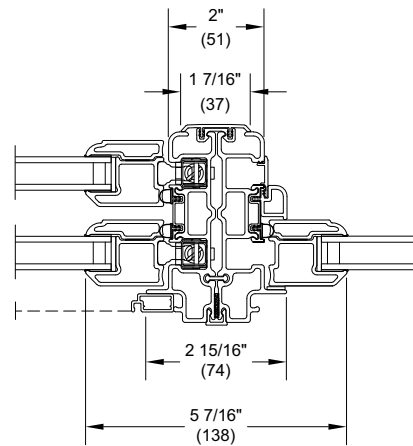

Vertical Mullion-Operator
/Picture

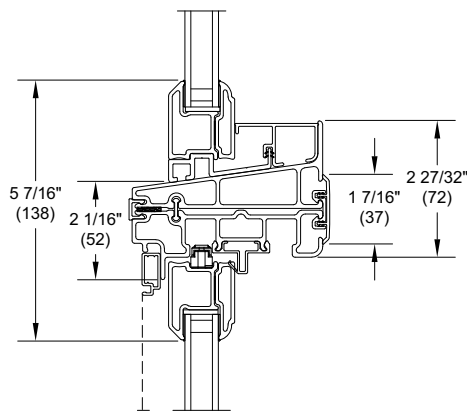

Transom muller over
Infinity Double Hung

Infinity Double Hung

Section Details: 1/2" Mull Reinforcement

Scale: 3" = 1' 0"

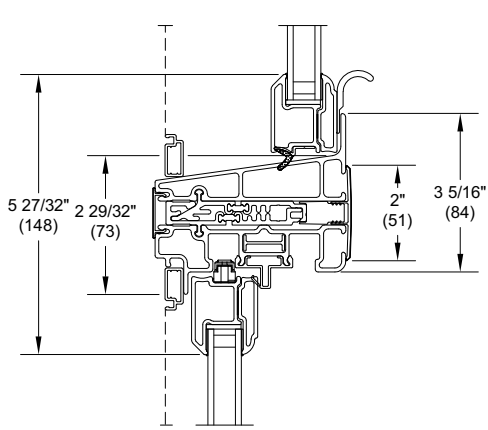

1/2" Mull Reinforcement
 Operator/Operator
 NDH

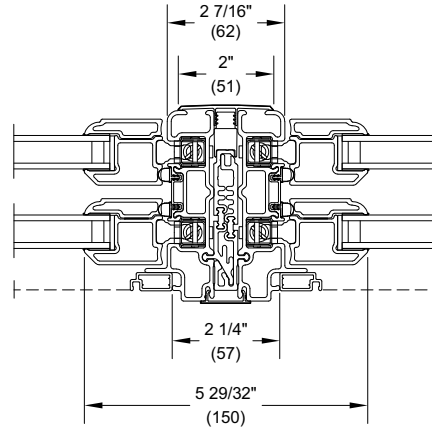

1/2" Mull Reinforcement
 Operator/Operator
 NDH

Infinity Double Hung

Interior Frame Accessories

Scale: 3" = 1' 0"

