

# Construction Details

Introduction .....	1
Ultimate Direct Glaze Polygon - 2x6 Frame Wood Siding .....	2
Ultimate Wood Direct Glaze Polygon - 2x6 Frame with Wood Siding .....	3
Ultimate Direct Glaze Polygon - 2x4 Frame with Stucco .....	4
Ultimate Wood Direct Glaze Polygon - 2x4 Frame with Stucco .....	5
Ultimate Direct Glaze Polygon - 2x4 Steel Stud with Brick Veneer .....	6
Ultimate Wood Direct Glaze Polygon - 2x4 Steel Stud with Brick Veneer .....	7
Ultimate Direct Glaze Polygon - Concrete Block with Brick Veneer .....	8
Ultimate Wood Direct Glaze Polygon - Concrete Block with Brick Veneer .....	9
Ultimate Direct Glaze Poly - Wood Siding Combination Wall Sheathing, WRB and Air Barrier .....	10
Ultimate Direct Glaze Polygon - Foam Plastic Insulated Sheathing (FPIS) over WRB .....	11
Ultimate Wood Direct Glaze Polygon - Foam Plastic Insulated (FPIS) under WRB .....	12
Ultimate Inswing French Door - Frame with Steel Siding .....	13
Ultimate Wood Inswing French Door - 2x6 Frame with Steel Siding .....	14
Structural Support Options .....	15
Modern Casement - 2x6 Frame with Stucco .....	16
Modern Casement - 2x6 Frame with Wall Sheathing .....	17



## Introduction

Marvin Windows and Doors is an industry leader in providing high quality and energy efficient windows and doors. To obtain these results, Marvin windows and doors need to be properly installed and maintained. Failure to review and utilize these construction methods can result in poor product performance, premature failure and unnecessary call backs. It is the responsibility of the architect, builder, installer, and subcontractors to comply with code requirements for their area and to utilize the best method for attachments and fastener selections.

This chapter covers the water seal requirements of the window and door installation and provides visual detail in drawing format of our installation instructions.

The water seal method can be thought of as primary and secondary methods and systems;

- **Primary water seal:** window exterior seal to the exterior coating or finish of the building
- **Secondary water seal:** window seal to the wall weather resistive barrier so that any leakage within the wall is managed and controlled.
- **Window panning system:** drains the RO area to the wall resistive barrier
- **RO air area seal:** prevents RO pressurization and air movement through the RO
- **Wall thermal barrier:** provides continuity of the wall system by installation placed around the window in the RO gap. Marvin has two systems for this; (1) batten installation system and (2) spray foam
- **Vapor seal:** is the least important of the seal systems. The vapor barrier provides continuity across the RO with the wall vapor barrier.

Units must be shimmed in the opening, true, level, and square. Shim a minimum of 3/8" above sill plate to provide unit clearance over panning.

Contact your Marvin representative if you have questions or need further technical assistance at 1-800-346-3363.

*NOTE: Details shown not typical and subject to change without notice. Always refer to your local code for proper construction and rough opening preparation.*

***Important!** Details are shown with small spaces between items for clarity, visualization, and illustrative purposes. Actual assembly details may vary. Contact Marvin Architectural for project specific aids.*

Step by step instructions with color illustrations on Marvin's recommended rough opening preparation can be found at <http://www.marvin.com/roprep/>

Ultimate Direct Glaze Polygon - 2x6 Frame Wood Siding

Scale: 3" = 1"0"

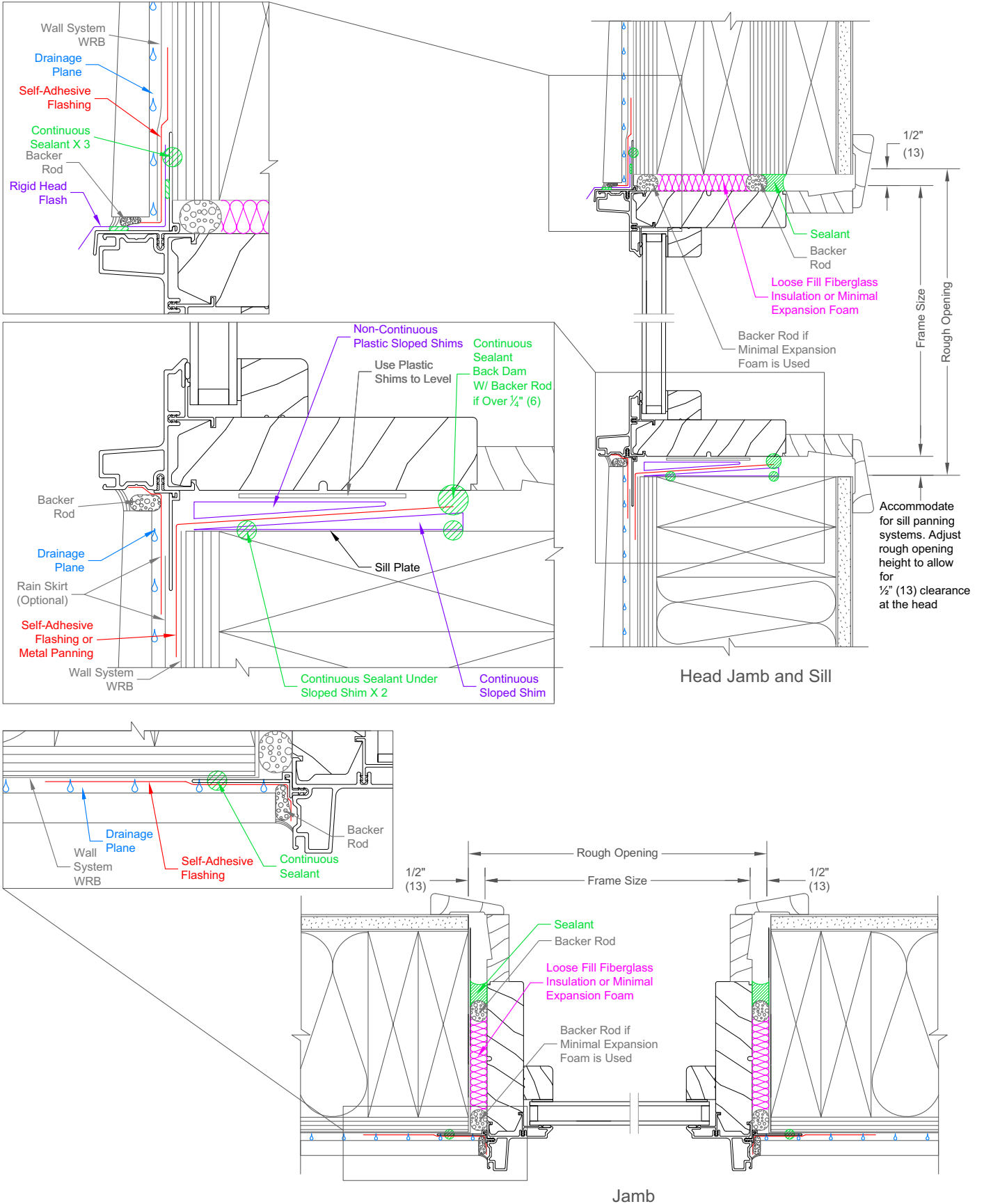

**Ultimate Wood Direct Glaze Polygon - 2x6 Frame with Wood Siding**

Scale: 3" = 1"0"

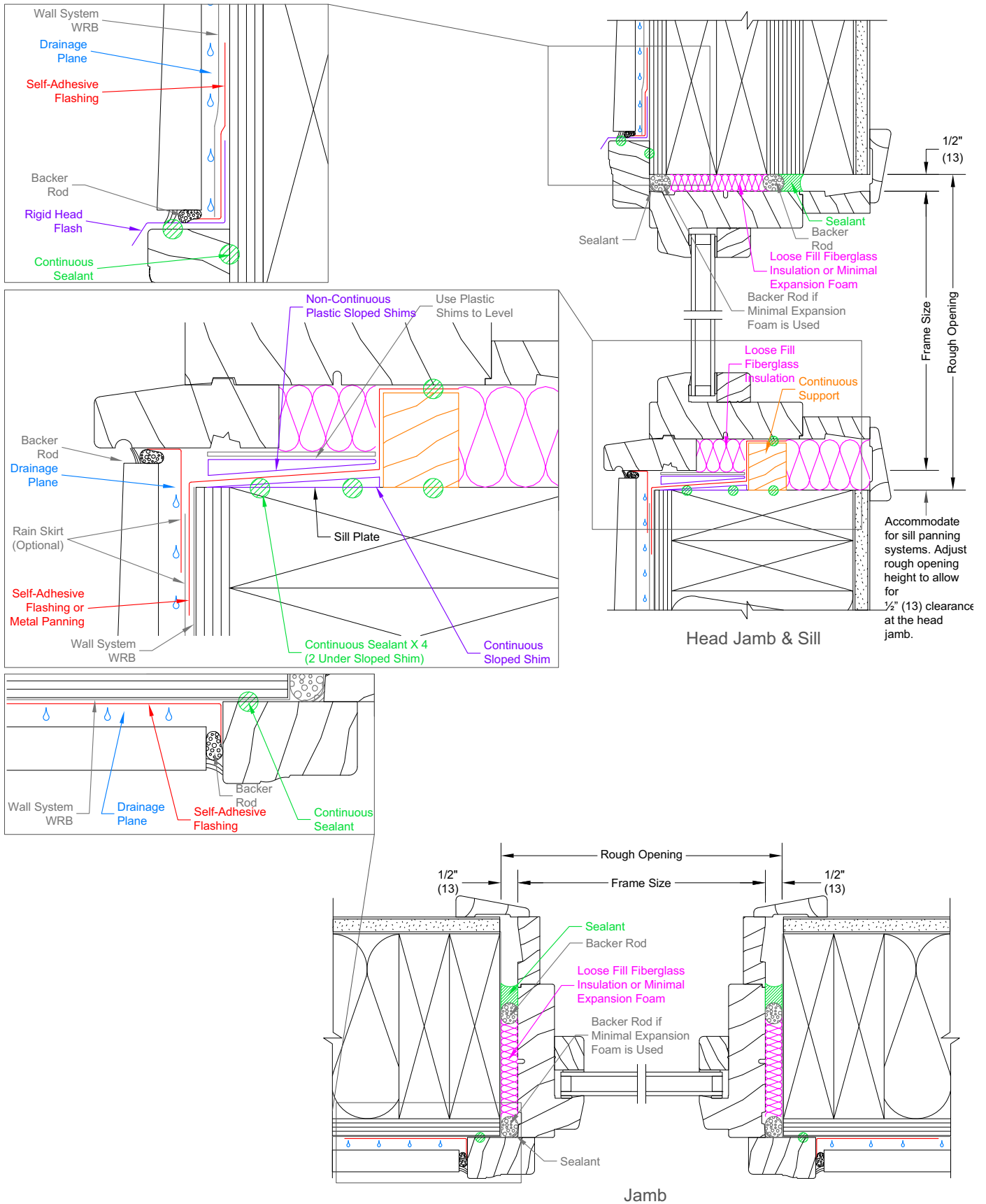

**Ultimate Direct Glaze Polygon - 2x4 Frame with Stucco**

Scale: 3" = 1'0"

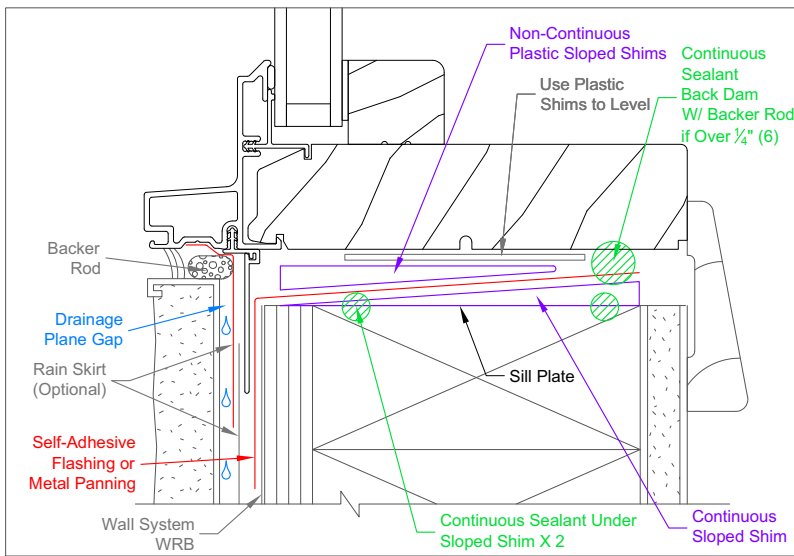
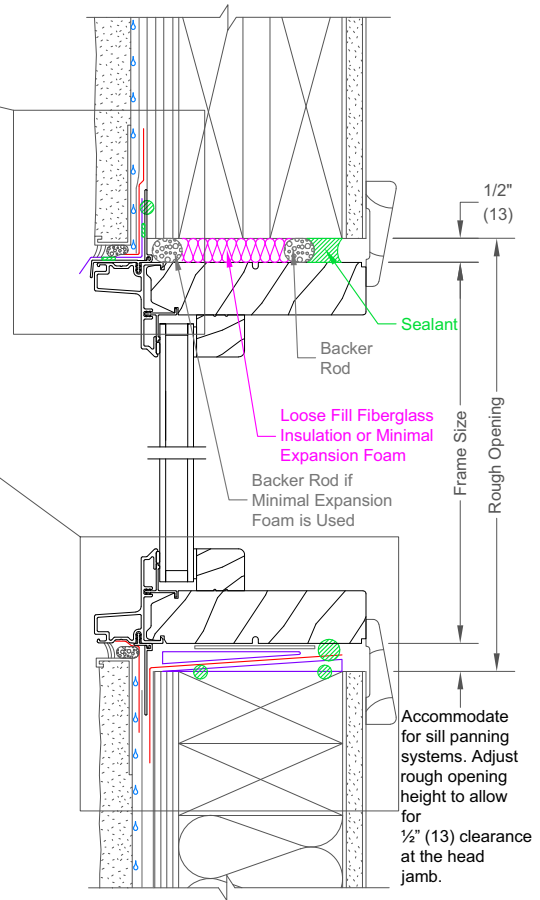
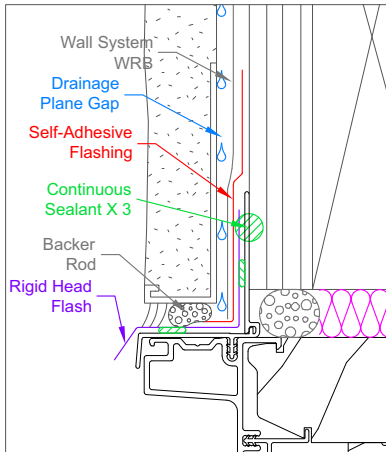

Head Jamb and Sill

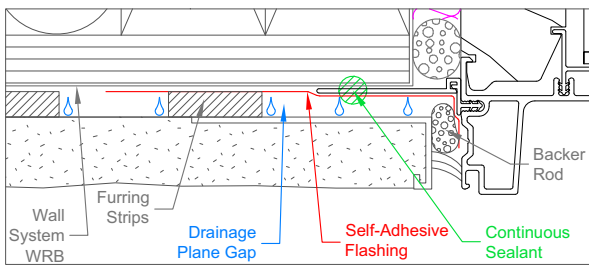

*NOTE: Engineered water management stucco product. See stucco manufacture for specific details required by water management system.*

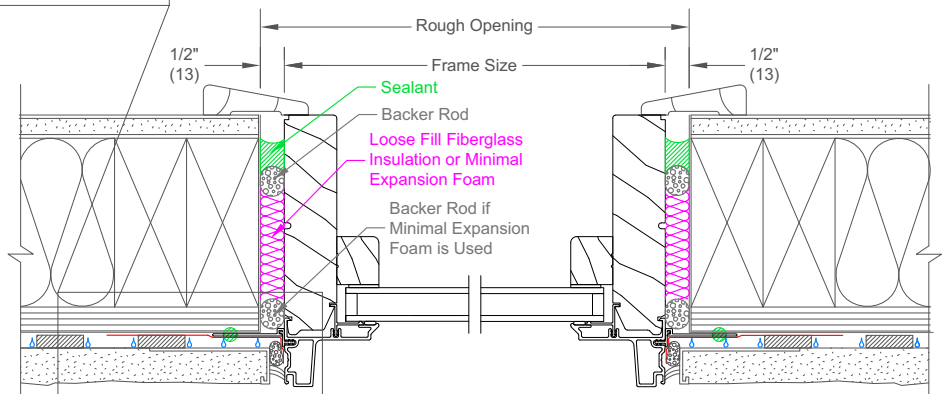

Jamb

**Ultimate Wood Direct Glaze Polygon - 2x4 Frame with Stucco**

Scale: 3" = 1'0"

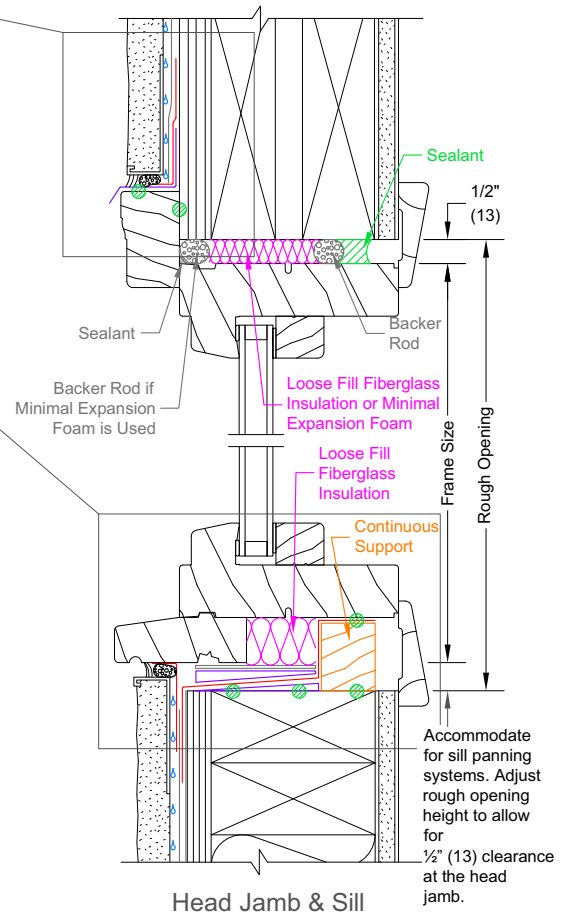
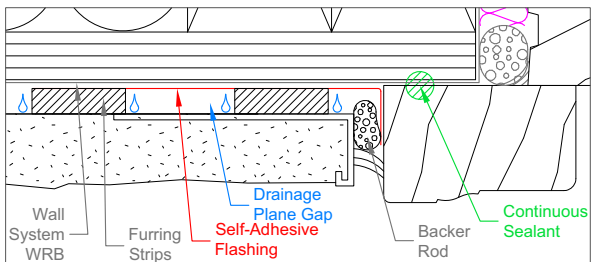
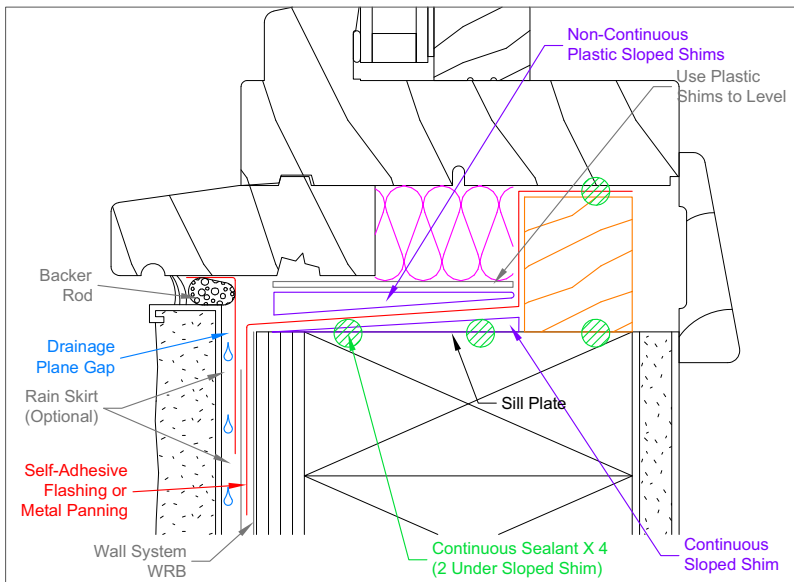
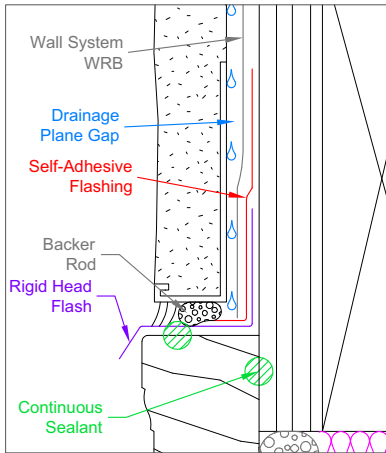

Head Jamb & Sill

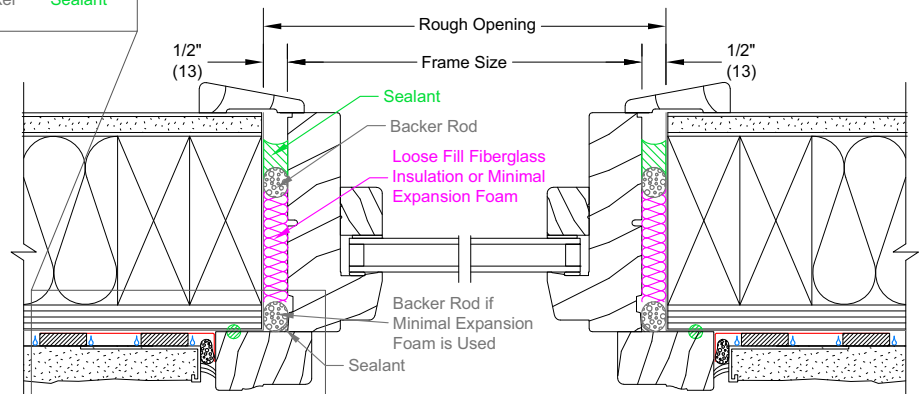

Jamb

**Ultimate Direct Glaze Polygon - 2x4 Steel Stud with Brick Veneer**

Scale: 3" = 1'0"

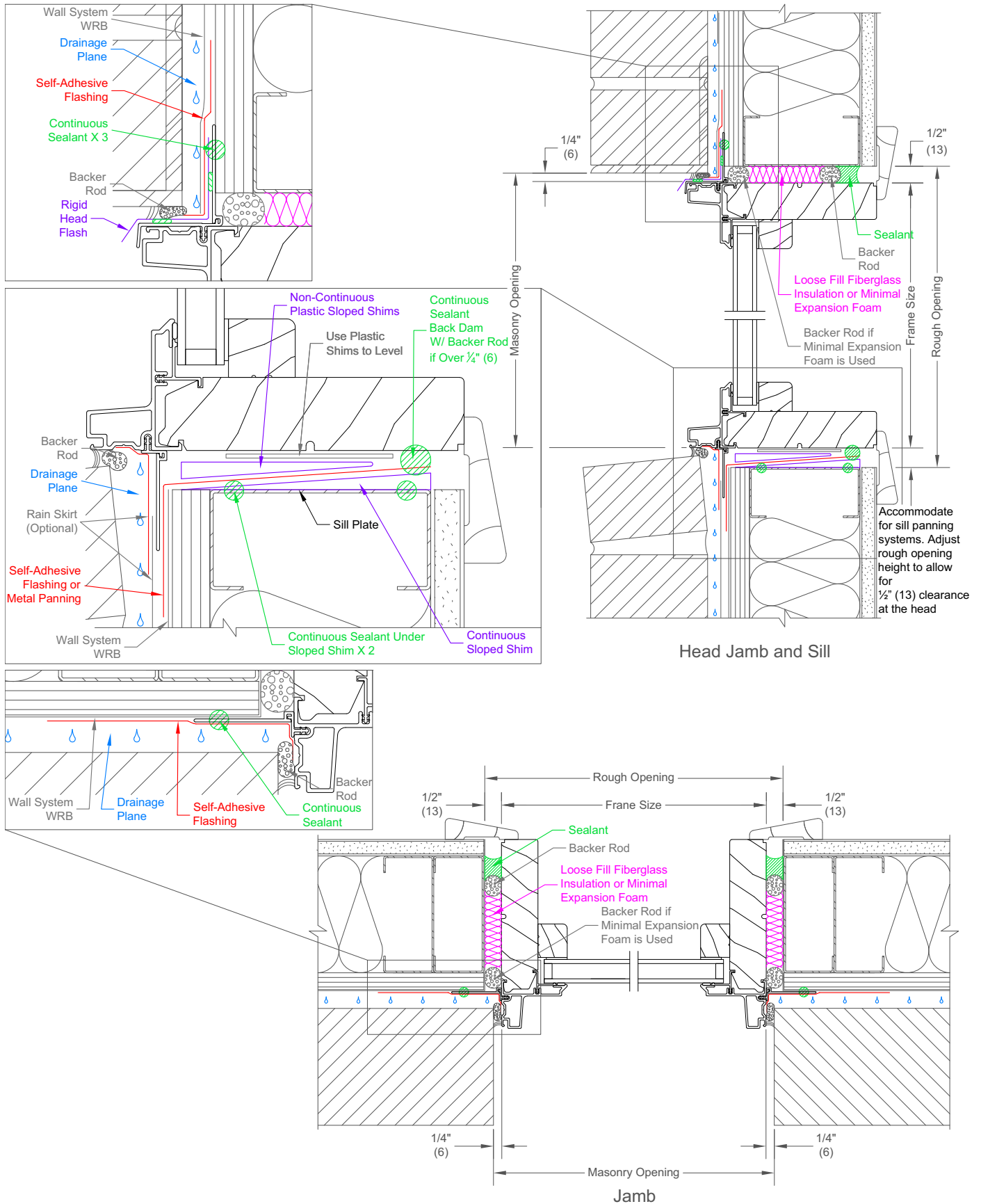



**Ultimate Wood Direct Glaze Polygon - 2x4 Steel Stud with Brick Veneer**

Scale: 3" = 1'0"

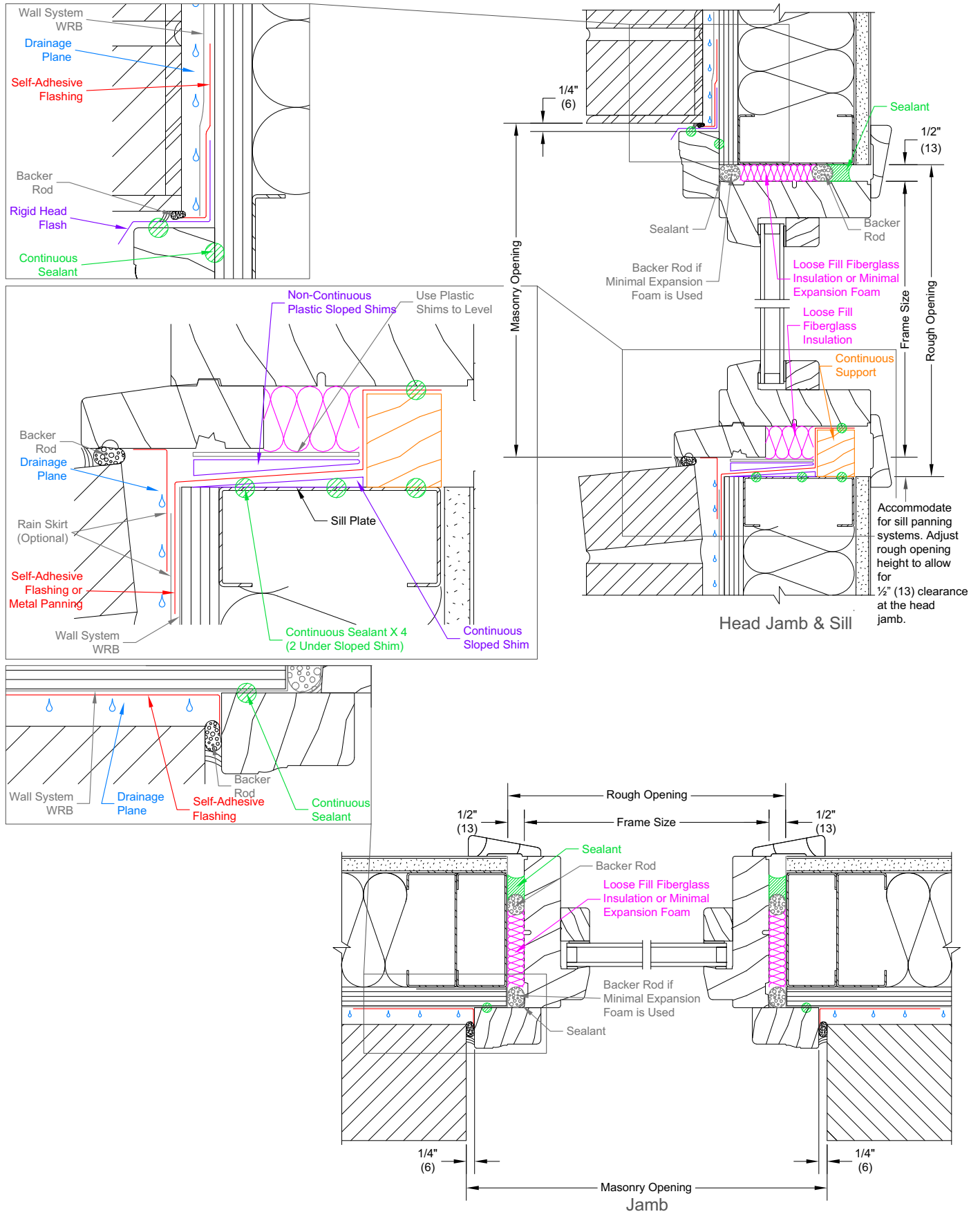

**Ultimate Direct Glaze Polygon - Concrete Block with Brick Veneer**

Scale: 3" = 1'0"

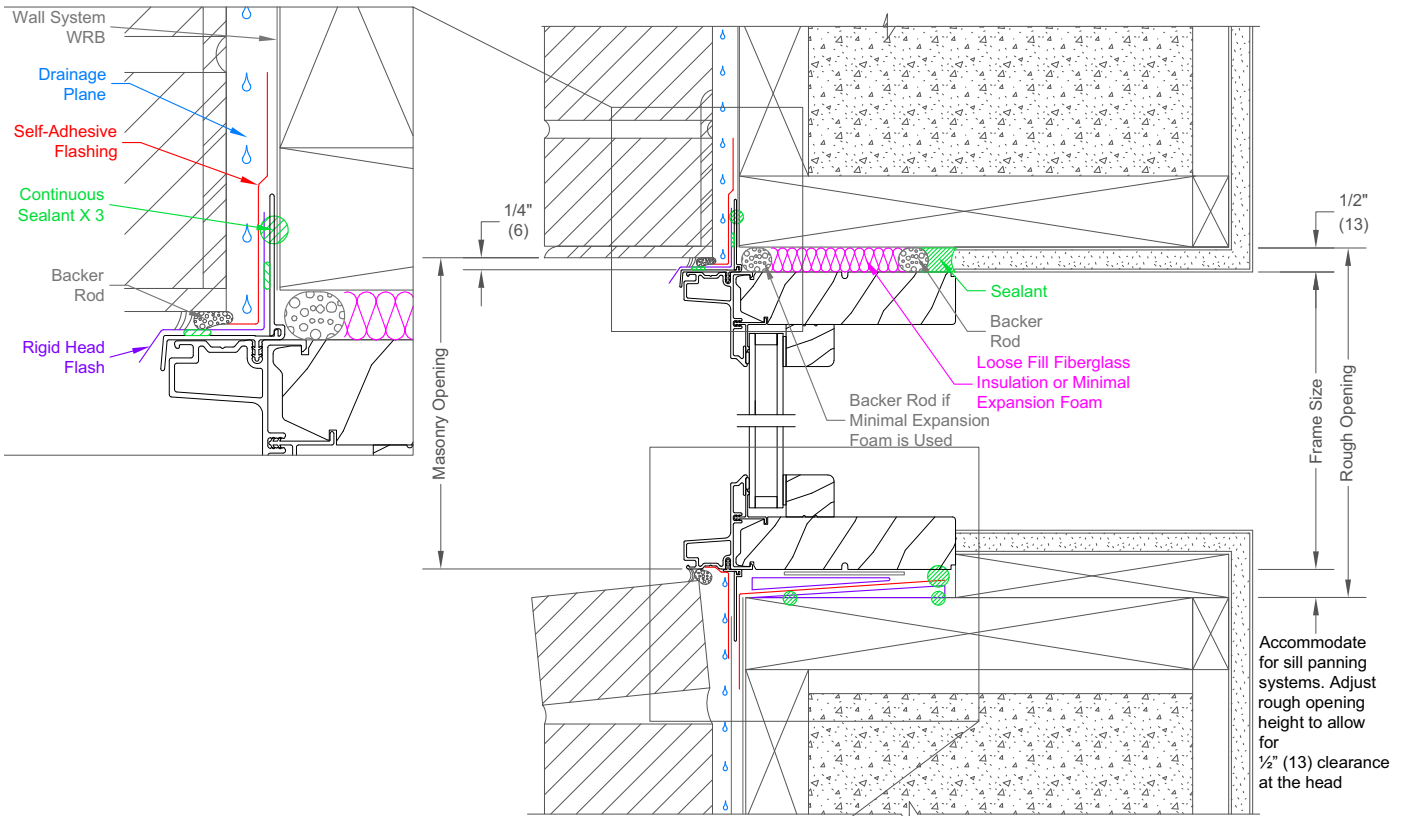

**Head Jamb and Sill**

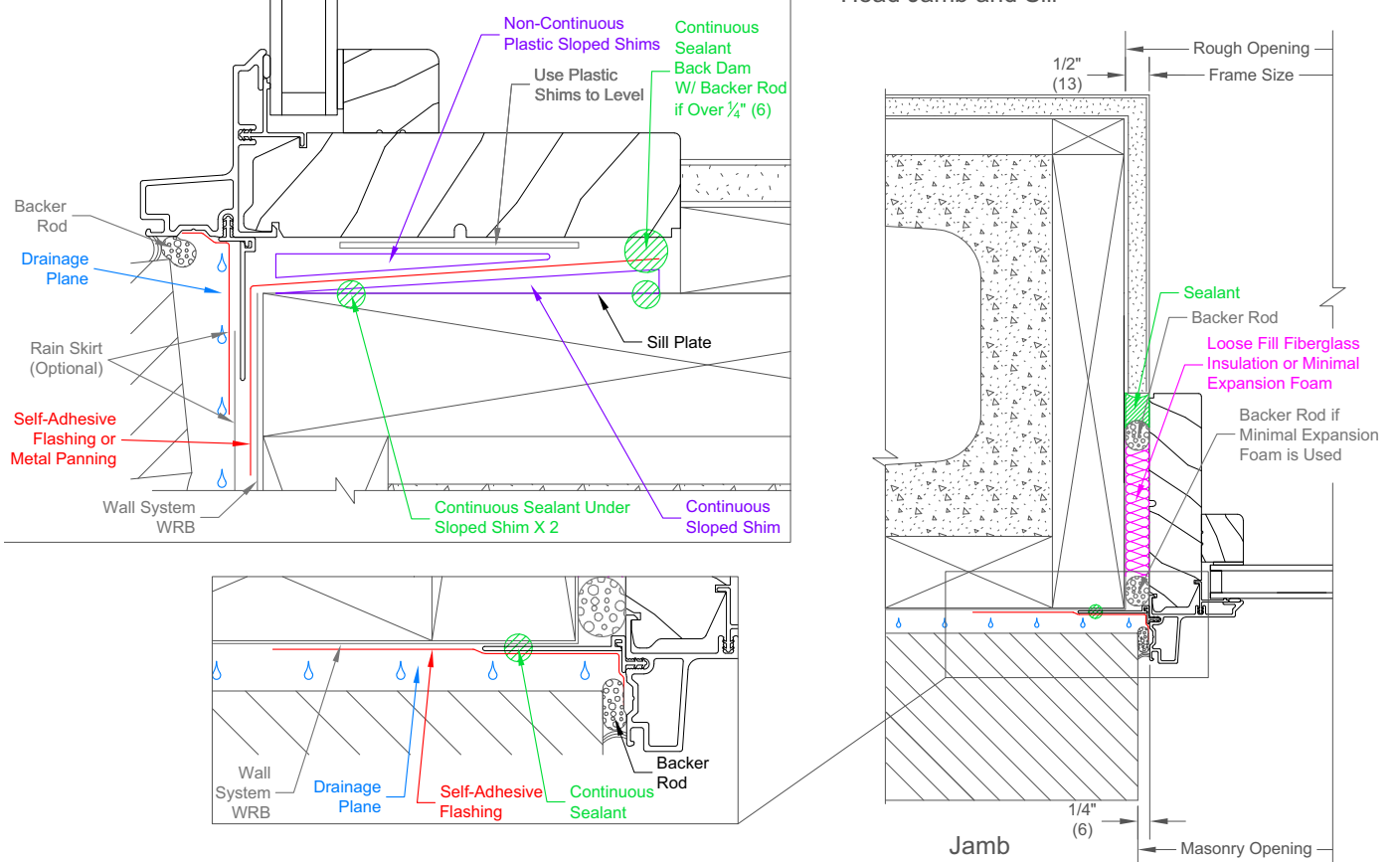

**Ultimate Wood Direct Glaze Polygon - Concrete Block with Brick Veneer**

Scale: 3" = 1'0"

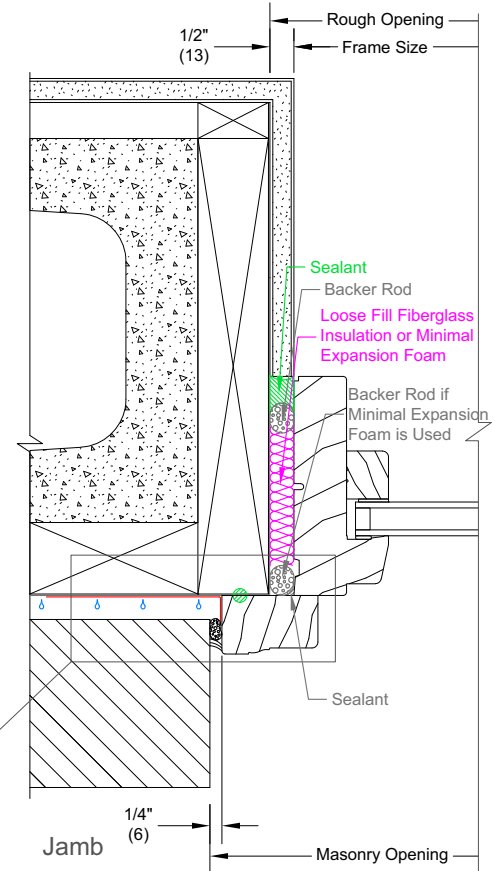
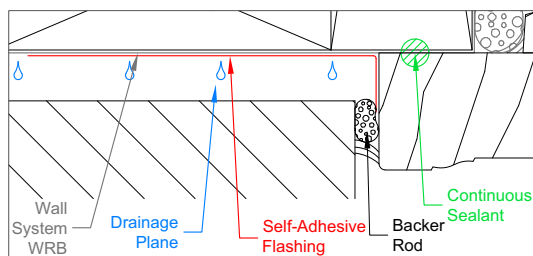
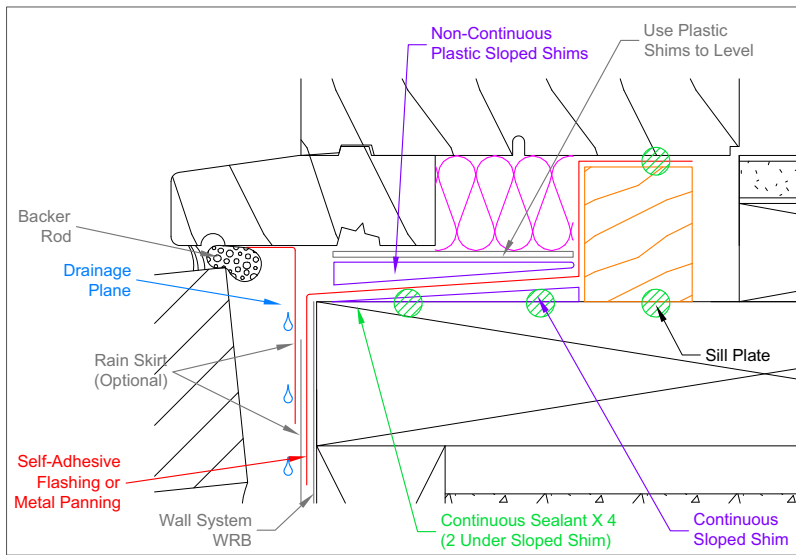
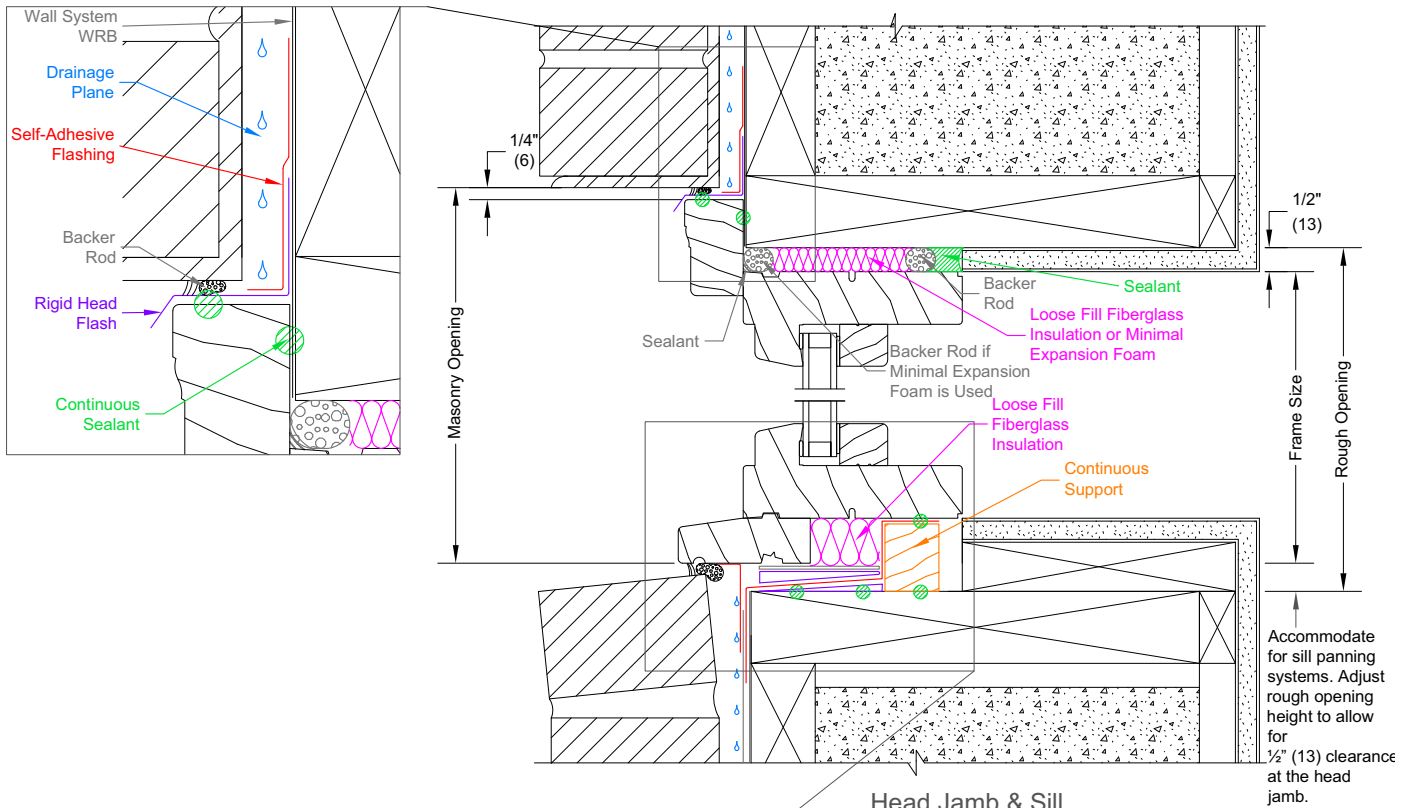

**Ultimate Direct Glaze Poly - Wood Siding Combination Wall Sheathing, WRB and Air Barrier**

Scale: 3" = 1'0"

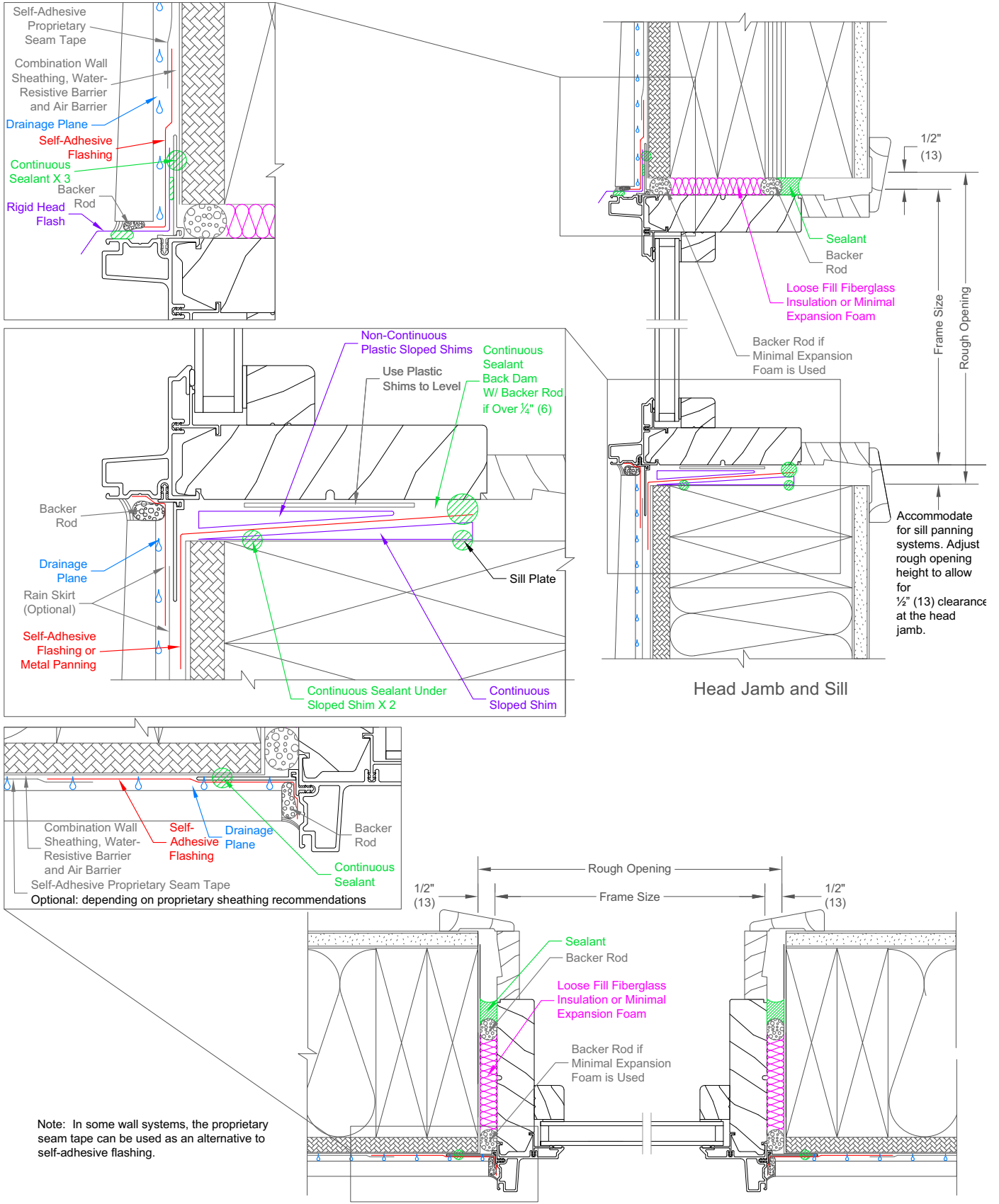

**Ultimate Direct Glaze Polygon - Foam Plastic Insulated Sheathing (FPIS) over WRB**

Scale: 3" = 1'0"

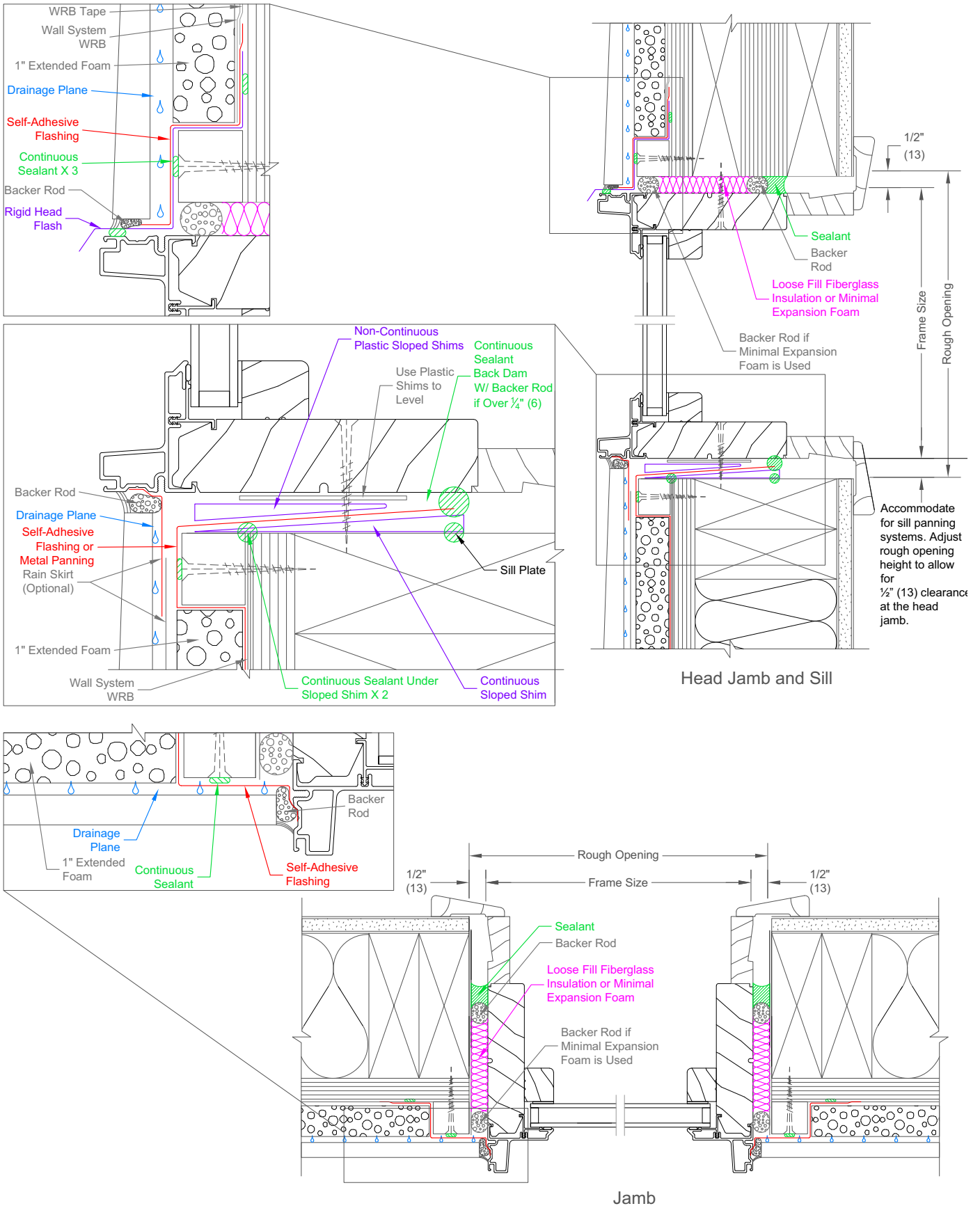

Head Jamb and Sill

Jamb

**Ultimate Wood Direct Glaze Polygon - Foam Plastic Insulated (FPIS) under WRB**

Scale: 3" = 1'0"

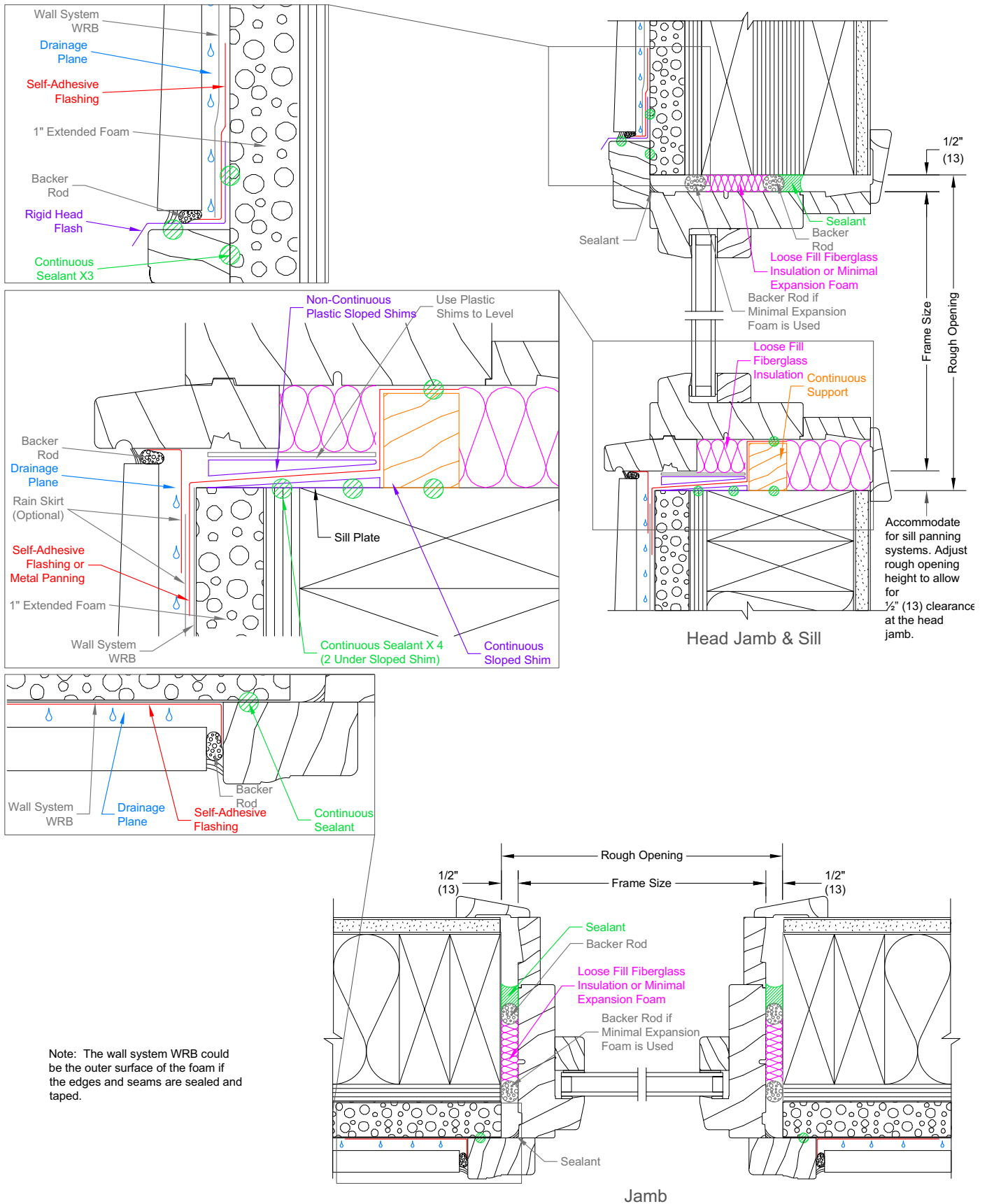

Note: The wall system WRB could be the outer surface of the foam if the edges and seams are sealed and taped.

Ultimate Inswing French Door - Frame with Steel Siding

Scale: 3" = 1"0"

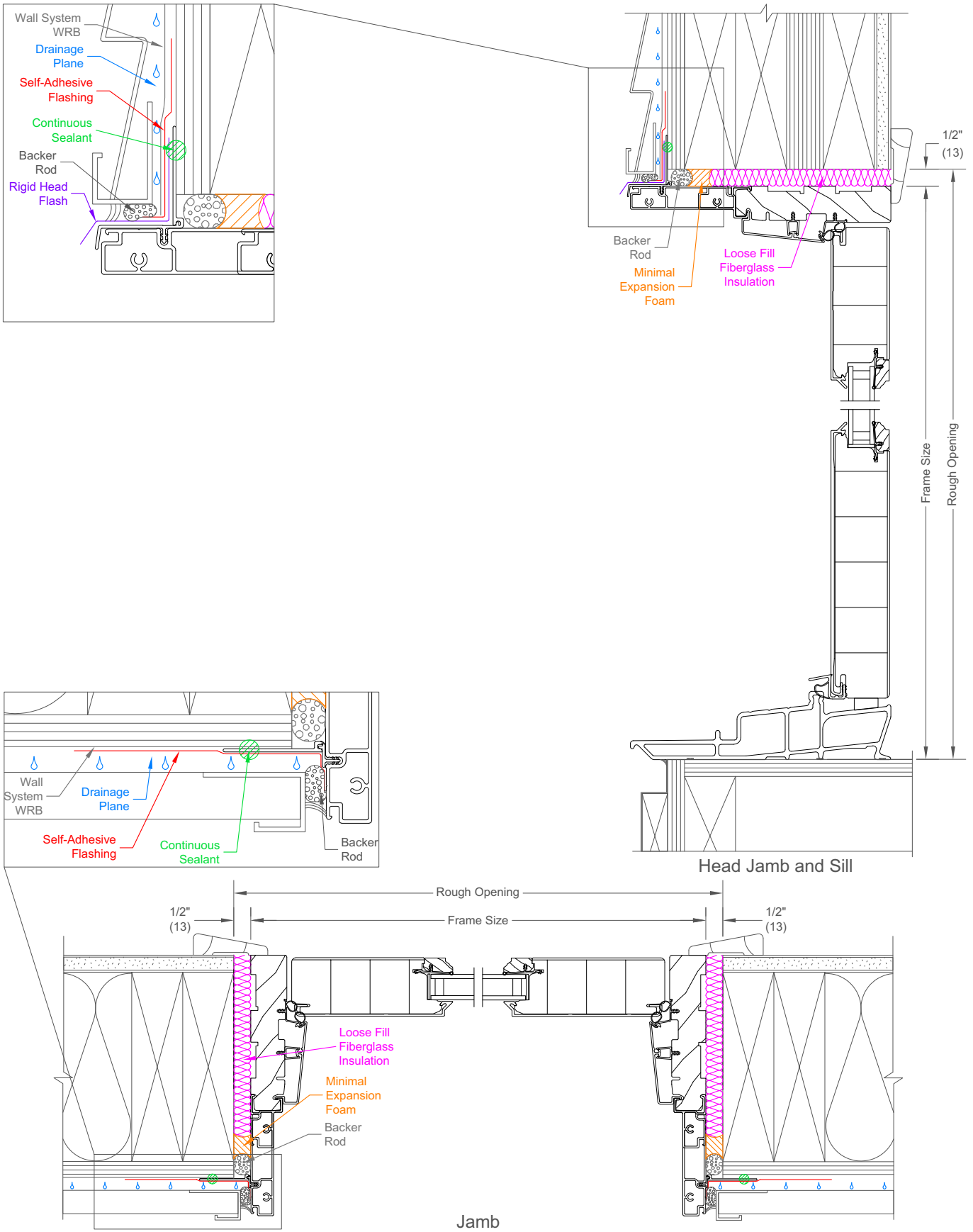

Ultimate Wood Inswing French Door - 2x6 Frame with Steel Siding

Scale: 3" = 1'0"

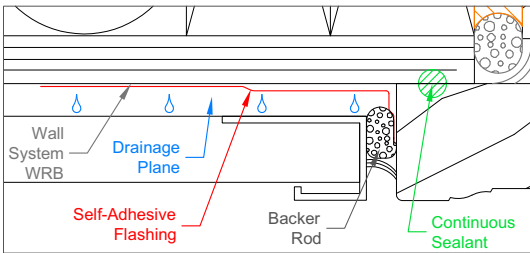
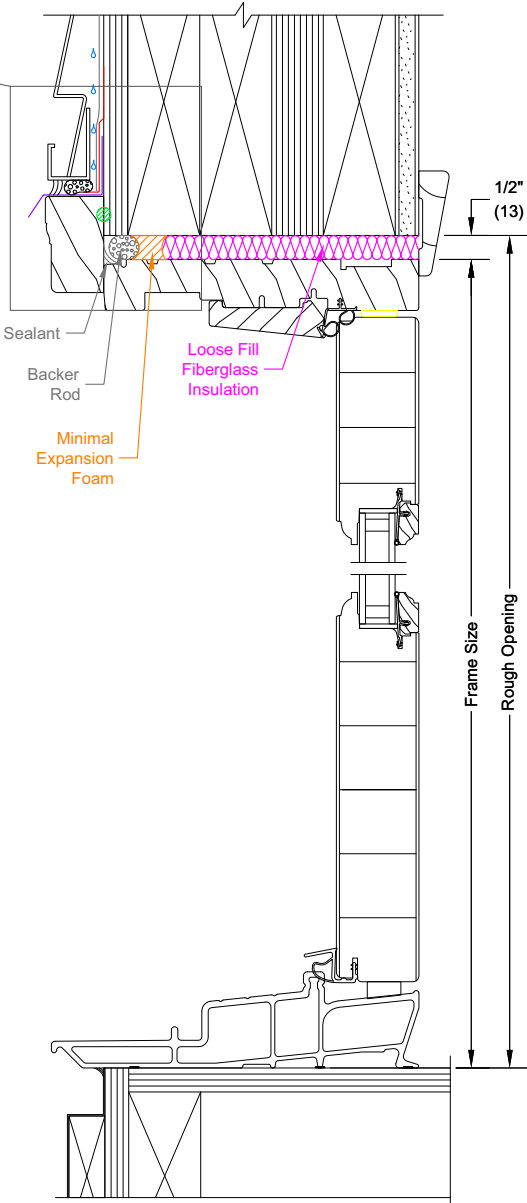
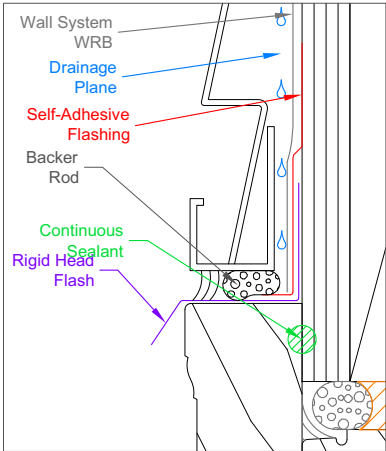

Head Jamb and Sill

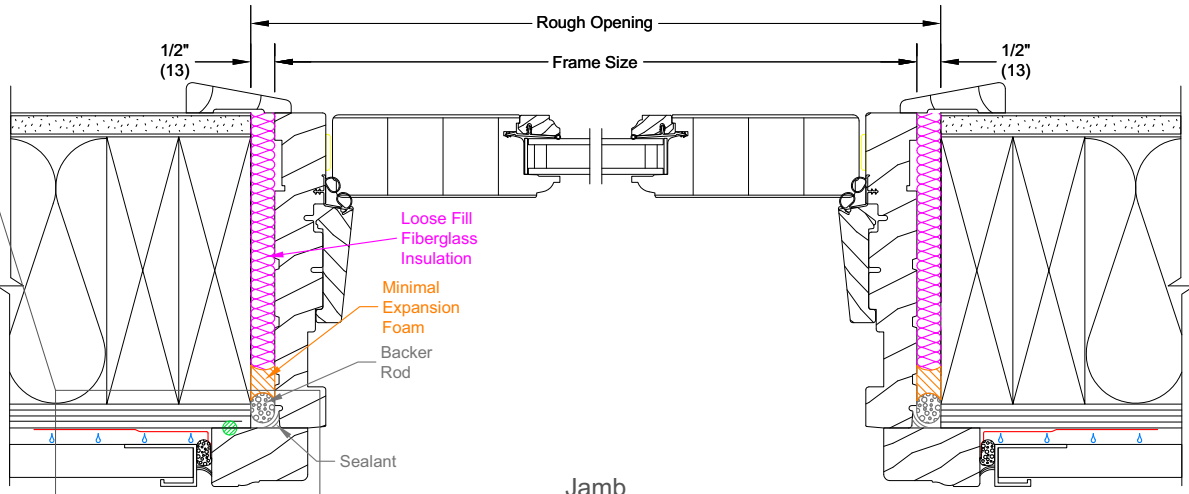

Jamb



**Structural Support Options**

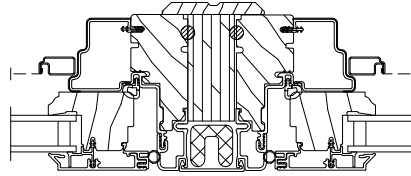

LVL Vertical Mullion

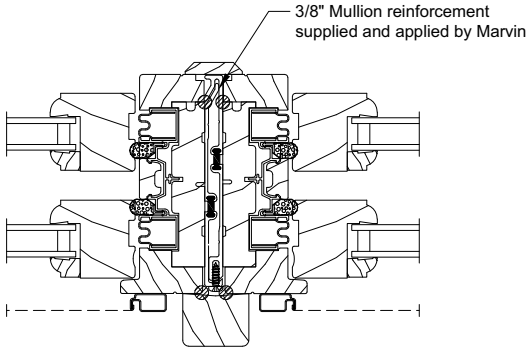

3/8" Vertical Mullion

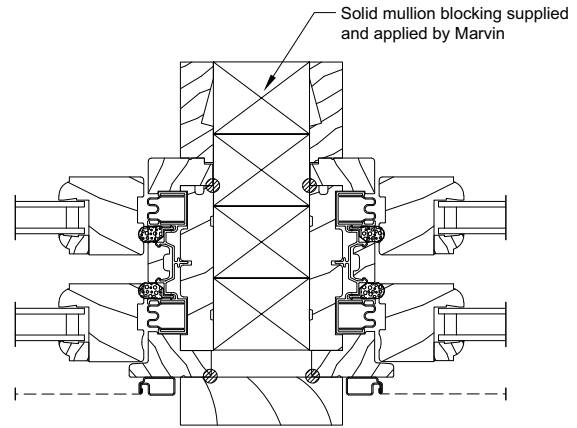



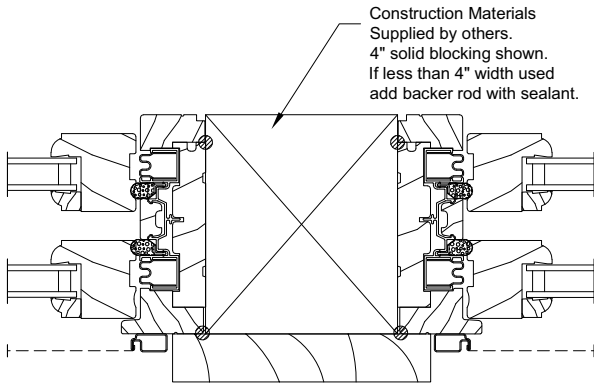

Solid Wood blocking Vertical Mullion

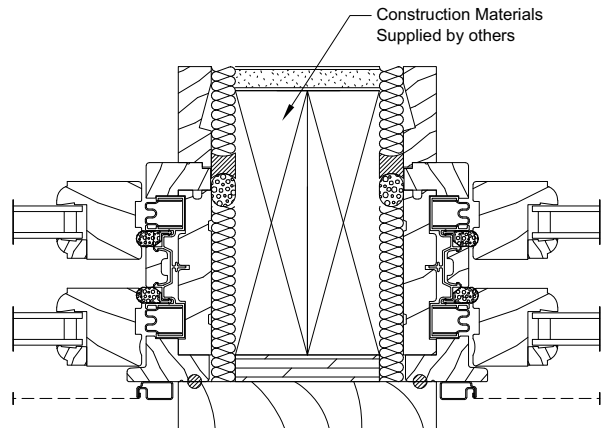

4" Space Vertical Mullion detail  
With 4 9/16" Jamba



4" Stud Pocket mullion detail  
With 6 9/16" Jamba

-  Continuous Sealant
-  Loose Fill Fiberglass
-  Insulation
-  Backer Rod
-  Adhesive Flash

*NOTE: For structural support options, please contact your Marvin representative*

**Modern Casement - 2x6 Frame with Stucco**

Scale: 3" = 1'0"

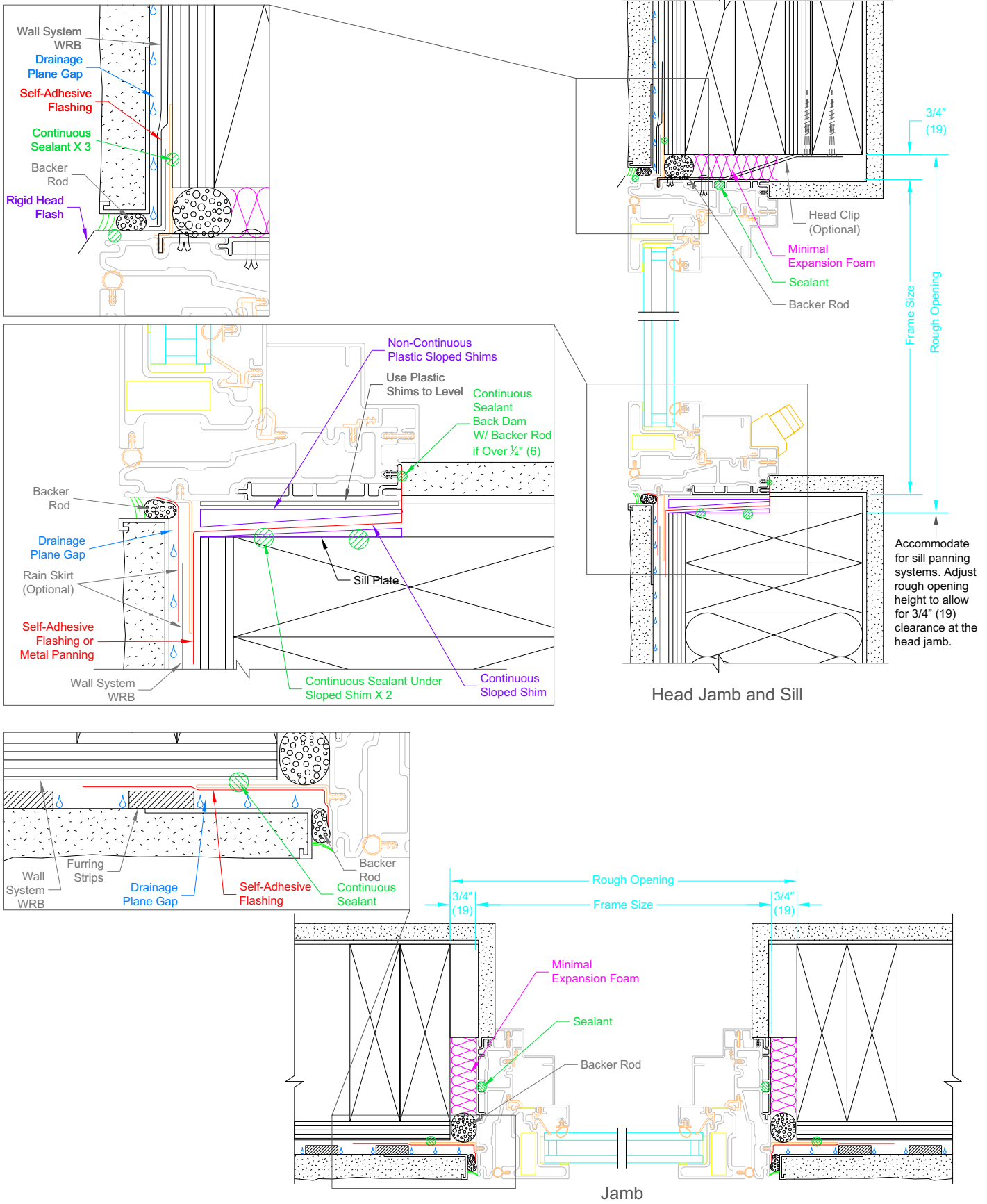

**Modern Casement - 2x6 Frame with Wall Sheathing**

Scale: 3" = 1'0"

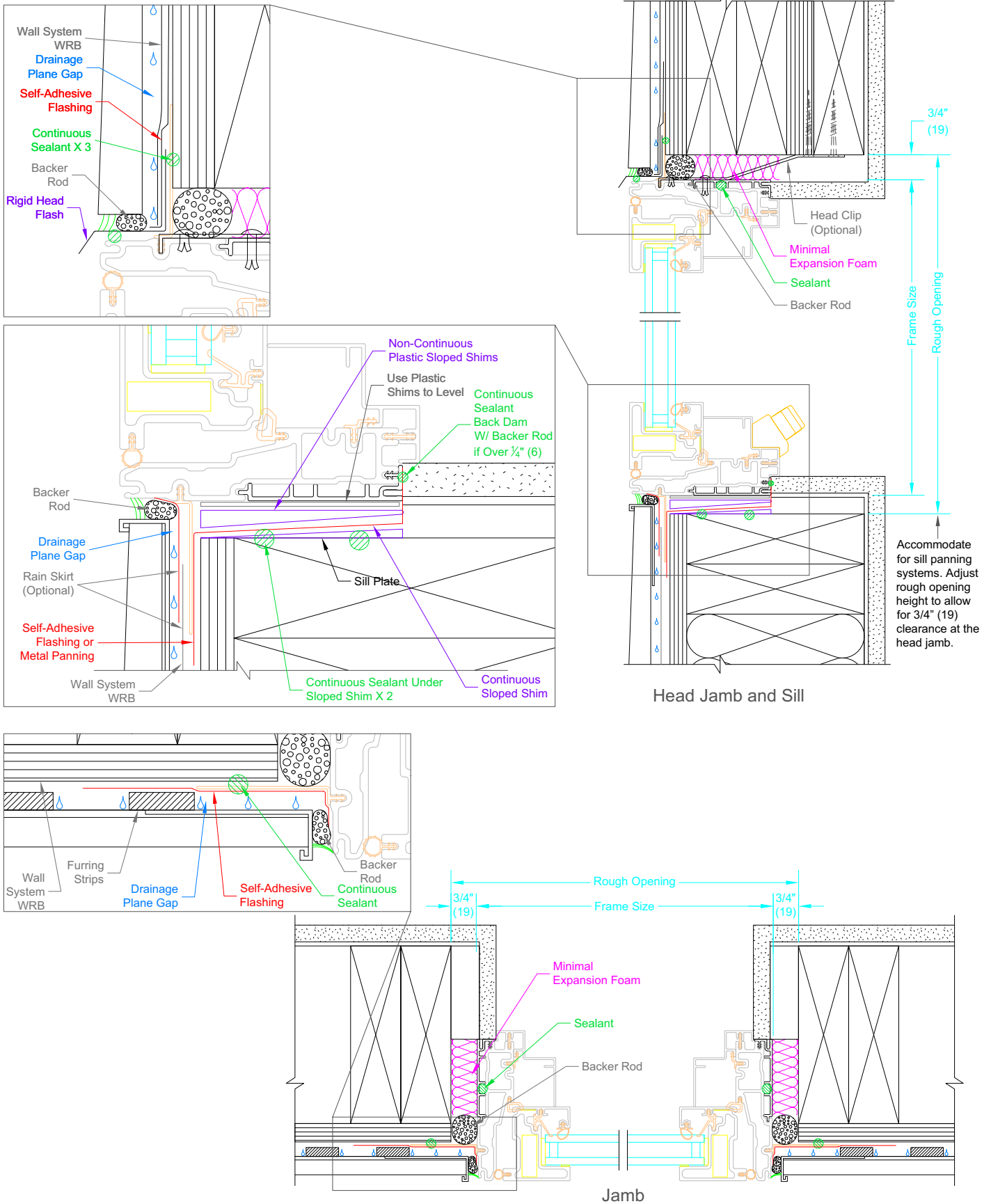

Head Jamb and Sill

Jamb