

**Jennifer Ross**

**From:** josh dinverno <joshdinverno@yahoo.com>  
**Sent:** Saturday, April 30, 2022 11:21 PM  
**To:** Brendan Cagney; Jennifer Ross  
**Cc:** Historic District Commission (Staff)  
**Subject:** [EXTERNAL]Re: [EXTERNAL]Re: [EXTERNAL]Re: HDC 5/11/22 MEETING UPDATE: 1310 labrosse

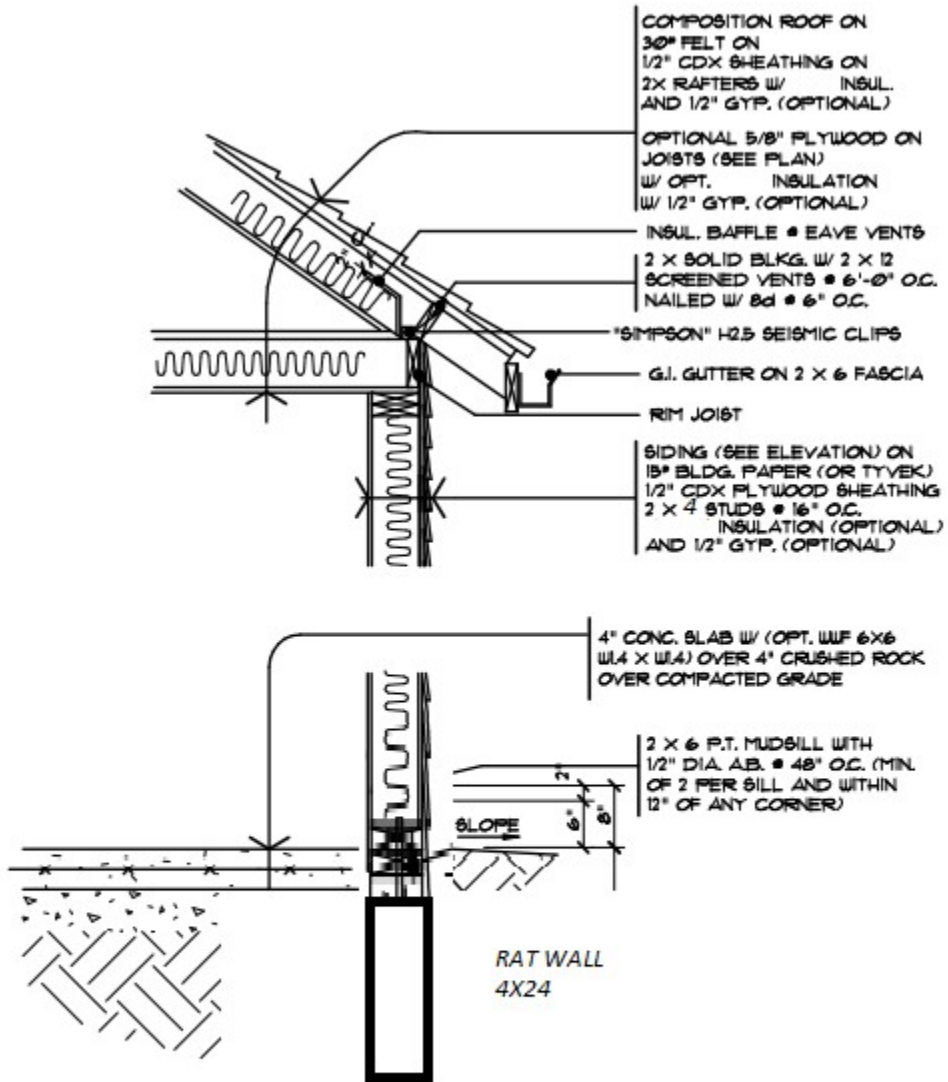

TYPICAL WALL SECTION  
(FRAMED ROOF) NOT TO SCALE

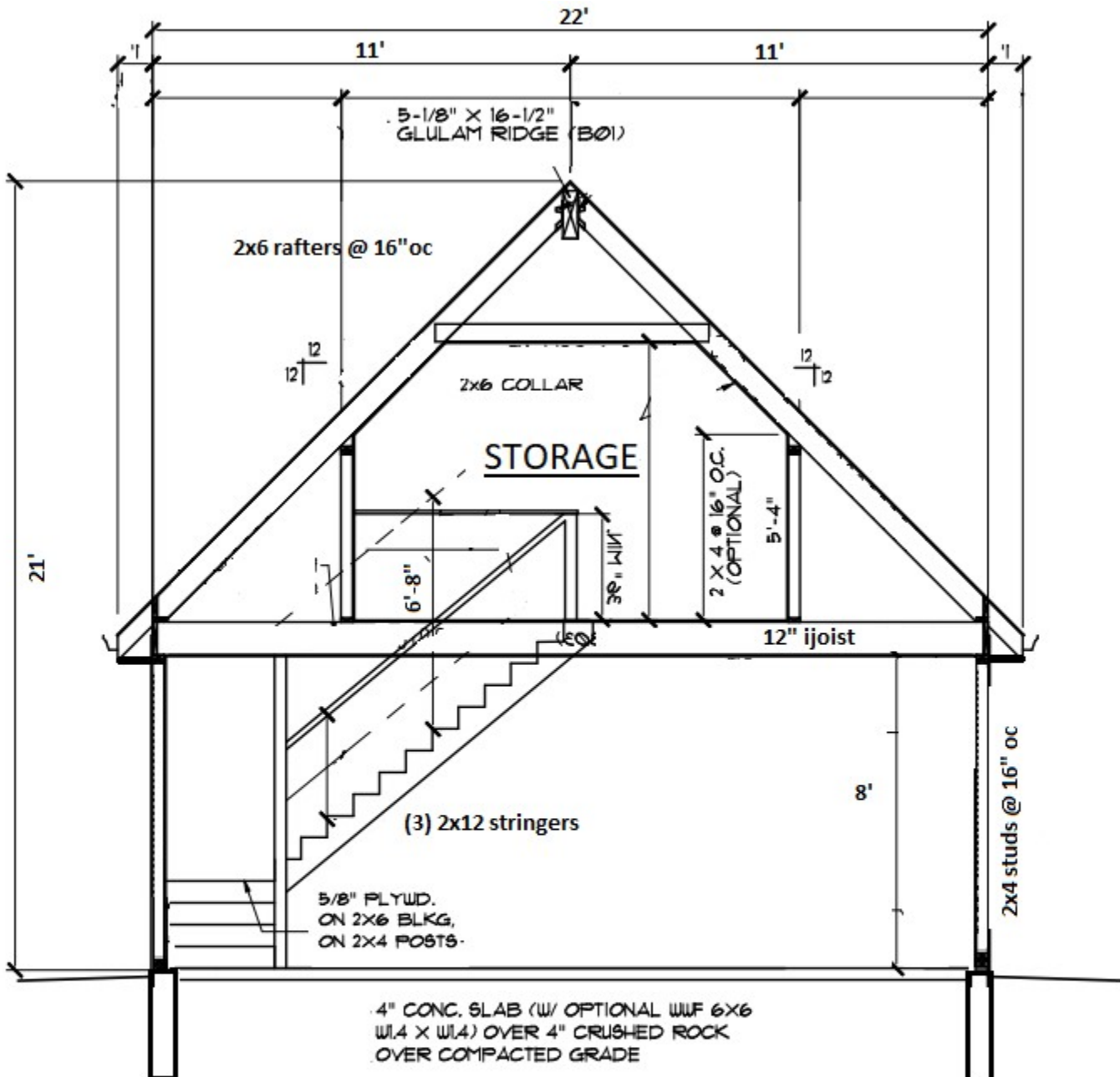

**NOTE:**  
 OPTIONAL TRUSSES  
 MAY BE USED. THIS WILL  
 ELIMINATE THE GLULAM RIDGE,  
 RAFTERS, JOISTS,  
 BEAMS, POSTS, AND  
 THE GLULAM FOOTINGS.  
 TRUSS SPECIFICATIONS  
 ARE PROVIDED BY OTHERS.

4X24" RAT WALL

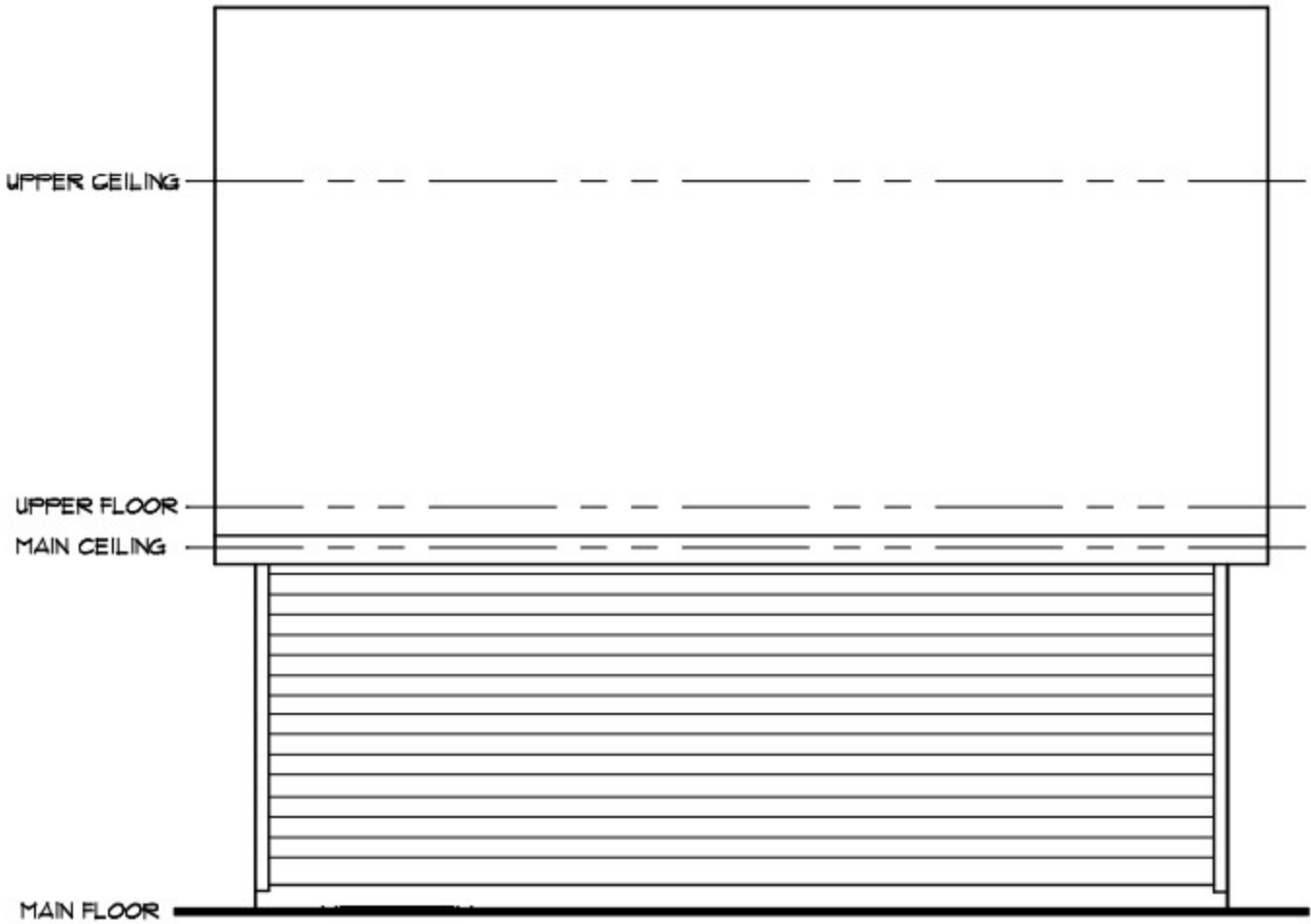

RIGHT ELEVATION

1/4" = 1'-0"

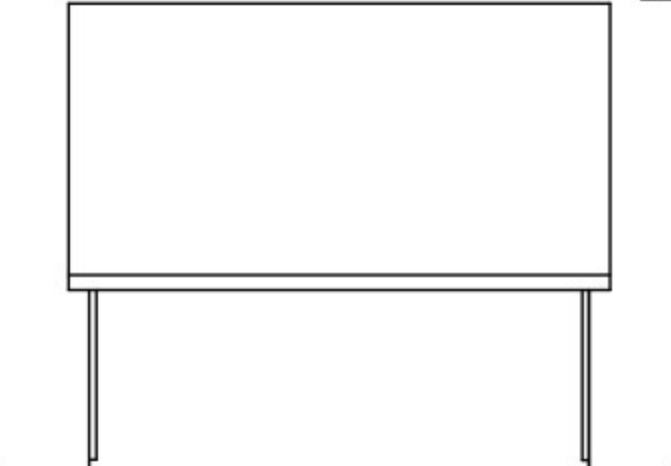

LEFT ELEVATION

1/8" = 1'-0"

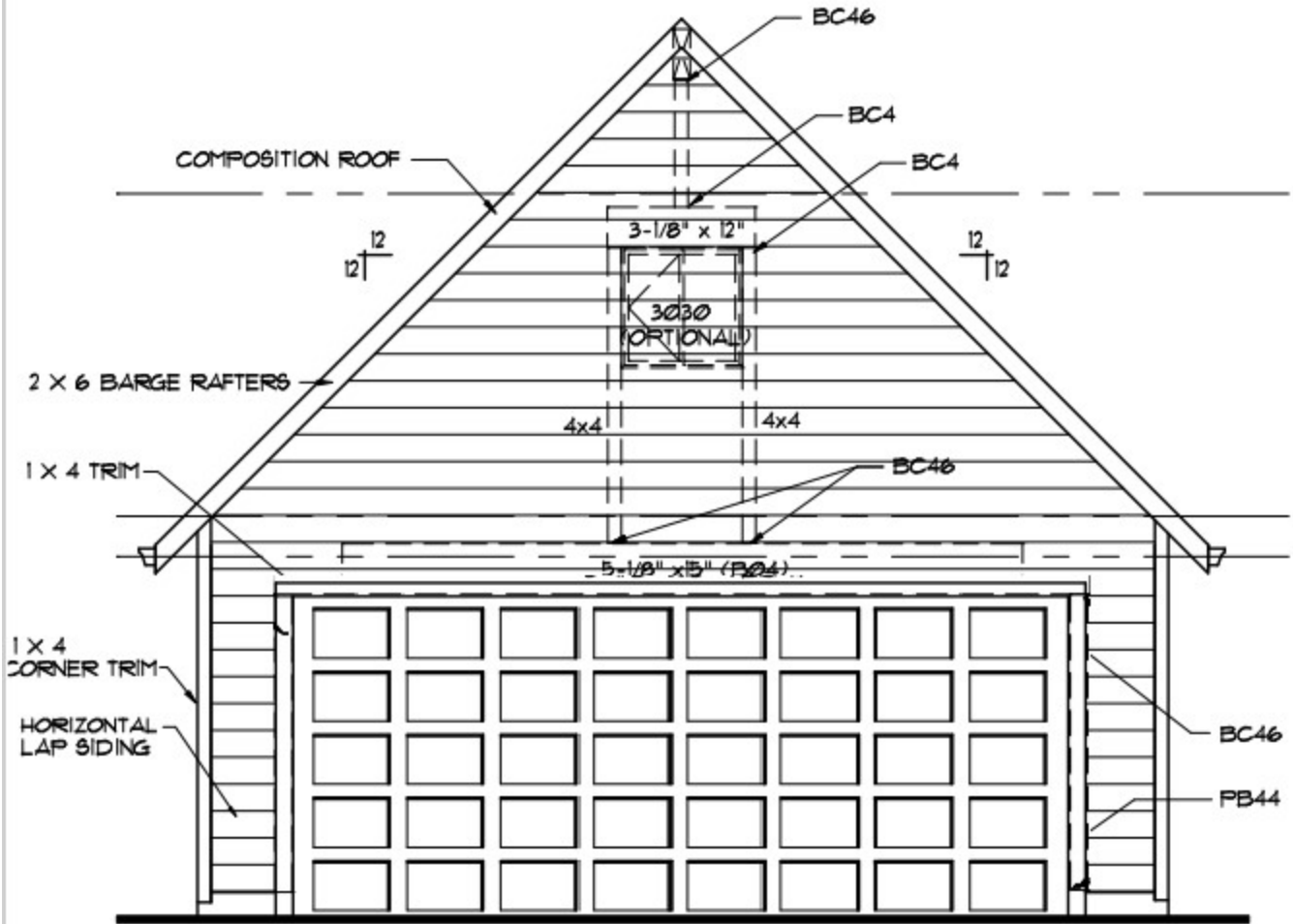

**FRONT ELEVATION**

1/4" = 1'-0"

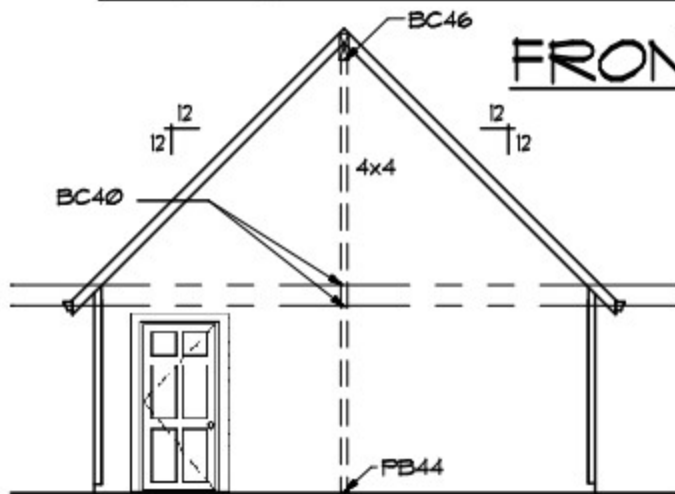

**REAR ELEVATION**

1/8" = 1'-0"

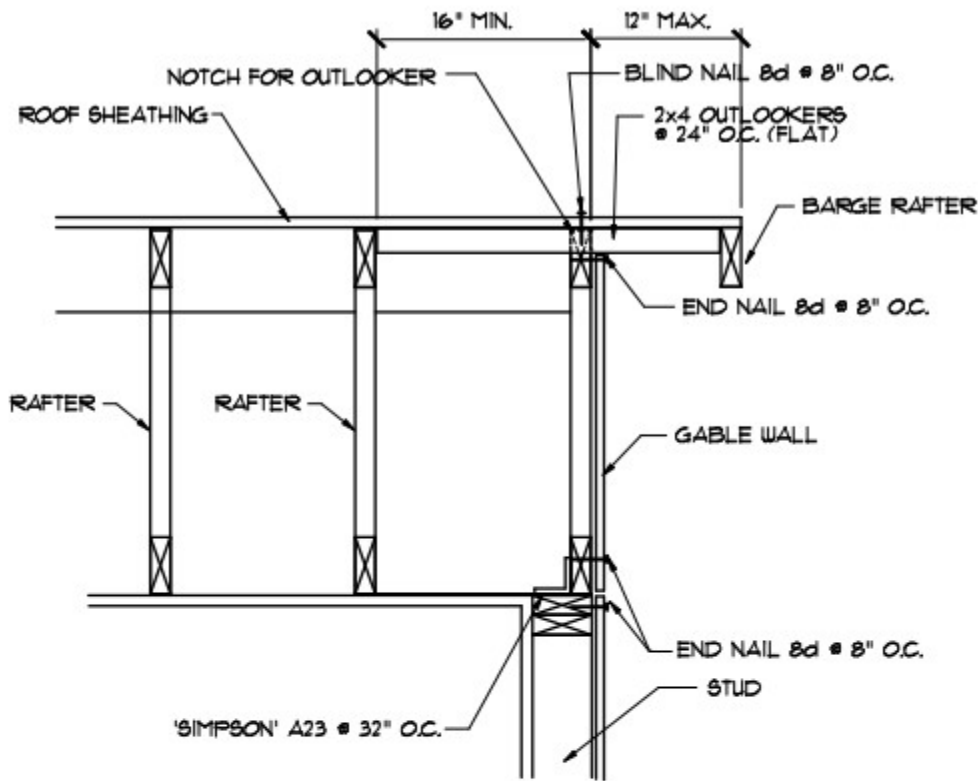

**GABLE END DETAIL**  
 (FRAMED ROOF) AT 6'-0" O.C.

**GENERAL NOTES**

1. ALL WORK SHALL COMPLY WITH THE RESIDENTIAL CODE (2009 EDITION), STATE CODES OR AMENDMENTS, LOCAL CODES AND REGULATIONS.
2. THE CONTRACTOR IS RESPONSIBLE AND IS TO NOTIFY THE DESIGNER OF OMISSIONS PRIOR TO THE START OF WORK.
3. WRITTEN DIMENSIONS HAVE PRECEDENCE OVER DIMENSIONS. DO NOT SCALE THE DRAWING.
4. ROOF VENTS TO TOTAL MORE THAN 1% OF ATTIC AREA BEING VENTILATED.

**STAIR DETAIL**

MIN. 3' WIDE 2X10 TREADS  
 1.5" RISE ON 2X12 STRINGERS  
 ON 4X4 P.T. POSTS ON  
 METAL BRACKETS ON  
 16" X 18" DP. CONC.

PLATFORM MIN. 3' WIDE  
 2X6 JOISTS @ 16" O.C.  
 4X4 P.T. POSTS ON  
 METAL BRACKETS ON  
 16" X 18" DP. CONC.

On Thursday, April 28, 2022, 04:08:43 PM EDT, josh dinverno <joshdinverno@yahoo.com> wrote:

DINVERNO  
REMODELING AND CONSTRUCTION

ARTURO QUIROZ

1310 LABROSSE STREET, DETROIT,  
MICHIGAN, 48226, UNITED STATES

DRAWING BY JOSH DINVERNO

DATE  
4/7/2022

SCALE 1/4" = 1'

HEADERS  
4' = DBL 2X6  
8' = DBL 2X8  
12' = DBL 2X10  
16' = DBL 2X12

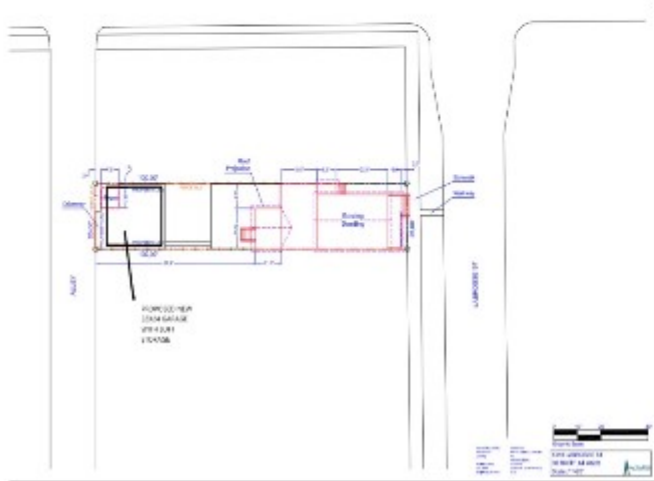
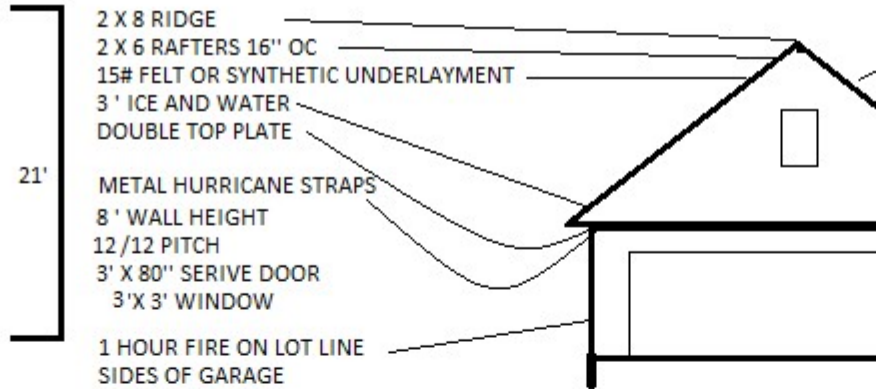
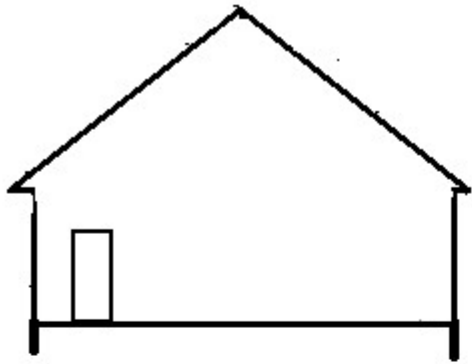
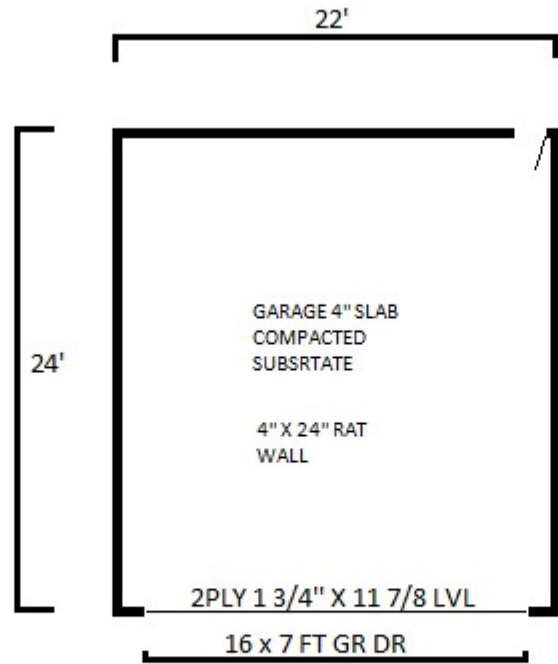

On Thursday, April 28, 2022, 01:42:09 PM EDT, Jennifer Ross <rossj@detroitmi.gov> wrote:

Hello Mr. Diverno,

Thanks for the additional information. Please note that the Director of the Historic District Commission reviewed the garage elevations and has requested that your team provide additional detail to the renderings. Please see the attached go by as a guide to the level of detail which you must add to the elevation drawings (all four elevations). I will need to have the staff report for this project completed by next Weds, May 4, 2022. I will therefore need your revised elevation drawings by Tuesday May 3, 5:00PM. Please feel free to email with any questions.

Sincerely,

Jennifer

---

**From:** josh dinverno <joshdinverno@yahoo.com>  
**Sent:** Tuesday, April 26, 2022 5:30 PM  
**To:** Brendan Cagney <cagneyb@detroitmi.gov>; Jennifer Ross <rossj@detroitmi.gov>  
**Cc:** Historic District Commission (Staff) <hdc@detroitmi.gov>  
**Subject:** [EXTERNAL]Re: [EXTERNAL]Re: HDC 5/11/22 MEETING UPDATE: 1310 labrosse

Rear Elevation

Side Elev

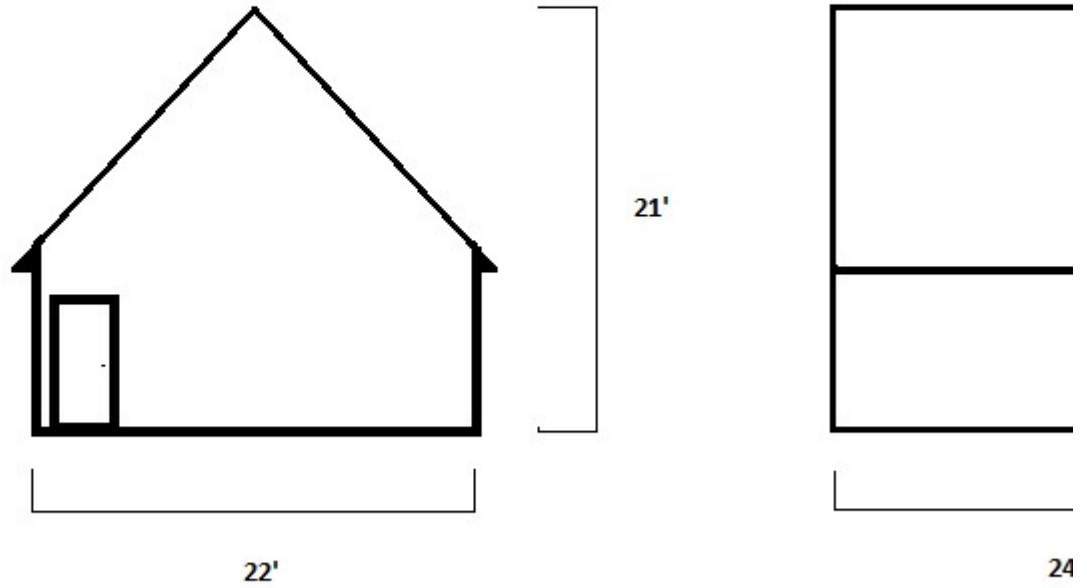

On Tuesday, April 26, 2022, 05:24:00 PM EDT, josh dinverno <[joshdinverno@yahoo.com](mailto:joshdinverno@yahoo.com)> wrote:

side and rear elevations

On Tuesday, April 26, 2022, 01:21:34 PM EDT, Jennifer Ross <[rossj@detroitmi.gov](mailto:rossj@detroitmi.gov)> wrote:

Hello Mr. Dinverno,

Thanks so much for your application. After an initial review of the email which I received today (April 26, 2022, 12:44 PM) I have noted that the following info is outstanding/needs to be submitted in order to secure your spot on the May 11 meeting agenda:

-dimensioned drawings of the side and rear elevations of the proposed new garage

The application graphics that have been submitted thus far only include an elevation drawing of the front elevation and the floor plan. The application requires the same dimensioned drawing of all elevations, therefore you must provide that info for the side and rear walls. As of now, your application is incomplete.

As previously noted, please feel free to send the above-listed info to me before 5:00PM tomorrow (4/27/2022) if you wish to retain your spot on the upcoming/May 2022 agenda. If you need more time to pull together the outstanding elevation drawings/if you



need more time, the case can be moved to the June 2022 Historic District Commission meeting. Feel free to let me know if you have any questions.

Sincerely,  
Jennifer

---

**From:** josh dinverno <[joshdinverno@yahoo.com](mailto:joshdinverno@yahoo.com)>

**Sent:** Tuesday, April 26, 2022 12:44 PM

**To:** Brendan Cagney <[cagneyb@detroitmi.gov](mailto:cagneyb@detroitmi.gov)>; Jennifer Ross <[rossj@detroitmi.gov](mailto:rossj@detroitmi.gov)>

**Cc:** Historic District Commission (Staff) <[hdc@detroitmi.gov](mailto:hdc@detroitmi.gov)>

**Subject:** [EXTERNAL]Re: HDC 5/11/22 MEETING UPDATE: 1310 labrosse

side elevations &  
window size

DINVERNO  
REMODELING AND CONSTRUCTION

ARTURO QUIROZ

1310 LABROSSE STREET, DETROIT,  
MICHIGAN, 48226, UNITED STATES

DRAWING BY JOSH DINVERNO

DATE  
4/7/2022

SCALE 1/4" = 1'

HEADERS  
4' = DBL 2X6  
8' = DBL 2X8  
12' = DBL 2X10  
16' = DBL 2X12

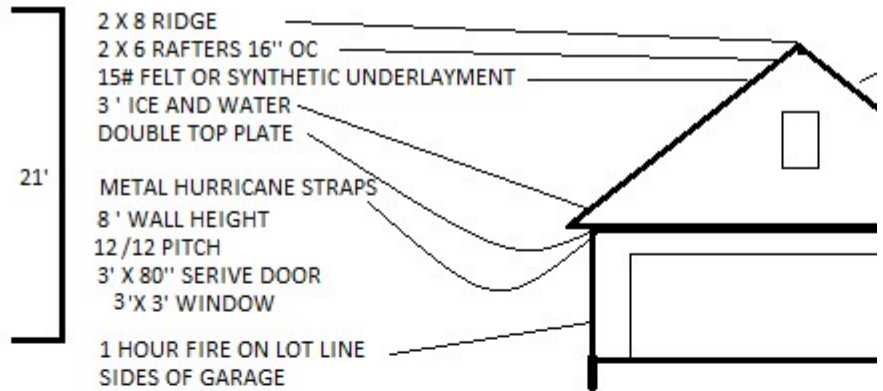
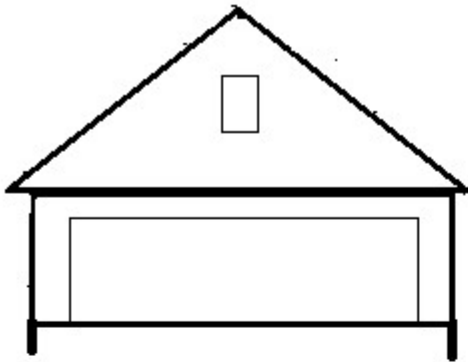
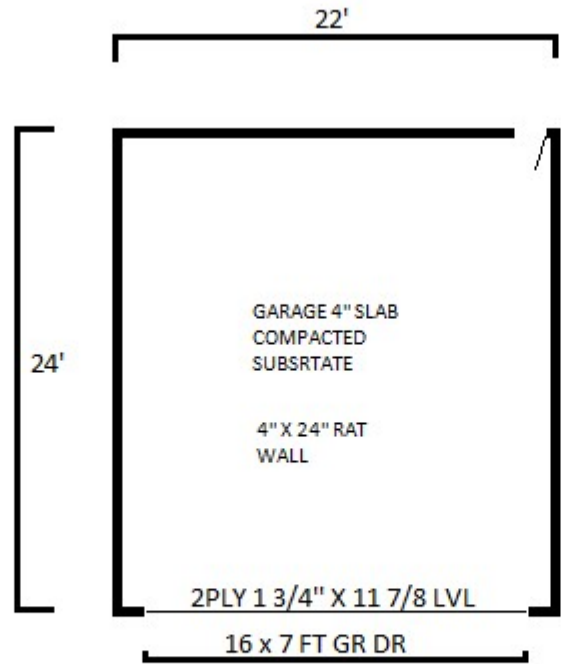

DINVERNO  
REMODELING AND CONSTRUCTION

ARTURO QUIROZ

1310 LABROSSE STREET, DETROIT,  
MICHIGAN, 48226, UNITED STATES

DRAWING BY JOSH DINVERNO

DATE  
4/7/2022

SCALE 1/4" = 1'

HEADERS  
4' = DBL 2X6  
8' = DBL 2X8  
12' = DBL 2X10  
16' = DBL 2X12

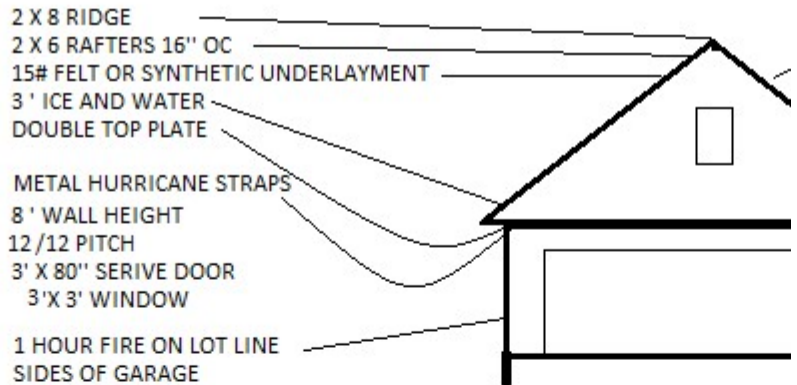
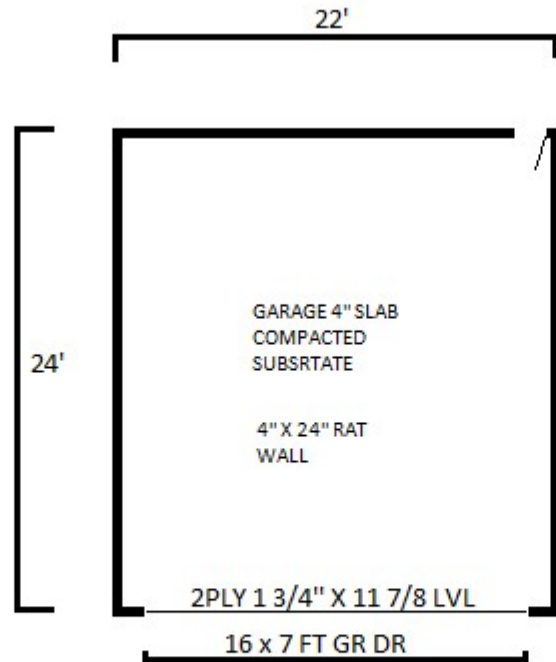

On Thursday, April 21, 2022, 02:35:42 PM EDT, Jennifer Ross <[rossj@detroitmi.gov](mailto:rossj@detroitmi.gov)> wrote:

Hello Mr. Dinverno,

Thanks so much for your application. After an initial review for completeness I have noted that the following info is outstanding/needs to be submitted in order to secure your spot on the May 11 meeting agenda:

- dimensioned drawings of the side and rear elevations of the proposed new garage
- dimensions re: the window opening in the front elevation gable end

Please feel free to send the above-listed info to me by next Weds (4/27/2022) if you wish to retain your spot on the upcoming agenda. Feel free to let me know if you have any questions/concerns.

Sincerely,

Jennifer

---

**From:** Brendan Cagney <[cagneyb@detroitmi.gov](mailto:cagneyb@detroitmi.gov)>  
**Sent:** Thursday, April 21, 2022 12:54 PM  
**To:** 'josh dinverno' <[joshdinverno@yahoo.com](mailto:joshdinverno@yahoo.com)>  
**Cc:** Jennifer Ross <[rossj@detroitmi.gov](mailto:rossj@detroitmi.gov)>; Historic District Commission (Staff) <[hdc@detroitmi.gov](mailto:hdc@detroitmi.gov)>  
**Subject:** HDC 5/11/22 MEETING UPDATE: 1310 labrosse

Good Afternoon,

Your application will be heard at the next available Historic District Commission meeting, on **5-11-2022 at 5:30 p.m.**

The Detroit Historic District Commission will be meeting **in person at the Coleman A. Young Municipal Center (2 Woodward) on Wednesday, May 11, 2022, at 5:30 p.m.** for the Regular Meeting.

**Because of COVID-19 restrictions, this meeting will be held electronically and is open to the public. Virtual public attendance is strongly encouraged** as, pursuant to public health guidelines, the meeting room will be subject to space limitations, and there are limited additional opportunities for public viewing within the building. For the safety of attendees and participants, it is recommended that the public participate electronically via one of the following two means:

- **Zoom Meeting Link:** <https://cityofdetroit.zoom.us/j/532007617>
- **By Phone:** 312-626-6799 (Meeting ID # 532007617)

You will receive additional details as the meeting date approaches.

**Going forward with your application, my colleague, Jennifer Ross, who is cc'd on this email, will be your primary HDC contact.**

Upon an initial review of the submitted materials, she may need to schedule a phone call with you to introduce herself and to answer any immediate questions.

Any information about your project proposal conveyed to me/staff through conversations in the office, on the phone or in email, should be captured in writing in a separate document and submitted by you as part of your application. Also, as staff prepares your report, please be prepared to clarify specific details of your application, or to supply additional information, if requested. **If you feel there is additional information the Commission should consider, or HDC staff has requested additional information to supplement your application, please submit this as a separate document.**

The staff report is typically available the Monday prior to the Wednesday meeting and may contain a staff recommendation to the Commission. It will be posted to the HDC website along with all submitted documents and photographs. Staff will notify you by email when the staff report is available. **It is imperative you read the staff report completely prior to the meeting.**

Sincerely,

**Brendan Cagney**

Staff, Historic Preservation | Planning & Development | City of Detroit  
Coleman A. Young Municipal Center, 2 Woodward Ave. Suite 808, Detroit, MI 48226

[www.detroitmi.gov/pdd](http://www.detroitmi.gov/pdd)

[cagneyb@detroitmi.gov](mailto:cagneyb@detroitmi.gov)

**Michael E. Duggan, Mayor**

**In order to ensure your safety and ours during the COV-ID 19 pandemic, we will be working remotely until further notice.**

---

**From:** josh dinverno <[joshdinverno@yahoo.com](mailto:joshdinverno@yahoo.com)>

**Sent:** Thursday, April 14, 2022 3:55 PM

**To:** Brendan Cagney <[cagneyb@detroitmi.gov](mailto:cagneyb@detroitmi.gov)>

**Subject:** [EXTERNAL]Re: [EXTERNAL]garage build1310 labrosse, detroit, 48226

just wanted to make sure you have everything you need?

On Thursday, April 14, 2022, 11:42:49 AM EDT, josh dinverno <[joshdinverno@yahoo.com](mailto:joshdinverno@yahoo.com)> wrote:

**1 .Provide current**

On Thursday, April 14, 2022, 09:46:20 AM EDT, Historic District Commission (Staff) <[hdc@detroitmi.gov](mailto:hdc@detroitmi.gov)> wrote:

Ok it is important to note to the applicants, the application is not complete until I receive all of the required information.

See previous message to make sure you have everything sent to me by Monday.

Sincerely,

**Brendan Cagney**

Staff, Historic Preservation | Planning & Development | City of Detroit  
Coleman A. Young Municipal Center, 2 Woodward Ave. Suite 808, Detroit, MI 48226

[www.detroitmi.gov/pdd](http://www.detroitmi.gov/pdd)

[cagneyb@detroitmi.gov](mailto:cagneyb@detroitmi.gov)

**Michael E. Duggan, Mayor**

**In order to ensure your safety and ours during the COV-ID 19 pandemic, we will be working remotely until further notice.**

---

**From:** Alycia Berry <[berryal@detroitmi.gov](mailto:berryal@detroitmi.gov)>

**Sent:** Thursday, April 14, 2022 9:44 AM

**To:** Historic District Commission (Staff) <[hdc@detroitmi.gov](mailto:hdc@detroitmi.gov)>; 'josh dinverno' <[joshdinverno@yahoo.com](mailto:joshdinverno@yahoo.com)>; Tim Dinverno Office <[timothydinvernodrc@gmail.com](mailto:timothydinvernodrc@gmail.com)>

**Subject:** Re: [EXTERNAL]garage build1310 labrosse, detroit, 48226

BLD2022-01835. It hasn't been sent to you guys yet. I will

Best Regards,  
**Alycia Berry**  
Information Technician  
Buildings, Safety Engineering& Environmental Department  
Plan Review Division  
Coleman A. Young Municipal Center  
2 Woodward Avenue, Suite 434  
Detroit, Michigan 48226  
Phone: (313) 224-0295

?

Received, thank you.Create reply with Received, thank you. Thank you!Create reply with Thank you! Got it, thanks!Create reply with Got it, thanks!

?

Are the suggestions above helpful?

---

**From:** Historic District Commission (Staff) <[hdc@detroitmi.gov](mailto:hdc@detroitmi.gov)>  
**Sent:** Thursday, April 14, 2022 9:42 AM  
**To:** Alycia Berry <[berryal@detroitmi.gov](mailto:berryal@detroitmi.gov)>; 'josh dinverno' <[joshdinverno@yahoo.com](mailto:joshdinverno@yahoo.com)>; Tim Dinverno Office <[timothydinvernodrc@gmail.com](mailto:timothydinvernodrc@gmail.com)>; Historic District Commission (Staff) <[hdc@detroitmi.gov](mailto:hdc@detroitmi.gov)>  
**Subject:** RE: [EXTERNAL]garage build1310 labrosse, detroit, 48226

Ok, what is the bld number?

**Sincerely,**

**Brendan Cagney**

Staff, Historic Preservation | Planning & Development | City of Detroit

Coleman A. Young Municipal Center, 2 Woodward Ave. Suite 808, Detroit, MI 48226

 [www.detroitmi.gov/pdd](http://www.detroitmi.gov/pdd)

 [cagneyb@detroitmi.gov](mailto:cagneyb@detroitmi.gov)

**Michael E. Duggan, Mayor**

**In order to ensure your safety and ours during the COV-ID 19 pandemic, we will be working remotely until further notice.**

---

**From:** Alycia Berry <[berryal@detroitmi.gov](mailto:berryal@detroitmi.gov)>

**Sent:** Thursday, April 14, 2022 9:34 AM

**To:** Brendan Cagney <[cagneyb@detroitmi.gov](mailto:cagneyb@detroitmi.gov)>; 'josh dinverno' <[joshdinverno@yahoo.com](mailto:joshdinverno@yahoo.com)>; Tim Dinverno Office <[timothydinvernodrc@gmail.com](mailto:timothydinvernodrc@gmail.com)>; Historic District Commission (Staff) <[hdc@detroitmi.gov](mailto:hdc@detroitmi.gov)>

**Subject:** Re: [EXTERNAL]garage build1310 labrosse, detroit, 48226

I have uploaded all the documents into the Historic Submission Folder in Projectdox.

Best Regards,

**Alycia Berry**

Information Technician  
Buildings, Safety Engineering& Environmental Department  
Plan Review Division  
Coleman A. Young Municipal Center  
2 Woodward Avenue, Suite 434  
Detroit, Michigan 48226  
Phone: (313) 224-0295

?

Received, thank you.Create reply with Received, thank you. Thank you!Create reply with Thank you! Got it, thanks!Create reply with Got it, thanks!

?

Are the suggestions above helpful?

---

**From:** Brendan Cagney <[cagneyb@detroitmi.gov](mailto:cagneyb@detroitmi.gov)>

**Sent:** Thursday, April 14, 2022 9:23 AM

**To:** 'josh dinverno' <[joshdinverno@yahoo.com](mailto:joshdinverno@yahoo.com)>; Tim Dinverno Office <[timothydinvernodrc@gmail.com](mailto:timothydinvernodrc@gmail.com)>; Alycia Berry <[berryal@detroitmi.gov](mailto:berryal@detroitmi.gov)>; Historic District Commission (Staff) <[hdc@detroitmi.gov](mailto:hdc@detroitmi.gov)>

**Subject:** RE: [EXTERNAL]garage build1310 labrosse, detroit, 48226

Good Morning,

Thanks for sending the information.

To complete your application, and get on the next available meeting, please send me the following information by Monday, 4-18-2022:

All HDC applications require the information on the first page of the linked Project Review Request form and a completed BSEED application (pages 2-3, all highlighted fields that apply, no notary required):

[https://detroitmi.gov/sites/detroitmi.localhost/files/forms/2021-07/01\\_HDC%20Project%20Review%20Request.pdf](https://detroitmi.gov/sites/detroitmi.localhost/files/forms/2021-07/01_HDC%20Project%20Review%20Request.pdf)

**Submit Photos - PDF or JPEG files:**

1 .Provide current, color photographs showing each full side of the building AND site– provide complete shots, as best as possible.

**Written info / Narrative for Commission - PDF or Word file:**

1. **Description of existing conditions** (including a brief explanation of existing materials and their current condition at location of proposed work)
2. **Description of project** (including an explanation as to why replacement –rather than repair- is required)
3. **Detailed scope of proposed work for approval** (formatted as bulleted list of all proposed exterior work to be approved and permitted) including, but not limited to:
  - the location, quantity and size of any exterior item that is proposed to be repaired, replaced, removed, built or installed

Sincerely,

**Brendan Cagney**

Staff, Historic Preservation | Planning & Development | City of Detroit

Coleman A. Young Municipal Center, 2 Woodward Ave. Suite 808, Detroit, MI 48226

 [www.detroitmi.gov/pdd](http://www.detroitmi.gov/pdd)

 [cagneyb@detroitmi.gov](mailto:cagneyb@detroitmi.gov)

**Michael E. Duggan, Mayor**

**In order to ensure your safety and ours during the COV-ID 19 pandemic, we will be working remotely until further notice.**

---

**From:** josh dinverno <[joshdinverno@yahoo.com](mailto:joshdinverno@yahoo.com)>

**Sent:** Wednesday, April 13, 2022 5:21 PM

**To:** Brendan Cagney <[cagneyb@detroitmi.gov](mailto:cagneyb@detroitmi.gov)>; Tim Dinverno Office <[timothydinvernodrc@gmail.com](mailto:timothydinvernodrc@gmail.com)>; Alycia Berry <[berryal@detroitmi.gov](mailto:berryal@detroitmi.gov)>; Historic District Commission (Staff) <[hdc@detroitmi.gov](mailto:hdc@detroitmi.gov)>

**Subject:** [EXTERNAL]garage build1310 labrosse, detroit, 48226



GARAGE TRIM COLOR IS NATUAL WHITE SW9542 EXTERIOR PAINT SHERWIN WILLIAMS SATIN SHEEN

ATTENTION: This email was sent from an external source. Please be extra cautious when opening attachments or clicking links.

ATTENTION: This email was sent from an external source. Please be extra cautious when opening attachments or clicking links.

ATTENTION: This email was sent from an external source. Please be extra cautious when opening attachments or clicking links.

ATTENTION: This email was sent from an external source. Please be extra cautious when opening attachments or clicking links.

ATTENTION: This email was sent from an external source. Please be extra cautious when opening attachments or clicking links.