

KAUL GLOVE BUILDINGS

DETROIT, MI

IMPORTANT NOTICES:

- The Client is responsible to verify accuracy on all dimensions and quantities on the submittal drawings.
- Approved or reviewed shop drawings will take precedence over specifications in case of a conflict.
- All elevations are as viewed from the exterior.
- These shop drawings are an interpretation of information which we have received in connection with this project. They may vary from the architectural drawings and/or field conditions and each detail must be thoroughly reviewed and approved by the architect. These shop drawings are supplied for the submittal and approval process. All parties involved shall review for respective applications.
- Prompt return of reviewed and approved drawing submittals is essential for expedient production scheduling for your order. Raw materials for your order will be ordered only upon receipt of approved submittal drawings. Our price is based on our shop drawings. Additions or deletions of detail changes may result in additional charges or production delays.
- Seal Crafts responsibility shall be limited to providing window products in accordance with approved shop drawings. Customer is responsible for verifying all information included in shop drawings is correct and accurate. Signing and returning these shop drawings to Seal Craft means that you have thoroughly reviewed them and accept responsibility for their accuracy.
- Seal Craft does not warrant build sizes for fit or against variations in opening sizes. Accuracy of all dimensions and installation engineering details are the sole responsibility of the purchaser and installing subcontractor.
- Seal Craft must be notified of field testing requirements before the order is placed. Field testing are to be pursuant to AAMA 502.08. Test pressure shall be based on the design pressure of the building and shall be calculated in accordance with AAMA 502.08. Testing shall be performed as quickly as possible after first window is installed.

WARRANTY:

- Seal Crafts warranty document is available at www.seal-craft.com.
- Seal Crafts warranty shall be null and void in cases where installation instructions are not followed, where products are installed into sub standard construction substrates or if there have been unauthorized modifications to the product or installation procedure.

SPECIAL INSTRUCTIONS TO INSTALLER:

- All window systems shall be installed pursuant to AAMA Publication IPCB-08, ASTM E 2112, and AAMA 2400-02. These documents can be located at www.seal-craft.com together with Seal Craft product specific installation and maintenance instructions.
- Installer must properly shim and adjust all windows for proper operation. Shim jambs of all windows at all fastener locations and especially at meeting rail of single and double hung windows.
- Customer to verify that all opening dimensions and existing wall conditions are acceptable to receive window installation if not, please notify general contractor or architect as appropriate.
- Installer is responsible for properly sealing around windows or anywhere there is an exterior joint that is not factory sealed or weather stripped.
- Installer is responsible to ensure that all window to subframe, panning, and mullion weather strip joints are fully compressed and sealed during field assembly.
- Seal fasteners at every location where fastener pierces subsill of window system.
- Seal Craft does not provide fasteners, blocking, flashing, or insulation.
- Seal Craft will not be responsible for condensation at window sills due to sill pans supplied and installed by others.
- Type and placement of anchors as determined by others.

NOTICES:

- Ensure that the window installation subcontractor has been provided with a set of approved shop drawings for the project PRIOR to the commencement of installation activities.
- Should questions arise call 1-800-844-4486 before proceeding with installation.
- These shop drawings constitute the Copy Written intellectual property of Seal Craft and may not be divulged to parties other than the architect and installing subcontractor without explicit written approval by Seal Craft.

DELIVERY, UNLOADING, AND STORAGE:

- Before windows are delivered pre-plan for a suitable storage area to keep the window products secure, clean, dry, and protected from temperature extremes.
- Seal Craft will provide concise packing slips for all materials delivered. Ensure that materials are checked in and verified against the packing list.
- Any material shortages or damage must be noted on the drivers bill of lading or shipping ticket. In no case will Seal Craft acknowledge any freight claims made after 30 days past the delivery date.

PROJECT SPECIFIC SELECTIONS:

G1 GLAZING REQUIREMENTS
1/4" LOW E OVER 1/4" CLEAR
272 #2

FINISH
2603 BLACK 768

SHOP DRAWING/SUBMITTAL REVIEW

- REVIEWED AND APPROVED APPROVED WITH CHANGES NOTED
 REVISE AND RESUBMIT REJECTED _____

REVIEW IS FOR THE GENERAL CONFORMANCE WITH THE DESIGN CONCEPT AND THE INFORMATION, SPECIFIC TO EXACT DIMENSIONS, DETAILS, AND QUANTITIES GIVEN IN THE SUBMITTED SHOPS.

BY: _____
DATE: _____

HOTEL PROJECTS:

- On all Horizontal Slider jobs (4100 Series) Sash stops to be installed in head only. Use provided screws. Installation of Sash stop in sill may block weep holes and cause water intrusion.
- Need screen springs in 1 height of screens (Jamb side).

DATE ORIGINATED:	4/2/21	DRAWN BY:	MAG	CHECKED BY:	BVP
KAUL GLOVE BLD			DETROIT, MI		
SEAL CRAFT Architectural Window Systems <small>1207 Airport Dr. Shreveport, Louisiana 71107 Office: 1.800.844.4486 Fax: 318.221.7685</small>					
REVISIONS	REV.	DATE	DESCRIPTION		
JOB NUMBER:			REV.		
SHEET 01 OF 04					

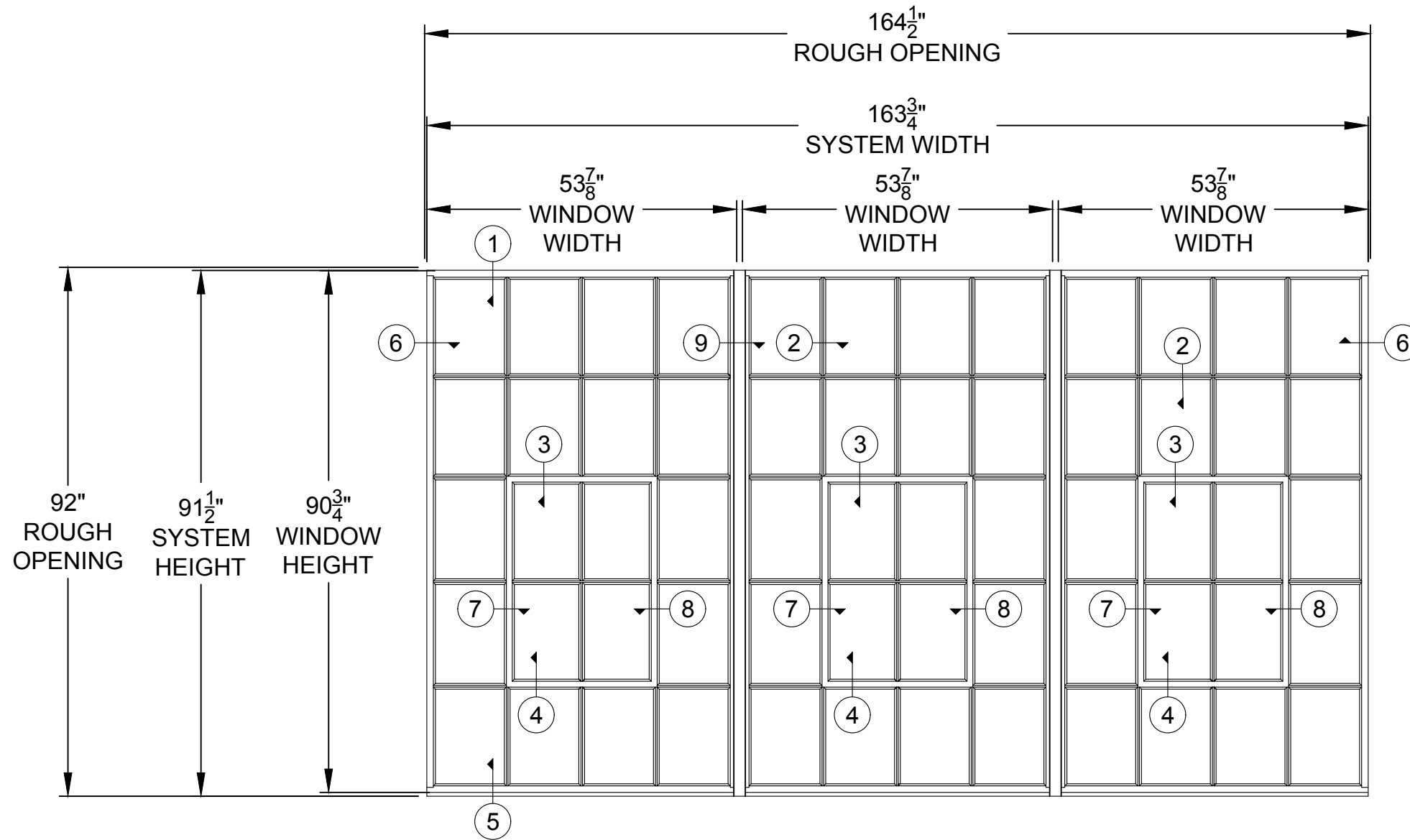

MARK	OPT 1
TYPE	1200H
QTY	1

REVISIONS

REV.	DATE	DESCRIPTION

JOB NUMBER: REV.

DATE ORIGINATED:	4/2/21
DRAWN BY:	MAG
CHECKED BY:	BVP
KAUL GLOVE BLD	
DETROIT, MI	

SEAL CRAFT
Architectural Window Systems
 1207 Airport Dr. Shreveport, Louisiana 71107
 Office: 1.800.844.4486
 Fax: 318.221.7685

EXTERIOR

1 5/8"

1"

1 3/4"

1"

1 3/4"

2 1/8"

1 1/2"

5/8"

NEW WINDOW

① HEAD

② MUNTIN

③ MUNTIN

INTERIOR

② MUNTIN

④ MUNTIN

⑤ SILL

EXTERIOR

2"

1"

1 3/4"

1"

1 3/4"

2 1/4"

2"

EXISTING WINDOW

① HEAD

② MUNTIN

③ IMPOST

② MUNTIN

④ IMPOST

⑤ SILL

INTERIOR

DATE ORIGINATED:	4/2/21
DRAWN BY:	MAG
CHECKED BY:	BVP

KAUL GLOVE BLD

DETROIT, MI

SEAL CRAFT
 Architectural Window Systems
 1207 Airport Dr. Shreveport, Louisiana 71107
 Office: 1.800.844.4486
 Fax: 318.221.7685

REVISIONS

REV.	DATE	DESCRIPTION

JOB NUMBER: REV.

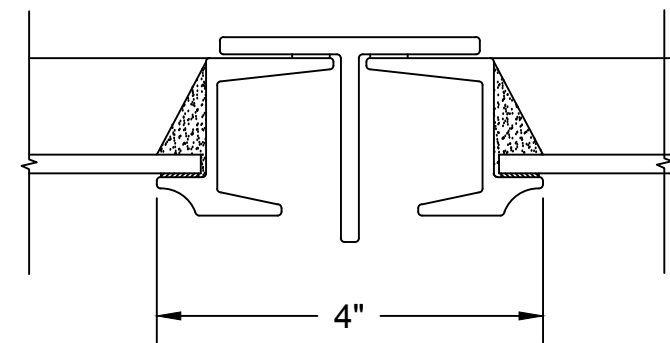
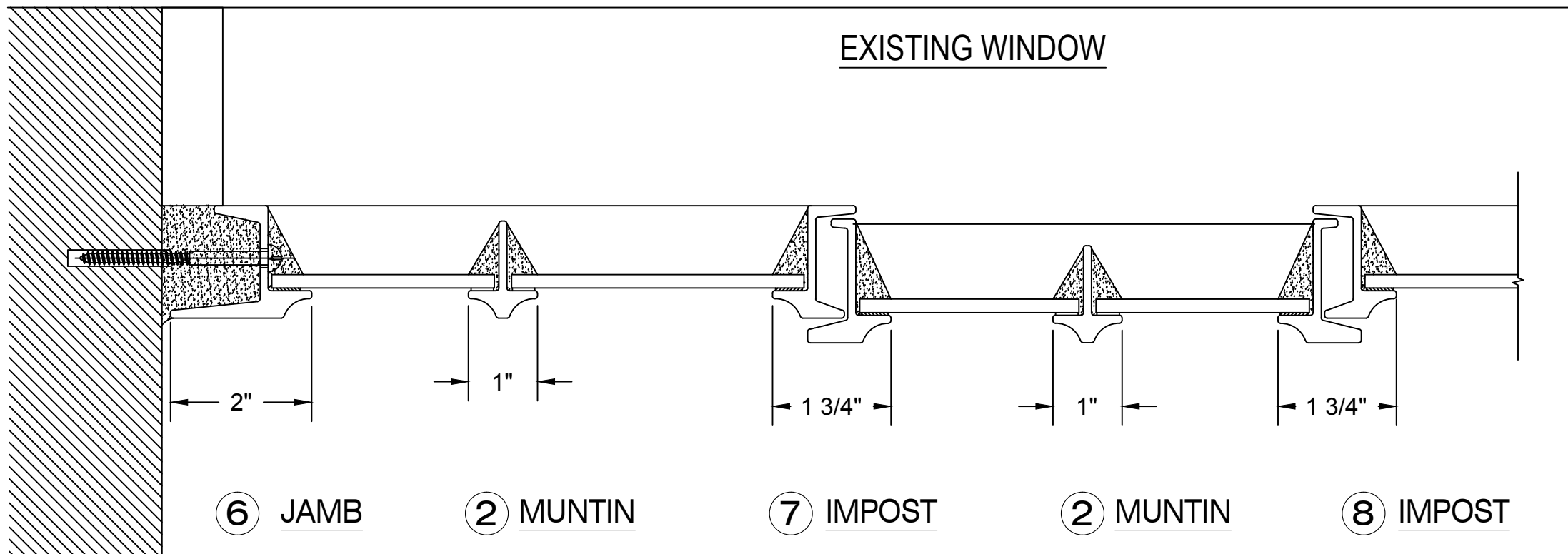
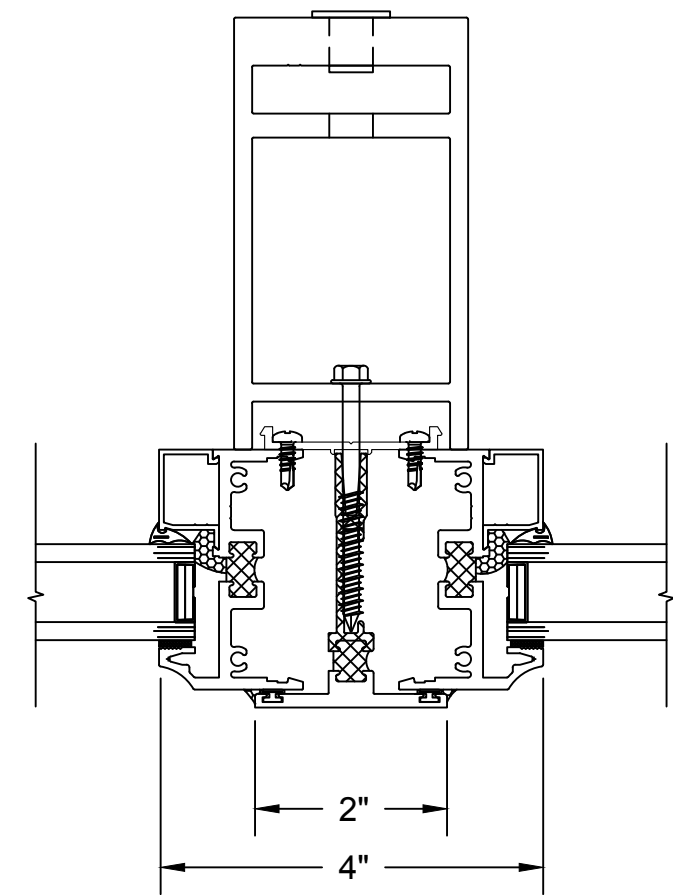
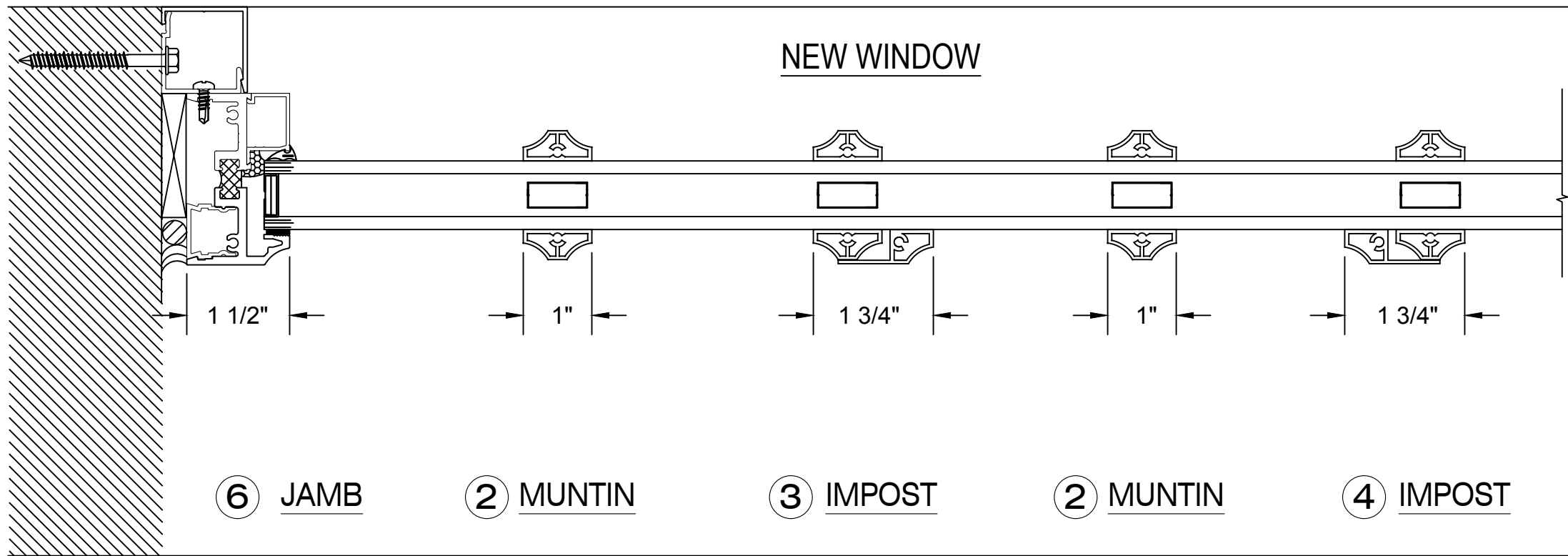

DATE ORIGINATED: 4/2/21
 DRAWN BY: MAG
 CHECKED BY: BVP

KAUL GLOVE BLD
 DETROIT, MI

SEAL CRAFT
Architectural Window Systems
 1207 Airport Dr. Shreveport, Louisiana 71107
 Office: 1.800.844.4486
 Fax: 318.221.7685

REVISIONS	
REV.	DESCRIPTION

JOB NUMBER: REV.