

From: [Kristyn Patterson](#)
To: [Dan Rieden](#)
Cc: [Historic District Commission \(Staff\)](#); [Kelechi Okoroha](#)
Subject: [EXTERNAL]Re: [EXTERNAL]Re: HDC Meeting update: 2522 W. Boston Blvd
Date: Monday, November 29, 2021 11:18:27 AM

Hello Dan,

I am a tad bit confused. Please see my comments below? Please provide clarity and I will get all the responses over to you before the end of the day.

I hope you had a wonderful Thanksgiving.

Warm regards,

Kris
773.551.0027

On Nov 24, 2021, at 3:55 PM, Dan Rieden <riedenda@detroitmi.gov> wrote:

Good afternoon Ms. Patterson,

Staff has reviewed the material to date today and there are still materials missing from this application that help us to understand the case. We do need this information so that we can bring your case before the Historic District Commission (HDC), so please respond with the following items by end of day Monday, so that we can continue with this application.

1. Please provide a product data sheet, also know as a cut sheet, of the 41 installed windows. This should include the product's dimensions and materiality. (We know this is clad-wood, but is it aluminum clad wood, vinyl clad wood, or fiberglass clad wood?)

The measurements I've provided for each replacement window is the size of the current windows. The current windows are vinyl. Does this suffice as a response?

- 1.
2. Please provide a count of windows installed per

41 windows

- 2.
3. In your response to bullet #4, you describe that original windows were discovered behind drywall on the inside and covered from the outside. Please provide a photo of the interior and exterior of the wood-paneled windows that were in the front and side of the house. Please make sure these are JPG photos with high resolution, not the previously submitted PDF versions. Also, please provide photos that were taken before the work was done (interior and exterior), these appear to be available from your H&R contractor.

I made a mistake. I meant in regards to where the shutters were. Where the shutters were on the first floor there was a gap between the drywall and brick where a window was. This is in regards to the first floor only. The shutters were covering missing windows but the home itself had windows where the shutters were.

- 3.
4. The shutters that were removed without approval would be considered another element that is in violation. Are you including the shutters in this application to address this violation? If so, we would need a description of what will be done to return the shutters, any repair of them,

and any painting (color, type) of them.

I had no intention of replacing the shutters as they were not apart of the original home. We discovered this when removing the drywall and noting the shutters were covering original windows. The windows weren't present but the spacing was.

4.

Thank you!

Sincerely,

Daniel Rieden PLA/ASLA

Lead Landscape Architect | Historic Preservation Team
Planning & Development Department | City of Detroit
Coleman A. Young Municipal Center, 2 Woodward Avenue, Suite 808, Detroit, MI 48226
Phone: 313.224.1357
Email: riedenda@detroitmi.gov
Website: Detroitmi.gov/pdd

Michael E. Duggan, Mayor

In order to ensure your safety and ours during the COV-ID 19 pandemic, the Historic Preservation Team will be working remotely.

From: Kristyn Patterson <kpgproperties@gmail.com>
Sent: Tuesday, November 23, 2021 10:25 PM
To: Dan Rieden <riedenda@detroitmi.gov>
Cc: Historic District Commission (Staff) <hdc@detroitmi.gov>; Kelechi Okorooha <krokoroha@gmail.com>
Subject: [EXTERNAL]Re: HDC Meeting update: 2522 W. Boston Blvd

Hello Dan,

My apologies for the delay. Please see my comments below. Please call/email if you need anything else from me.

Warm regards,

Kris
773.551.0027

On Nov 19, 2021, at 2:38 PM, Dan Rieden <riedenda@detroitmi.gov> wrote:

Dear Ms. Patterson,

I would like to introduce myself so you have my information available. Please note that staff is working from home, so please reach me by this email. Upon an initial review of your application material I do have a few questions listed here. It would be most helpful if you're able to respond by end of day Tuesday, November 23rd.

- I understand that you reported that 70% of the windows were reported missing upon purchase of the home. Do you have any photos that show this condition?

Unfortunately, I do not have any pictures.

•

From: [Kristyn Patterson](mailto:Kristyn.Patterson@gmail.com)
To: [Dan Rieden](mailto:Dan.Rieden@detritmi.gov)
Cc: [Kristyn Patterson](mailto:Kristyn.Patterson@gmail.com)
Subject: [EXTERNAL]Re: [EXTERNAL]Re: [EXTERNAL]Re: HDC Meeting update: 2522 W. Boston Blvd
Date: Monday, November 29, 2021 1:15:45 PM
Attachments: [DanRieden - 1.tif](#)
[Covered windows.tif](#)

Hello Dan,

I hope the attachment suffices for #1

#2 There's a total of 42 windows. There's 10 windows in the front of the home, 16 windows on the right side of the house, 5 windows on the back of the home, 11 windows on the left side of the home. No windows were kept.

#3 There's currently no pictures available Outside of the ones below. Please let me know if they attached as a JPEG. The only pictures taken of the home are the images in the PDF sent with the application.

#4 I no longer have the shutters. They cannot be replaced on the first floor as there were windows hiding behind them. I will replace the shutters at the top of the front of the home. All 4 shutters will be the yellow color and exact shape and size of the ones previously on the home.

ATTENTION: This email was sent from an external source. Please be extra cautious when opening attachments or clicking links.



Please shoot me a call to explain what else is needed as I am confused in the information above does not suffice.

Kris
773.551.0027

On Nov 29, 2021, at 11:06 AM, Dan Rieden <riedenda@detroitmi.gov> wrote:

Ms. Patterson,

We do need a full response to these questions. Some of the questions are missing parts from their original, so I am listing them again here. (For example, #2)

- #1. Please provide a product data sheet, also known as a cut sheet, of the 41 installed windows. This should include the product's dimensions and materiality. (We know this is clad-wood, but is it aluminum clad wood, vinyl clad wood, or fiberglass clad wood?) WE STILL HAVE NOT RECEIVED THIS INFORMATION.
- Please provide a count of windows installed per side of the house. Please provide a count of windows kept per side of the house. WE STILL HAVE NOT RECEIVED THIS INFORMATION.
- In your response to bullet #4, you describe that original windows were discovered behind drywall on the inside and covered from the outside. Please provide a photo of the interior and exterior of the wood-paneled windows that were in the front and side of the house. Please make sure these are JPG photos with high resolution, not the previously submitted PDF versions. Also, please provide photos that were taken before the work was done (interior and exterior); these appear to be available from your H&R contractor. WE STILL NEED PHOTOS OF THE BEFORE AND AFTER CONDITIONS OF THESE WINDOWS, WE HAVE NOT RECEIVED THIS INFORMATION.
- The shutters that were removed without approval would be considered another element that is in violation. Are you including the shutters in this application to address this violation? If so, we would need a description of what will be done to return the shutters, any repair of them, and any painting (color, type) of them.

I had no intention of replacing the shutters as they were not apart of the original home. We discovered this when removing the drywall and noting the shutters were covering original windows. The windows weren't present but the spacing was.

The shutters are in reference to the front elevation windows where there were shutters on the second and first floor windows and on the sides. Please address these shutters.

WE STILL HAVE NOT RECEIVED AN ANSWER TO THIS QUESTION.

Kristyn, please note that this application is not complete and will have to be pulled from the agenda if we don't receive this information.

Thank you.

Daniel Rieden FLA0616A
Lead Landscape Architect | Historic Preservation Team
Planning & Development Department | City of Detroit
Cassman A. Young Municipal Center, 2 Woodward Avenue, Suite 808, Detroit, MI 48226
Phone: 313.224.1387
Email: driedenda@detroitmi.gov
Website: www.detroitmi.gov
Michael E. Duggan, Mayor

In order to ensure your safety and ours during the COVID 19 pandemic, the Historic Preservation Team will be working remotely.

From: Kristyn Patterson <kpatterson19@gmail.com>
Sent: Monday, November 29, 2021 11:18 AM
To: Dan Rieden <riedenda@detroitmi.gov>
Cc: Historic District Commission (Staff) <hdc@detroitmi.gov>; Kelechi Okoroah <kokoroah@gmail.com>
Subject: [EXTERNAL]Re: [EXTERNAL]Re: HDC Meeting update: 2522 W. Boston Blvd

Hello Dan,

I am a tad bit confused. Please see my comments below? Please provide clarity and I will get all the responses over to you before the end of the day.

I hope you had a wonderful Thanksgiving.

Warm regards,

Kris
773.551.0027

From: [Kristyn Patterson](#)
To: [Dan Rieden](#)
Cc: [Kelechi Okoroha](#)
Subject: [EXTERNAL]Re: [EXTERNAL]Re: [EXTERNAL]Re: HDC Meeting update: 2522 W. Boston Blvd
Date: Monday, November 29, 2021 1:13:10 PM
Attachments: [PastedGraphic-3.tiff](#)

Please see the image below. When the home was purchased, there was shutters covering these two windows from the exterior. From the interior there was drywall covering what should have been windows but was just openings in the brick for windows. Which was the original part of the home, not the shutters on the first floor.



On Nov 29, 2021, at 12:07 PM, Kristyn Patterson <kpgproperties@gmail.com> wrote:

Hello Dan,

I hope the attachment suffices for #1

#2 There's a total of 42 windows. There's 10 windows in the front of the home. 16 windows on the right side of the house. 5 windows on the back of the home. 11 windows on the left side of the home. No windows were kept.

#3 There's currently no pictures available Outside of the ones below. Please let me know if they attached as a JPEG. The only pictures taken of the home are the images in the PDF sent with the application.

#4 I no longer have the shutters. They cannot be replaced on the first floor as there were windows hiding behind them. I will replace the shutters at the top of the front of the home. All 4 shutters will be the yellow color and exact shape and size of the ones previously on the home.

<297F3EA3-16A1-4972-8EA7-22086E9C463C.jpeg>

<PastedGraphic-1.tiff>

Please shoot me a call to explain what else is needed as I am confused in the information above does not suffice.

Kris
773.551.0027
<current windows.pdf>

On Nov 29, 2021, at 11:06 AM, Dan Rieden <riedenda@detroitmi.gov> wrote:

Ms. Patterson,

We do need a full response to these questions. Some of the questions are missing parts from their original, so I am listing them again here. (For example, #2)

1. #1. Please provide a product data sheet, also know as a cut sheet, of the 41 installed windows. This should include the product's dimensions and materiality. (We know this is clad-wood, but is it aluminum clad wood, vinyl clad wood, or fiberglass clad wood?) WE STILL HAVE NOT RECEIVED THIS INFORMATION.
2. Please provide a count of windows installed per side of the house. Please provide a count of windows kept per side of house. WE STILL HAVE NOT RECEIVED THIS INFORMATION.
3. In your response to bullet #4, you describe that original windows were discovered behind drywall on the inside and covered from the outside. Please provide a photo of the interior and exterior of the wood-paneled windows that were in the front and side of the house. Please make sure these are JPG photos with high resolution, not the previously submitted PDF versions. Also, please provide photos that were taken before the work was done (interior and

From: [Kristyn Patterson](#)
To: [Dan Rieden](#)
Cc: [Historic District Commission \(Staff\)](#); [Kelechi Okorooha](#)
Subject: [EXTERNAL]Re: HDC Meeting update: 2522 W. Boston Blvd
Date: Tuesday, November 23, 2021 10:24:53 PM

Hello Dan,

My apologies for the delay. Please see my comments below. Please call/email if you need anything else from me.

Warm regards,

Kris
773.551.0027

On Nov 19, 2021, at 2:38 PM, Dan Rieden <riedenda@detroitmi.gov> wrote:

Dear Ms. Patterson,

I would like to introduce myself so you have my information available. Please note that staff is working from home, so please reach me by this email. Upon an initial review of your application material I do have a few questions listed here. It would be most helpful if you're able to respond by end of day Tuesday, November 23rd.

- I understand that you reported that 70% of the windows were reported missing upon purchase of the home. Do you have any photos that show this condition?

Unfortunately, I do not have any pictures.

-
- Do you have any photos of the original windows, inside and outside, before they were removed?

Unfortunately, I do not have any pictures of the home nor original windows before they were removed.

-
- The H&R window repair document, reports conditions of some windows. Are there any supporting documents or photos that show their condition and which ones are being referenced? Is there any documentation that shows the original windows' dimensions: the header, jam, sill, muntins, etc.?

H&R Window Repair took a look at the windows that weren't fully fire damaged and still present at the home. I do not have pictures of the windows they reviewed. The current windows fit into the current headers and are the same dimensions of the previous windows. I do not have any other dimensions outside of the ones provided.

-
- The front elevation showed wood paneling on top and on either side of the first floor windows were replaced with windows. Can you describe the decision to change this original design?

The true original windows of the home when it was built had original windows were the wood

paneling was. Once the drywall was removed, it was discovered that the original windows were present and later drywalled on the inside and covered from the outside. I wanted to bring the original appearance of the home back to life.

-
- It appears that the original window on the other side of the front floor elevation was kept. Please confirm.

The original window was now kept. It was replaced. The window was one of the windows H&R reviewed and stated need to be replaced.

-
- On page 9 of your application, there's window opening that is much larger than the window replaced. (this is above the driveway.) Please describe what happened here. Do you have any recent photos?

The window company ordered the incorrect size window. We are awaiting the new window to arrive.

-
- Have you kept any of the original window material, or are they all disposed?

All of the wood surrounding the windows is intact and in good condition.

-
- It appears that all windows are clad-wood, and all windows that have grilles are located between the glass. Please confirm.

Confirming

-
- Please provide total number of windows replaced or retained per side of house.

There's 41 windows in total.

Please let me know if you have any other questions.

-

Let me know if you have any questions.

Sincerely,

Daniel Rieden PLA/ASLA

Lead Landscape Architect | Historic Preservation Team
Planning & Development Department | City of Detroit
Coleman A. Young Municipal Center, 2 Woodward Avenue, Suite 808, Detroit, MI 48226
Phone: 313.224.1357
Email: riedenda@detroitmi.gov
Website: Detroitmi.gov/pdd

Michael E. Duggan, Mayor

In order to ensure your safety and ours during the COV-ID 19 pandemic, the Historic Preservation Team will be working remotely.

From: Brendan Cagney <cagneyb@detroitmi.gov>

From: [Kristyn Patterson](#)
To: [Dan Rieden](#)
Cc: [Kelechi Okorooha](#)
Subject: [EXTERNAL]Re: [EXTERNAL]Re: [EXTERNAL]Re: HDC Meeting update: 2522 W. Boston Blvd
Date: Monday, November 29, 2021 4:11:20 PM

Thank you for explaining. I will be replacing the shutters with wood.

I am on the phone with the supplier now trying to get the cut sheet. I should have that before end of day. Thank you for your patience.

Warm regards,

Kristyn Patterson

On Nov 29, 2021, at 1:35 PM, Dan Rieden <riedenda@detroitmi.gov> wrote:

Hi Kristyn,

#1., The product sheet (cut sheet) is not yet received. The material you sent was previously sent to us. However, this does not answer the full materiality of the window product... for example, is this vinyl -clad wood or aluminum clad wood? The product sheet will also show us a section cut that shows the products dimension and how these products are coming together. Please ask your supplier to provide this information.
#4., Will the new shutters be wood material?

Thanks,

Daniel Rieden PLAIA/SLA
Lead Landscape Architect | Historic Preservation Team
Planning & Development Department | City of Detroit
Coleman A. Young Municipal Center, 2 Woodward Avenue, Suite 808, Detroit, MI 48226
Phone: 313.224.1357
Email: riedenda@detroitmi.gov
Website: detroitmi.gov/pld
Michael E. Duggan, Mayor
In order to ensure your safety and ours during the COVID 19 pandemic, the Historic Preservation Team will be working remotely.

From: Kristyn Patterson <kgpproperties@gmail.com>
Sent: Monday, November 29, 2021 1:07 PM
To: Dan Rieden <riedenda@detroitmi.gov>
Cc: Kelechi Okorooha <krokoroha@gmail.com>
Subject: [EXTERNAL]Re: [EXTERNAL]Re: [EXTERNAL]Re: HDC Meeting update: 2522 W. Boston Blvd

Hello Dan,

I hope the attachment suffices for #1

#2 There's a total of 42 windows. There's 10 windows in the front of the home. 16 windows on the right side of the house. 5 windows on the back of the home. 11 windows on the left side of the home. No windows were kept.

#3 There's currently no pictures available Outside of the ones below. Please let me know if they attached as a JPEG. The only pictures taken of the home are the images in the PDF sent with the application.

#4 I no longer have the shutters. They cannot be replaced on the first floor as there were windows hiding behind them. I will replace the shutters at the top of the front of the home. All 4 shutters will be the yellow color and exact shape and size of the ones previously on the home.

ATTENTION: This email was sent from an external source. Please be extra cautious when opening attachments or clicking links.

From: [Kristyn Patterson](#)
To: [Dan Rieden](#)
Cc: [Kelechi Okoroha](#)
Subject: [EXTERNAL]Re: [EXTERNAL]Re: [EXTERNAL]Re: [EXTERNAL]Re: HDC Meeting update: 2522 W. Boston Blvd
Date: Monday, November 29, 2021 4:23:09 PM
Attachments: [Report for windows.pdf](#)

Hi Dan,

I received the attached document from the supplier. Does this suffice?

Kris

ATTENTION: This email was sent from an external source. Please be extra cautious when opening attachments or clicking links.

On Nov 29, 2021, at 1:35 PM, Dan Rieden <riedenda@detroitmi.gov> wrote:

Hi Kristyn,

#1., The product sheet (cut sheet) is not yet received. The material you sent was previously sent to us. However, this does not answer the full materiality of the window product... for example, is this vinyl -clad wood or aluminum clad wood? The product sheet will also show us a section cut that shows the products dimension and how these products are coming together. Please ask your supplier to provide this information.

#4., Will the new shutters be wood material?

Thanks,

Daniel Rieden PLA/ASLA

Lead Landscape Architect | Historic Preservation Team
Planning & Development Department | City of Detroit
Coleman A. Young Municipal Center, 2 Woodward Avenue, Suite 808, Detroit, MI 48226
Phone: 313.224.1357
Email: riedenda@detroitmi.gov
Website: Detroitmi.gov/pdd

Michael E. Duggan, Mayor

In order to ensure your safety and ours during the COV-ID 19 pandemic, the Historic Preservation Team will be working remotely.

From: Kristyn Patterson <kpgproperties@gmail.com>

Sent: Monday, November 29, 2021 1:07 PM

To: Dan Rieden <riedenda@detroitmi.gov>

Cc: Kelechi Okoroha <krokoroha@gmail.com>

Subject: [EXTERNAL]Re: [EXTERNAL]Re: [EXTERNAL]Re: HDC Meeting update: 2522 W. Boston Blvd

Hello Dan,

I hope the attachment suffices for #1

#2 There's a total of 42 windows. There's 10 windows in the front of the home. 16 windows on the right side of the house. 5 windows on the back of the home. 11 windows on the left side of the home. No windows were kept.

#3 There's currently no pictures available Outside of the ones below. Please let me know if they attached as a JPEG. The only pictures taken of the home are the images in the PDF sent with the application.

#4 I no longer have the shutters. They cannot be replaced on the first floor as there were windows hiding behind them. I will replace the shutters at the top of the front of the home. All 4 shutters will be the yellow color and exact shape and size of the ones previously on the home.

ATTENTION: This email was sent from an external source. Please be extra cautious when opening attachments or clicking links.

<image001.jpg>

From: [Kristyn Patterson](#)
To: [Dan Rieden](#)
Subject: [EXTERNAL]Re: [EXTERNAL]Re: [EXTERNAL]Re: [EXTERNAL]Re: [EXTERNAL]Re: [EXTERNAL]Re: HDC Meeting update: 2522 W. Boston Blvd
Date: Tuesday, November 30, 2021 12:57:06 AM

Hello Dan,

I spoke to the manufacturer and they stated the document provided is the most detailed document they have. I don't know how to go about providing you with the document you're requesting. Please advise.

Warm regards,

Kristyn Patterson

On Nov 29, 2021, at 4:43 PM, Dan Rieden <riedenda@detroitmi.gov> wrote:

Kristyn,

The documents provided by the manufacture should state that they are vinyl. If I'm missing this, please show me where, but I don't see it. Please ask them to provide this.

Thanks,

Daniel Rieden PLA/ASLA

Lead Landscape Architect | Historic Preservation Team
Planning & Development Department | City of Detroit
Coleman A. Young Municipal Center, 2 Woodward Avenue, Suite 808, Detroit, MI 48226
Phone: 313.224.1357
Email: riedenda@detroitmi.gov
Website: Detroitmi.gov/pdd
Michael E. Duggan, Mayor

In order to ensure your safety and ours during the COV-ID 19 pandemic, the Historic Preservation Team will be working remotely.

From: Kristyn Patterson <kpgproperties@gmail.com>
Sent: Monday, November 29, 2021 5:33 PM
To: Dan Rieden <riedenda@detroitmi.gov>
Subject: [EXTERNAL]Re: [EXTERNAL]Re: [EXTERNAL]Re: [EXTERNAL]Re: [EXTERNAL]Re: HDC Meeting update: 2522 W. Boston Blvd

Hello Dan,

The manufacturer does not provide a cut sheet. The materials are all vinyl. Can you send me an example of a cut sheet and I can complete one quickly? I'm sorry for all of my confusion.

Warm regards,

Kristyn Patterson

On Nov 29, 2021, at 4:27 PM, Dan Rieden <riedenda@detroitmi.gov> wrote:

Kristyn,

This is very similar to the previous information. We do need to know the material composition of the windows and this is not listed in the report you sent. A cutsheet that shows the section cut with labels would provide this.

Daniel Rieden PLA/ASLA

Lead Landscape Architect | Historic Preservation Team
Planning & Development Department | City of Detroit
Coleman A. Young Municipal Center, 2 Woodward Avenue, Suite 808, Detroit, MI 48226
Phone: 313.224.1357
Email: riedenda@detroitmi.gov
Website: Detroitmi.gov/pdd
Michael E. Duggan, Mayor

In order to ensure your safety and ours during the COV-ID 19 pandemic, the Historic Preservation Team will be working remotely.

From: Kristyn Patterson <kpgproperties@gmail.com>
Sent: Monday, November 29, 2021 4:20 PM
To: Dan Rieden <riedenda@detroitmi.gov>
Cc: Kelechi Okorooha <krokoroha@gmail.com>
Subject: [EXTERNAL]Re: [EXTERNAL]Re: [EXTERNAL]Re: [EXTERNAL]Re: HDC Meeting update: 2522 W. Boston Blvd

Hi Dan,

I received the attached document from the supplier. Does this suffice?

Proposal



- 23641 John R.
- Hazel Park, Michigan 48030
- Phone: (248) 544-8282
- Fax: (248) 544-8122
- www.hrwindowrepair.com



PROPOSAL SUBMITTED TO KRISTYN PATTERSON	PHONE	DATE 09/27/21
ADDRESS 2322 W. BOSTON BLVD.	JOB NAME AND LOCATION	
DETROIT, MI	TOTAL SEE BELOW	DEPOSIT
		BALANCE

We propose here to provide material and labor—complete in accordance with below specifications, for the sum of _____ d ollars.
N/A

Approximate completion time within _____ from receipt of deposit.

TERMS: 1/2 of purchase price upon acceptance of proposal and balance due C.O.D. at completion of work.

All material is guaranteed to be as specified. All work is to be completed in a workmanlike manner according to standard practices. Any alteration or deviation from specifications involving extra costs will be executed only upon written orders, and will become an extra charge over and above the estimate. All agreements contingent upon strikes, accidents or delays beyond our control. Owner to carry fire, tornado and other necessary insurance. Our workers are fully covered by Workmen's Compensation insurance.

H & R WINDOW REPAIR COMPANY

Authorized
Signature

Thomas Rushton

NOTE: This proposal may be withdrawn by us if not accepted within thirty (30) days.

We hereby submit specifications and estimates, subject to all terms and conditions as follows:

LETTER OF EXPLANATION AS FOLLOWS:

DUE TO THE EXTENT OF DAMAGE / MISSING FRAMING / DETERIORATION OF WALL STRUCTURE TO BE REBUILT IT IS NOT FEASIBLE TO LOOK AT REPAIRING OR RESTORATION OF EXISTING PARTS AND PIECES OF OLD WINDOWS

WOULD RECOMMEND REPLACING EXISTING WINDOWS (WHAT IS LEFT OF THEM) WITH AN ACCEPTABLE WINDOW MANUFACTURER THAT SIMULATES THE OLD STYLE WOOD DOUBLE HUNG WINDOWS OF THE ERA.

LOOK INTO ACCEPTABLE WINDOW MANUFACTURERS THROUGH THE HDC - BEST MATCH WOULD BE "LINCOLN" BRAND WINDOWS (IF THEY ARE LISTED)

SEE EXCLUSION ON BACK

Removal and reinstallation of all window treatments are the responsibility of the homeowner.

Acceptance of Proposal — The above prices, specifications and conditions are satisfactory and are hereby accepted. You are authorized to do the work as specified. Payment will be made as outlined above.

Signature _____

Date of Acceptance _____

Signature _____

If you accept our proposal, please sign on bottom and return top copy with deposit. Thank you.

32501 VAN DYKE AVE
WARREN, MI 48093-8135

(586) 795-0028
(586) 819-2126



Design & Buy™ WINDOWS

Design #: 331959962836

Estimated Price: \$30,608.30

How to purchase at the store:

1. Take this packet to any Menards store.
2. Have a Menards Team Member enter the Design ID into the Window Designer Program.
3. Have a Menards Team Member print purchasing documents.
4. Take the Special Order Contract to the register and pay.

How to recall and purchase a saved design at home:

1. Go to Menards.com
2. Login to your account.
3. Go to the Window Designer from the Project Center and select Search Saved Designs.
4. Enter the Design ID or select from your open projects to load into the Window Designer.
5. Add your design to the cart and purchase.

Line Item	Quantity	Product Description	Unit Price	Total Price
100-1	8	Clad W-2500, Direct Set, 21.25 x 12	\$385.27	\$3,082.16

Actual Size: 21.25 x 12

Room: 1st Floor front room
Unit is viewed from the outside looking in.



ProductTileBackendName = JELD-WEN W-2500 Clad Picture
Assembly = Full Unit,
Exterior Trim Type = Nailing Flange removed (Block frame), Exterior Trim Options = No,
Country Where Unit Will Be Installed = USA
(Certified) Measurement Type = Actual Size,
Frame Width = Custom
Size, Custom Frame
Width = 21.25, Frame
Height = Custom Size,
Custom Frame Height = 12
Interior Material Type = Auralast
Pine, Interior Finish Type = Painted,
Interior Finish = Paint
Desert Sand, Exterior Finish = Desert Sand Extension
Jamb = 4 9/16",
Thickness of extension jamb material = (Standard) 9/16 " Thick Jamb Extension
Performance Grade Rating = PG 35
Glass Energy Efficiency = Energy
Star, Installation Zip Code = 48203,
Energy Star Zone = Energy Star - Northern,
Energy Star Low-E Options = Low-E EC 366 (i89 In/366 Out), Glass Type = Standard,
Neat Glass = No,
Glass Thickness = Standard Default Thickness,
Protective Film = No Protective Film,
Glass Spacer Color = Black
Spacer, Air Space Options = Argon
Grille Type = No
Grilles U-Factor = 0.22,
Solar Heat Gain Coefficient = 0.23, Visible Light Transmittance = 0.55,
Condensation Resistance = 45, CPD# = JEL-N-889-03292-00001
Is this a Reorder? = No
Manufacturer = JELD-WEN, Rantoul(IL), Catalog Version Date = 07/29/2021, Catalog Version = 21.2.23.5

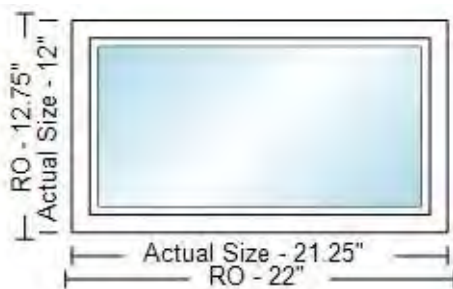

Line Item	Quantity	Product Description	Unit Price	Total Price
-----------	----------	---------------------	------------	-------------

200-1	8	Clad W-2500, Double Hung,	\$812.75	\$6,502.00
-------	---	------------------------------	----------	------------

Rough Opening: 22.125 x 48.75

21.375 x 48

Actual Size: 21.375 x 48

Room: 1st floor front DH
Unit is viewed from the outside looking in.

ProductTileBackendName = JELD-WEN W-2500 Clad Double Hung
 Assembly = Full Unit,
 Sash Model = Standard,
 Exterior Trim Type = Nailing Flange removed (Block frame),
 Exterior Trim Options = No,
 Country Where Unit Will Be Installed = USA (Certified)
 Sash Split = Even Divide,
 Measurement Type = Actual Size,
 Frame Width = 21 3/8",
 Frame Height = 48"
 Interior Material Type = Auralast Pine,
 Interior Finish Type = Painted,
 Interior Finish = Paint Desert Sand,
 Exterior Finish = Desert Sand,
 Sash to Match Exterior Frame Finish = Yes,
 Exterior Sash Finish = Desert Sand
 Extension Jamb = 4 9/16"
 Performance Grade Rating = PG 35
 Hardware Finish = Desert Sand,
 Number of Locks = 1,
 Screen Options = BetterVue Mesh (Standard),
 Screen Frame Finish = Desert Sand
 Glass Energy Efficiency = Energy Star,
 Installation Zip Code = 48203,
 Energy Star Zone = Energy Star - Northern,
 Energy Star Low-E Options = Low-E EC 366 (i89 In/366 Out),
 Glass Type = Standard,
 Neat Glass = No,
 Glass Thickness = Standard Default Thickness,
 Protective Film = No Protective Film,
 Glass Spacer Color = Black Spacer,
 Air Space Options = Argon
 Grille Type = 5/8" Flat GBG,
 Grille Location in Glass = All Lite(s),
 Grille Finish = Desert Sand,
 Grille Pattern = Colonial,
 Number of Squares Wide - Top = 2,
 Number of Squares Wide - Bottom = 2,
 Number of Squares High - Top = 2,
 Number of Squares High - Bottom = 2
 Jamb Liner = Tan Jamb Liner,
 Secondary Vent Stop / Sash Limiter = No Window Opening Control Device
 U-Factor = 0.25,
 Solar Heat Gain Coefficient = 0.19,
 Visible Light Transmittance = 0.45,
 Condensation Resistance = 45,
 CPD# = JEL-N-850-01686-00001
 Is this a Reorder? = No
 Manufacturer = JELD-WEN, Rantoul(IL),
 Catalog Version Date = 07/29/2021,
 Catalog Version = 21.2.23.5
 5/8" Flat Grilles Between Glass (GBG),
 Colonial,
 2W2H

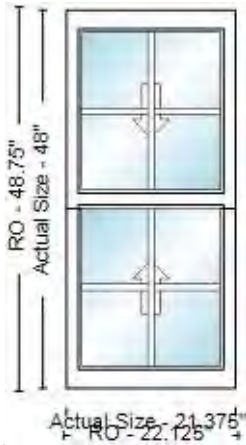

Line Item	Quantity	Product Description	Unit Price	Total Price
-----------	----------	---------------------	------------	-------------

300-1	5	Clad W-5500, Double Slider,	\$1,055.84	\$5,279.20
-------	---	--------------------------------	------------	------------

Rough Opening: 48.0625 x 48.3125

47.3125 x 47.5625

Actual Size: 47.3125 x 47.5625

Room: 1st floor front sliders

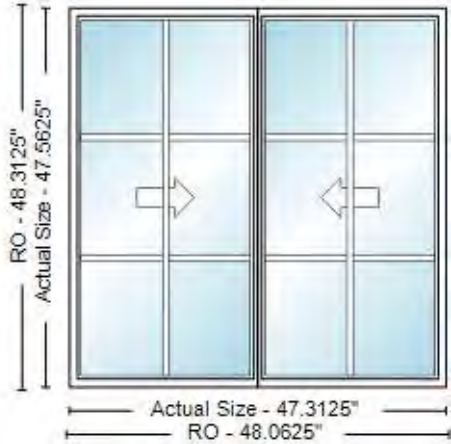

Unit is viewed from the outside looking in.

ProductTileBackendName = JELD-WEN W-5500 Clad Double Slider
 Assembly = Full Unit,
 Exterior Trim Type = Nailing Flange removed (Block frame),Country Where Unit Will Be Installed = USA (Certified), Unit Operation = Left Hand Unit,
 Operation = 2 Panel
 Measurement Type = Actual Size,
 Frame Width = 47 5/16",
 Frame Height = 47 9/16"
 Interior Material Type = Auralast Pine,
 Interior Finish Type = Painted,
 Interior Finish = Paint Desert Sand,
 Exterior Finish = Desert Sand,
 Sash to Match Exterior Frame Finish = Yes,
 Exterior Sash Finish = Desert Sand
 Extension Jamb = 4 9/16"
 Performance Grade Rating = PG 30
 Hardware Finish = Desert Sand,
 Number of Locks = 2,
 Screen Options = BetterVue Mesh (Standard),
 Screen Frame Finish = Desert Sand
 Glass Energy Efficiency = Energy Star,
 Installation Zip Code = 48206,
 Energy Star Zone = Energy Star - Northern,
 Energy Star Low-E Options = Low-E EC 366 (i89 In/366 Out),
 Glass Type = Standard,
 Neat Glass = No,
 Glass Thickness = Standard Default Thickness,
 Protective Film = Protective Film,
 Glass Spacer Color = Black Spacer,
 Air Space Options = Argon,
 Glazing Stop Style = Standard
 Grille Type = 5/8" Flat GBG,
 Grille Location in Glass = All Lite(s),
 Grille Finish = Desert Sand,
 Grille Pattern = Colonial,
 Number of Squares Wide - Left/Right = 2,
 Number of Squares High = 3
 U-Factor = 0.27,
 Solar Heat Gain Coefficient = 0.18,
 Visible Light Transmittance = 0.42,
 Condensation Resistance = 47,
 CPD# = JEL-N-338-00906-00001
 Is this a Reorder? = No
 Manufacturer = JELD-WEN, Rantoul(IL),
 Catalog Version Date = 07/29/2021,
 Catalog Version = 21.2.23.5
 5/8" Flat Grilles Between Glass (GBG),
 Colonial,
 2W3H



Line Item	Quantity	Product Description	Unit Price	Total Price
-----------	----------	---------------------	------------	-------------

600-1	1	Clad W-2500, Double Hung,	\$712.75	\$712.75
-------	---	------------------------------	----------	----------

Rough Opening: 22.125 x 48.75

21.375 x 48

Actual Size: 21.375 x 48

Room: 1st floor backroom DH (no SH in W2500)
Unit is viewed from the outside looking in.



ProductTileBackendName = JELD-WEN W-2500 Clad Double Hung
 Assembly = Full Unit,
 Sash Model = Standard,
 Exterior Trim Type = Nailing Flange removed (Block frame),
 Exterior Trim Options = No,
 Country Where Unit Will Be Installed = USA (Certified)
 Sash Split = Even Divide,
 Measurement Type = Actual Size,
 Frame Width = 21 3/8",
 Frame Height = 48"
 Interior Material Type = Auralast Pine,
 Interior Finish Type = Painted,
 Interior Finish = Paint Desert Sand,
 Exterior Finish = Desert Sand,
 Sash to Match Exterior Frame Finish = Yes,
 Exterior Sash Finish = Desert Sand
 Extension Jamb = 4 9/16"
 Performance Grade Rating = PG 35
 Hardware Finish = Desert Sand,
 Number of Locks = 1,
 Screen Options = BetterVue Mesh (Standard),
 Screen Frame Finish = Desert Sand
 Glass Energy Efficiency = Energy Star,
 Installation Zip Code = 48203,
 Energy Star Zone = Energy Star - Northern,
 Energy Star Low-E Options = Low-E EC 366 (i89 In/366 Out),
 Glass Type = Standard,
 Neat Glass = No,
 Glass Thickness = Standard Default Thickness,
 Protective Film = No Protective Film,
 Glass Spacer Color = Black Spacer,
 Air Space Options = Argon
 Grille Type = 5/8" Flat GBG,
 Grille Location in Glass = All Lite(s),
 Grille Finish = Desert Sand,
 Grille Pattern = Colonial,
 Number of Squares Wide - Top = 2,
 Number of Squares Wide - Bottom = 2,
 Number of Squares High - Top = 2,
 Number of Squares High - Bottom = 2
 Jamb Liner = Tan Jamb Liner,
 Secondary Vent Stop / Sash Limiter = No Window Opening Control Device
 U-Factor = 0.25,
 Solar Heat Gain Coefficient = 0.19,
 Visible Light Transmittance = 0.45,
 Condensation Resistance = 45,
 CPD# = JEL-N-850-01686-00001
 Is this a Reorder? = No
 Manufacturer = JELD-WEN, Rantoul(IL),
 Catalog Version Date = 07/29/2021,
 Catalog Version = 21.2.23.5
 5/8" Flat Grilles Between Glass (GBG),
 Colonial,
 2W2H

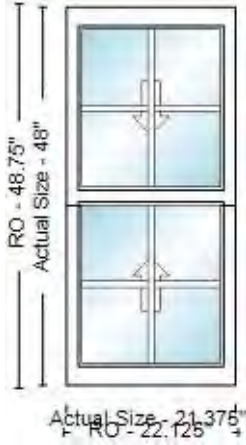

Line Item	Quantity	Product Description	Unit Price	Total Price
-----------	----------	---------------------	------------	-------------

700-1	2	Clad W-2500, Direct Set,	\$731.80	\$1,463.60
-------	---	-----------------------------	----------	------------

Rough Opening: 18.5 x 59

Actual Size: 17.75 x 58.25

Room: 1st back closet
Unit is viewed from the outside looking in.

ProductTileBackendName = JELD-WEN W-2500 Clad Picture
 Assembly = Full Unit,
 Exterior Trim Type = Nailing Flange removed (Block frame),
 Exterior Trim Options = No,
 Country Where Unit Will Be Installed = USA (Certified)
 Measurement Type = Actual Size,
 Frame Width = Custom Size,
 Custom Frame Width = 17.75,
 Frame Height = Custom Size,
 Custom Frame Height = 58.25
 Interior Material Type = Auralast Pine,
 Interior Finish Type = Painted,
 Interior Finish = Paint Desert Sand,
 Exterior Finish = Desert Sand
 Extension Jamb = 4 9/16",
 Thickness of extension jamb material = (Standard) 9/16 " Thick Jamb Extension
 Performance Grade Rating = PG 35
 Glass Energy Efficiency = Energy Star,
 Installation Zip Code = 48203,
 Energy Star Zone = Energy Star - Northern,
 Energy Star Low-E Options = Low-E EC 366 (i89 In/366 Out),
 Glass Type = Standard,
 Neat Glass = No,
 Glass Thickness = Standard Default Thickness,
 Protective Film = No Protective Film,
 Glass Spacer Color = Black Spacer,
 Air Space Options = Argon
 Grille Type = No Grilles
 U-Factor = 0.22,
 Solar Heat Gain Coefficient = 0.23,
 Visible Light Transmittance = 0.55,
 Condensation Resistance = 45,
 CPD# = JEL-N-889-03292-00001
 Is this a Reorder? = No
 Manufacturer = JELD-WEN, Rantoul(IL),
 Catalog Version Date = 07/29/2021,
 Catalog Version = 21.2.23.5
 None

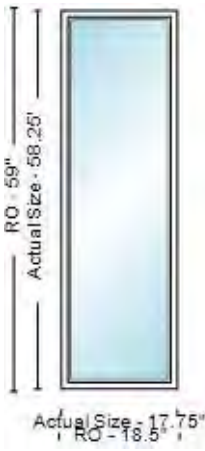
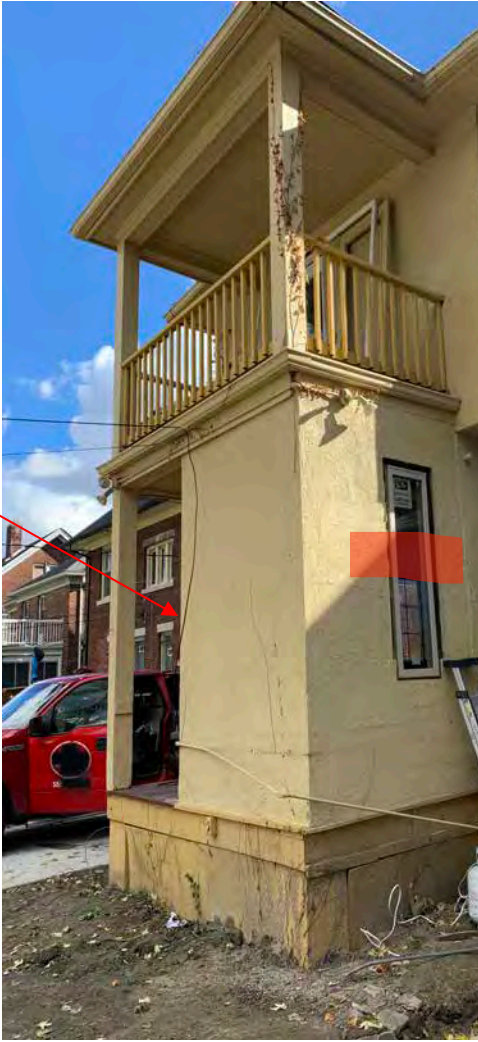

Line Item	Quantity	Product Description	Unit Price	Total Price
-----------	----------	---------------------	------------	-------------

800-1	1	Clad W-5500, Double Slider, 47.3125 x 47.5625	\$1,055.84	\$1,055.84
-------	---	---	------------	------------

Rough Opening: 48.0625 x 48.3125

Actual Size: 47.3125 x 47.5625

Room: 1st back room slider
Unit is viewed from the outside looking in.

ProductTileBackendName = JELD-WEN W-5500 Clad Double Slider
 Assembly = Full Unit,
 Exterior Trim Type = Nailing Flange removed (Block frame),
 Country Where Unit Will Be Installed = USA (Certified),
 Unit Operation = Left Hand Unit,
 Operation = 2 Panel
 Measurement Type = Actual Size,
 Frame Width = 47 5/16",
 Frame Height = 47 9/16"
 Interior Material Type = Auralast Pine,
 Interior Finish Type = Painted,
 Interior Finish = Paint Desert Sand,
 Exterior Finish = Desert Sand,
 Sash to Match Exterior Frame Finish = Yes,
 Exterior Sash Finish = Desert Sand
 Extension Jamb = 4 9/16"
 Performance Grade Rating = PG 30
 Hardware Finish = Desert Sand,
 Number of Locks = 2,
 Screen Options = BetterVue Mesh (Standard),
 Screen Frame Finish = Desert Sand
 Glass Energy Efficiency = Energy Star,
 Installation Zip Code = 48206,
 Energy Star Zone = Energy Star - Northern,
 Energy Star Low-E Options = Low-E EC 366 (i89 In/366 Out),
 Glass Type = Standard,
 Neat Glass = No,
 Glass Thickness = Standard Default Thickness,
 Protective Film = Protective Film,
 Glass Spacer Color = Black Spacer,
 Air Space Options = Argon,
 Glazing Stop Style = Standard
 Grille Type = 5/8" Flat GBG,
 Grille Location in Glass = All Lite(s),
 Grille Finish = Desert Sand,
 Grille Pattern = Colonial,
 Number of Squares Wide - Left/Right = 2,
 Number of Squares High = 3
 U-Factor = 0.27,
 Solar Heat Gain Coefficient = 0.18,
 Visible Light Transmittance = 0.42,
 Condensation Resistance = 47,
 CPD# = JEL-N-338-00906-00001
 Is this a Reorder? = No
 Manufacturer = JELD-WEN, Rantoul(IL),
 Catalog Version Date = 07/29/2021,
 Catalog Version = 21.2.23.5
 5/8" Flat Grilles Between Glass (GBG),
 Colonial,
 2W3H

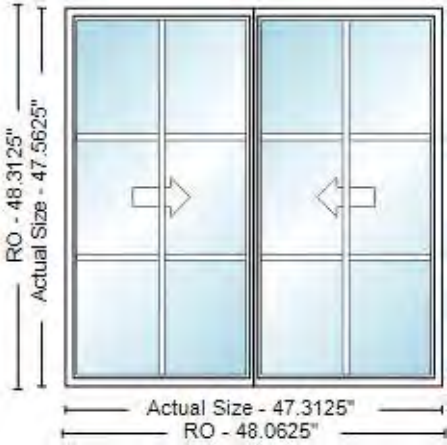
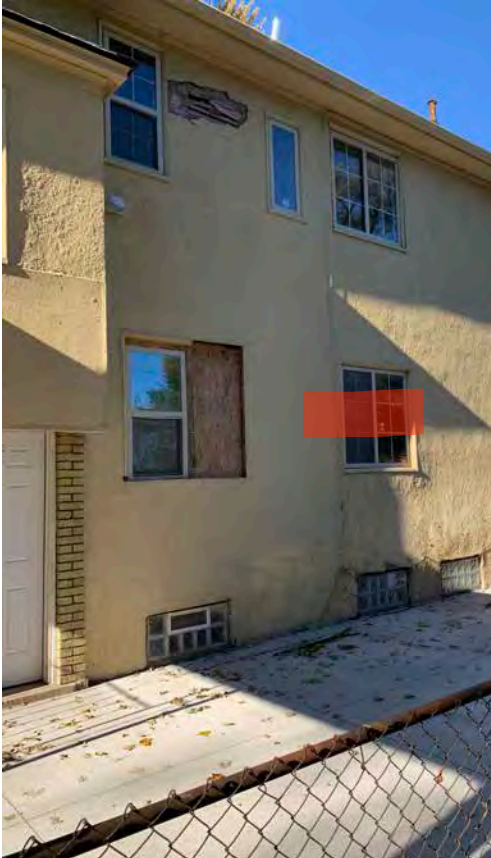

900-1

Line Item	Quantity	Product Description	Unit Price	Total Price
-----------	----------	---------------------	------------	-------------

1000-1	1	Clad W-2500, Double Hung,	\$712.75	\$712.75
--------	---	------------------------------	----------	----------

Rough Opening: 22.125 x 48.75

21.375 x 48

Actual Size: 21.375 x 48

Room: 2nd floor laundry
Unit is viewed from the outside looking in.



ProductTileBackendName = JELD-WEN W-2500 Clad Double Hung
 Assembly = Full Unit,
 Sash Model = Standard,
 Exterior Trim Type = Nailing Flange removed (Block frame),
 Exterior Trim Options = No,
 Country Where Unit Will Be Installed = USA (Certified)
 Sash Split = Even Divide,
 Measurement Type = Actual Size,
 Frame Width = 21 3/8",
 Frame Height = 48"
 Interior Material Type = Auralast Pine,
 Interior Finish Type = Painted,
 Interior Finish = Paint Desert Sand,
 Exterior Finish = Desert Sand,
 Sash to Match Exterior Frame Finish = Yes,
 Exterior Sash Finish = Desert Sand
 Extension Jamb = 4 9/16"
 Performance Grade Rating = PG 35
 Hardware Finish = Desert Sand,
 Number of Locks = 1,
 Screen Options = BetterVue Mesh (Standard),
 Screen Frame Finish = Desert Sand
 Glass Energy Efficiency = Energy Star,
 Installation Zip Code = 48203,
 Energy Star Zone = Energy Star - Northern,
 Energy Star Low-E Options = Low-E EC 366 (i89 In/366 Out),
 Glass Type = Standard,
 Neat Glass = No,
 Glass Thickness = Standard Default Thickness,
 Protective Film = No Protective Film,
 Glass Spacer Color = Black Spacer,
 Air Space Options = Argon
 Grille Type = 5/8" Flat GBG,
 Grille Location in Glass = All Lite(s),
 Grille Finish = Desert Sand,
 Grille Pattern = Colonial,
 Number of Squares Wide - Top = 2,
 Number of Squares Wide - Bottom = 2,
 Number of Squares High - Top = 2,
 Number of Squares High - Bottom = 2
 Jamb Liner = Tan Jamb Liner,
 Secondary Vent Stop / Sash Limiter = No Window Opening Control Device
 U-Factor = 0.25,
 Solar Heat Gain Coefficient = 0.19,
 Visible Light Transmittance = 0.45,
 Condensation Resistance = 45,
 CPD# = JEL-N-850-01686-00001
 Is this a Reorder? = No
 Manufacturer = JELD-WEN, Rantoul(IL),
 Catalog Version Date = 07/29/2021,
 Catalog Version = 21.2.23.5
 5/8" Flat Grilles Between Glass (GBG),
 Colonial,
 2W2H

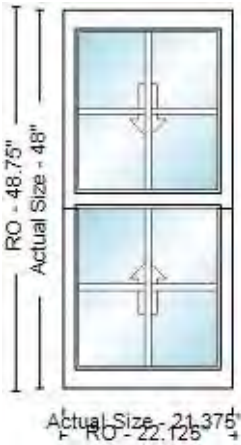

Line Item	Quantity	Product Description	Unit Price	Total Price
-----------	----------	---------------------	------------	-------------

1100-1	1	Clad W-2500, Direct Set,	\$738.31	\$738.31
--------	---	-----------------------------	----------	----------

Rough Opening: 17.5 x 41.25

16.75 x 40.5

Actual Size: 16.75 x 40.5

Room: 2nd floor backroom
Unit is viewed from the outside looking in.



ProductTileBackendName = JELD-WEN W-2500 Clad Picture
 Assembly = Full Unit,
 Exterior Trim Type = Nailing Flange removed (Block frame),
 Exterior Trim Options = No,
 Country Where Unit Will Be Installed = USA (Certified)
 Measurement Type = Actual Size,
 Frame Width = Custom Size,
 Custom Frame Width = 16.75,
 Frame Height = Custom Size,
 Custom Frame Height = 40.5
 Interior Material Type = Auralast Pine,
 Interior Finish Type = Painted,
 Interior Finish = Paint Desert Sand,
 Exterior Finish = Desert Sand
 Extension Jamb = 4 9/16",
 Thickness of extension jamb material = (Standard) 9/16 " Thick Jamb Extension
 Performance Grade Rating = PG 35
 Glass Energy Efficiency = Energy Star,
 Installation Zip Code = 48203,
 Energy Star Zone = Energy Star - Northern,
 Energy Star Low-E Options = Low-E EC 366 (i89 In/366 Out),
 Glass Type = Standard,
 Neat Glass = No,
 Glass Thickness = Standard Default Thickness,
 Protective Film = No Protective Film,
 Glass Spacer Color = Black Spacer,
 Air Space Options = Argon
 Grille Type = No Grilles
 U-Factor = 0.22,
 Solar Heat Gain Coefficient = 0.23,
 Visible Light Transmittance = 0.55,
 Condensation Resistance = 45,
 CPD# = JEL-N-889-03292-00001
 Is this a Reorder? = No
 Manufacturer = JELD-WEN, Rantoul(IL),
 Catalog Version Date = 07/29/2021,
 Catalog Version = 21.2.23.5
 None

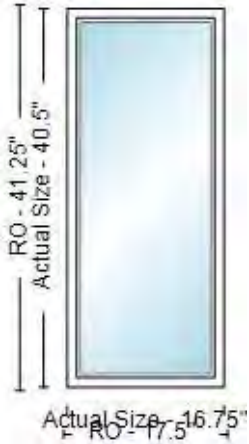

Line Item	Quantity	Product Description	Unit Price	Total Price
-----------	----------	---------------------	------------	-------------

1200-1	2	Clad W-5500, Double Slider,	\$1,055.84	\$2,111.68
--------	---	--------------------------------	------------	------------

Rough Opening: 48.0625 x 48.3125

47.3125 x 47.5625

Actual Size: 47.3125 x 47.5625

Room: 2nd floor back room
Unit is viewed from the outside looking in.

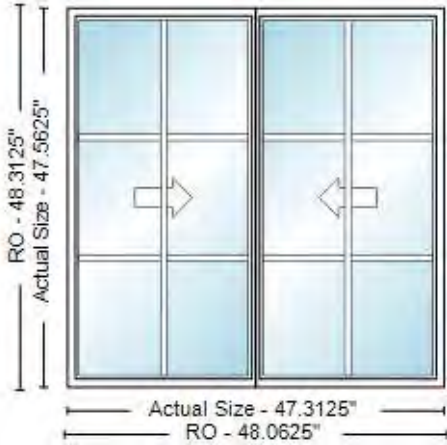

ProductTileBackendName = JELD-WEN W-5500 Clad Double Slider
 Assembly = Full Unit,
 Exterior Trim Type = Nailing Flange removed (Block frame),
 Country Where Unit Will Be Installed = USA (Certified),
 Unit Operation = Left Hand Unit,
 Operation = 2 Panel
 Measurement Type = Actual Size,
 Frame Width = 47 5/16",
 Frame Height = 47 9/16"
 Interior Material Type = Auralast Pine,
 Interior Finish Type = Painted,
 Interior Finish = Paint Desert Sand,
 Exterior Finish = Desert Sand,
 Sash to Match Exterior Frame Finish = Yes,
 Exterior Sash Finish = Desert Sand
 Extension Jamb = 4 9/16"
 Performance Grade Rating = PG 30
 Hardware Finish = Desert Sand,
 Number of Locks = 2,
 Screen Options = BetterVue Mesh (Standard),
 Screen Frame Finish = Desert Sand
 Glass Energy Efficiency = Energy Star,
 Installation Zip Code = 48206,
 Energy Star Zone = Energy Star - Northern,
 Energy Star Low-E Options = Low-E EC 366 (i89 In/366 Out),
 Glass Type = Standard,
 Neat Glass = No,
 Glass Thickness = Standard Default Thickness,
 Protective Film = Protective Film,
 Glass Spacer Color = Black Spacer,
 Air Space Options = Argon,
 Glazing Stop Style = Standard
 Grille Type = 5/8" Flat GBG,
 Grille Location in Glass = All Lite(s),
 Grille Finish = Desert Sand,
 Grille Pattern = Colonial,
 Number of Squares Wide - Left/Right = 2,
 Number of Squares High = 3
 U-Factor = 0.27,
 Solar Heat Gain Coefficient = 0.18,
 Visible Light Transmittance = 0.42,
 Condensation Resistance = 47,
 CPD# = JEL-N-338-00906-00001
 Is this a Reorder? = No
 Manufacturer = JELD-WEN, Rantoul(IL),
 Catalog Version Date = 07/29/2021,
 Catalog Version = 21.2.23.5
 5/8" Flat Grilles Between Glass (GBG),
 Colonial,
 2W3H

Line Item	Quantity	Product Description	Unit Price	Total Price
-----------	----------	---------------------	------------	-------------

1300-1	1	Clad W-2500, Double Hung, 25.375 x 48	\$831.32	\$831.32
--------	---	---	----------	----------

Rough Opening: 26.125 x 48.75

Actual Size: 25.375 x 48

Room: 1st Back Room
Unit is viewed from the outside looking in.

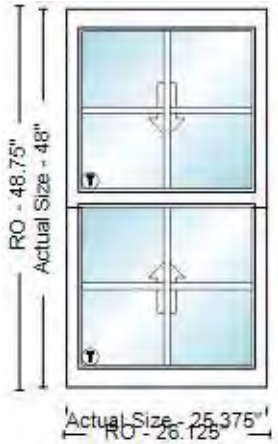

ProductTileBackendName = JELD-WEN W-2500 Clad Double Hung
 Assembly = Full Unit,
 Sash Model = Standard,
 Exterior Trim Type = Nailing Flange removed (Block frame),
 Exterior Trim Options = No,
 Country Where Unit Will Be Installed = USA (Certified)
 Sash Split = Even Divide,
 Measurement Type = Actual Size,
 Frame Width = 25 3/8",
 Frame Height = 48"
 Interior Material Type = Auralast Pine,
 Interior Finish Type = Painted,
 Interior Finish = Paint Desert Sand,
 Exterior Finish = Desert Sand,
 Sash to Match Exterior Frame Finish = Yes,
 Exterior Sash Finish = Desert Sand
 Extension Jamb = 4 9/16"
 Performance Grade Rating = PG 35
 Hardware Finish = Desert Sand,
 Number of Locks = 1,
 Screen Options = BetterVue Mesh (Standard),
 Screen Frame Finish = Desert Sand
 Glass Energy Efficiency = Energy Star,
 Installation Zip Code = 48203,
 Energy Star Zone = Energy Star - Northern,
 Energy Star Low-E Options = Low-E EC 366 (i89 In/366 Out),
 Glass Type = Tempered,
 Neat Glass = No,
 Glass Thickness = Standard Default Thickness,
 California Urban Fire Code Label = No,
 Protective Film = No Protective Film,
 Glass Spacer Color = Black Spacer,
 Air Space Options = Argon
 Grille Type = 5/8" Flat GBG,
 Grille Location in Glass = All Lite(s),
 Grille Finish = Desert Sand,
 Grille Pattern = Colonial,
 Number of Squares Wide - Top = 2,
 Number of Squares Wide - Bottom = 2,
 Number of Squares High - Top = 2,
 Number of Squares High - Bottom = 2
 Jamb Liner = Tan Jamb Liner,
 Secondary Vent Stop / Sash Limiter = No Window Opening Control Device
 U-Factor = 0.26,
 Solar Heat Gain Coefficient = 0.19,
 Visible Light Transmittance = 0.44,
 Condensation Resistance = 43,
 CPD# = JEL-N-850-01754-00001
 Is this a Reorder? = No
 Manufacturer = JELD-WEN, Rantoul(IL),
 Catalog Version Date = 07/29/2021,
 Catalog Version = 21.2.23.5
 5/8" Flat Grilles Between Glass (GBG),
 Colonial,
 2W2H

Line Item	Quantity	Product Description	Unit Price	Total Price
-----------	----------	---------------------	------------	-------------

1500-1	2	Clad W-2500, Double Hung,	\$712.75	\$1,425.50
--------	---	------------------------------	----------	------------

Rough Opening: 22.125 x 48.75

21.375 x 48

Actual Size: 21.375 x 48

Room: 2nd floor front left room
Unit is viewed from the outside looking in.

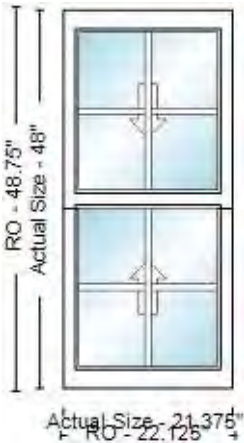

ProductTileBackendName = JELD-WEN W-2500 Clad Double Hung
 Assembly = Full Unit,
 Sash Model = Standard,
 Exterior Trim Type = Nailing Flange removed (Block frame),
 Exterior Trim Options = No,
 Country Where Unit Will Be Installed = USA (Certified)
 Sash Split = Even Divide,
 Measurement Type = Actual Size,
 Frame Width = 21 3/8",
 Frame Height = 48"
 Interior Material Type = Auralast Pine,
 Interior Finish Type = Painted,
 Interior Finish = Paint Desert Sand,
 Exterior Finish = Desert Sand,
 Sash to Match Exterior Frame Finish = Yes,
 Exterior Sash Finish = Desert Sand
 Extension Jamb = 4 9/16"
 Performance Grade Rating = PG 35
 Hardware Finish = Desert Sand,
 Number of Locks = 1,
 Screen Options = BetterVue Mesh (Standard),
 Screen Frame Finish = Desert Sand
 Glass Energy Efficiency = Energy Star,
 Installation Zip Code = 48203,
 Energy Star Zone = Energy Star - Northern,
 Energy Star Low-E Options = Low-E EC 366 (i89 In/366 Out),
 Glass Type = Standard,
 Neat Glass = No,
 Glass Thickness = Standard Default Thickness,
 Protective Film = No Protective Film,
 Glass Spacer Color = Black Spacer,
 Air Space Options = Argon
 Grille Type = 5/8" Flat GBG,
 Grille Location in Glass = All Lite(s),
 Grille Finish = Desert Sand,
 Grille Pattern = Colonial,
 Number of Squares Wide - Top = 2,
 Number of Squares Wide - Bottom = 2,
 Number of Squares High - Top = 2,
 Number of Squares High - Bottom = 2
 Jamb Liner = Tan Jamb Liner,
 Secondary Vent Stop / Sash Limiter = No Window Opening Control Device
 U-Factor = 0.25,
 Solar Heat Gain Coefficient = 0.19,
 Visible Light Transmittance = 0.45,
 Condensation Resistance = 45,
 CPD# = JEL-N-850-01686-00001
 Is this a Reorder? = No
 Manufacturer = JELD-WEN, Rantoul(IL),
 Catalog Version Date = 07/29/2021,
 Catalog Version = 21.2.23.5
 5/8" Flat Grilles Between Glass (GBG),
 Colonial,
 2W2H

Line Item	Quantity	Product Description	Unit Price	Total Price
-----------	----------	---------------------	------------	-------------

1600-1	2	Clad W-5500, Double Slider, 47.3125 x 47.5625	\$1,055.84	\$2,111.68
--------	---	---	------------	------------

Rough Opening: 48.0625 x 48.3125

Actual Size: 47.3125 x 47.5625

Room: 2nd floor master bedroom closet
Unit is viewed from the outside looking in.



ProductTileBackendName = JELD-WEN W-5500 Clad Double Slider
 Assembly = Full Unit,
 Exterior Trim Type = Nailing Flange removed (Block frame),
 Country Where Unit Will Be Installed = USA (Certified),
 Unit Operation = Left Hand Unit,
 Operation = 2 Panel
 Measurement Type = Actual Size,
 Frame Width = 47 5/16",
 Frame Height = 47 9/16"
 Interior Material Type = Auralast Pine,
 Interior Finish Type = Painted,
 Interior Finish = Paint Desert Sand,
 Exterior Finish = Desert Sand,
 Sash to Match Exterior Frame Finish = Yes,
 Exterior Sash Finish = Desert Sand
 Extension Jamb = 4 9/16"
 Performance Grade Rating = PG 30
 Hardware Finish = Desert Sand,
 Number of Locks = 2,
 Screen Options = BetterVue Mesh (Standard),
 Screen Frame Finish = Desert Sand
 Glass Energy Efficiency = Energy Star,
 Installation Zip Code = 48206,
 Energy Star Zone = Energy Star - Northern,
 Energy Star Low-E Options = Low-E EC 366 (i89 In/366 Out),
 Glass Type = Standard,
 Neat Glass = No,
 Glass Thickness = Standard Default Thickness,
 Protective Film = Protective Film,
 Glass Spacer Color = Black Spacer,
 Air Space Options = Argon,
 Glazing Stop Style = Standard
 Grille Type = 5/8" Flat GBG,
 Grille Location in Glass = All Lite(s),
 Grille Finish = Desert Sand,
 Grille Pattern = Colonial,
 Number of Squares Wide - Left/Right = 2,
 Number of Squares High = 3
 U-Factor = 0.27,
 Solar Heat Gain Coefficient = 0.18,
 Visible Light Transmittance = 0.42,
 Condensation Resistance = 47,
 CPD# = JEL-N-338-00906-00001
 Is this a Reorder? = No
 Manufacturer = JELD-WEN, Rantoul(IL),
 Catalog Version Date = 07/29/2021,
 Catalog Version = 21.2.23.5
 5/8" Flat Grilles Between Glass (GBG),
 Colonial,
 2W3H

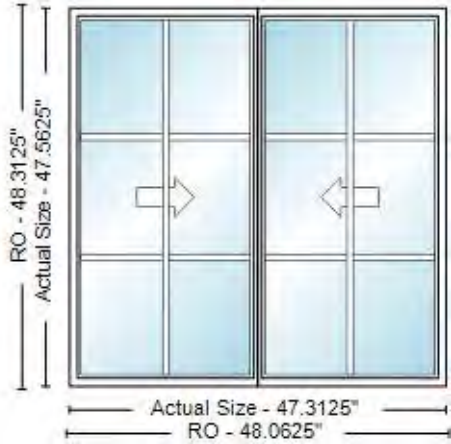

Line Item	Quantity	Product Description	Unit Price	Total Price
-----------	----------	---------------------	------------	-------------

1800-1	3	Clad W-2500, Double Hung,	\$851.43	\$2,554.29
--------	---	------------------------------	----------	------------

Rough Opening: 26.125 x 48.75

25.375 x 48

Actual Size: 25.375 x 48

Room: 2nd floor master bedroom

Unit is viewed from the outside looking in.

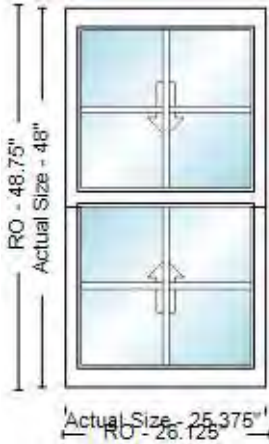

ProductTileBackendName = JELD-WEN W-2500 Clad Double Hung
 Assembly = Full Unit,
 Sash Model = Standard,
 Exterior Trim Type = Nailing Flange removed (Block frame),
 Exterior Trim Options = No,
 Country Where Unit Will Be Installed = USA (Certified)
 Sash Split = Even Divide,
 Measurement Type = Actual Size,
 Frame Width = 25 3/8",
 Frame Height = 48"
 Interior Material Type = Auralast Pine,
 Interior Finish Type = Painted,
 Interior Finish = Paint Desert Sand,
 Exterior Finish = Desert Sand,
 Sash to Match Exterior Frame Finish = Yes,
 Exterior Sash Finish = Desert Sand
 Extension Jamb = 4 9/16"
 Performance Grade Rating = PG 35
 Hardware Finish = Desert Sand,
 Number of Locks = 1,
 Screen Options = BetterVue Mesh (Standard),
 Screen Frame Finish = Desert Sand
 Glass Energy Efficiency = Energy Star,
 Installation Zip Code = 48203,
 Energy Star Zone = Energy Star - Northern,
 Energy Star Low-E Options = Low-E EC 366 (i89 In/366 Out),
 Glass Type = Standard,
 Neat Glass = No,
 Glass Thickness = Standard Default Thickness,
 Protective Film = No Protective Film,
 Glass Spacer Color = Black Spacer,
 Air Space Options = Argon
 Grille Type = 5/8" Flat GBG,
 Grille Location in Glass = All Lite(s),
 Grille Finish = Desert Sand,
 Grille Pattern = Colonial,
 Number of Squares Wide - Top = 2,
 Number of Squares Wide - Bottom = 2,
 Number of Squares High - Top = 2,
 Number of Squares High - Bottom = 2
 Jamb Liner = Tan Jamb Liner,
 Secondary Vent Stop / Sash Limiter = No Window Opening Control Device
 U-Factor = 0.25,
 Solar Heat Gain Coefficient = 0.19,
 Visible Light Transmittance = 0.45,
 Condensation Resistance = 45,
 CPD# = JEL-N-850-01686-00001
 Is this a Reorder? = No
 Manufacturer = JELD-WEN, Rantoul(IL),
 Catalog Version Date = 07/29/2021,
 Catalog Version = 21.2.23.5
 5/8" Flat Grilles Between Glass (GBG),
 Colonial,
 2W2H

1900

Line Item	Quantity	Product Description	Unit Price	Total Price
-----------	----------	---------------------	------------	-------------

900-1 2 Clad W-2500,
Direct Set, \$1,013.61 \$2,027.22

Rough Opening: 47.75 x 48.25

Actual Size: 47 x 47.5

Room: stair case tempered
Unit is viewed from the outside looking in.

Product Backend Name = JELD-WEN W-2500 Clad Picture
 Assembly = Full Unit,
 Exterior Trim Type = Nailing Flange removed (Block frame),
 Exterior Trim Options = No,
 Country Where Unit Will Be Installed = USA (Certified)
 Measurement Type = Actual Size,
 Frame Width = Custom Size,
 Custom Frame Width = 47,
 Frame Height = Custom Size,
 Custom Frame Height = 47.5
 Interior Material Type = Auralast Pine,
 Interior Finish Type = Painted,
 Interior Finish = Paint Desert Sand,
 Exterior Finish = Desert Sand
 Extension Jamb = 4 9/16",
 Thickness of extension jamb material = (Standard) 9/16" Thick Jamb Extension
 Performance Grade Rating = PG 35
 Glass Energy Efficiency = Energy Star,
 Installation Zip Code = 48203,
 Energy Star Zone = Energy Star - Northern,
 Energy Star Low-E Options = Low-E EC 366 (i89 In/366 Out),
 Glass Type = Tempered,
 Neat Glass = No,
 Glass Thickness = Standard Default Thickness,
 California Urban Fire Code Label = No,
 Protective Film = No Protective Film,
 Glass Spacer Color = Black Spacer,
 Air Space Options = Argon
 Grille Type = No Grilles
 U-Factor = 0.22,
 Solar Heat Gain Coefficient = 0.23,
 Visible Light Transmittance = 0.54,
 Condensation Resistance = 45,
 CPD# = JEL-N-889-03522-00001
 Is this a Reorder? = No
 Manufacturer = JELD-WEN, Rantoul(IL),
 Catalog Version Date = 07/29/2021,
 Catalog Version = 21.2.23.5
 None

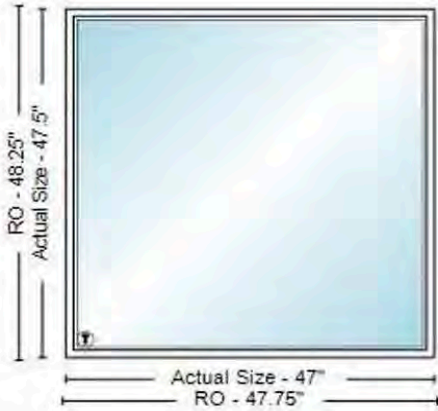

Total: \$30,608.30

Special Order Quote

Customer Agreement #: H2710-198747

Printed Date: 11/29/2021

Customer: KRISTYN PATTERSON

Address: 2522 W BOSTON BLVD
DETROIT, MI 48206

Phone 1: 773-551-0027

Phone 2:

Email: kpgproperties@gmail.com

Store: 2710

Associate: FOUAD

Address: 25451 MICHIGAN AVENUE
DEARBORN HEIGHTS, MI
48125

Phone: 313-359-9600

Pre-Savings Total: \$11,059.40

Total Savings: (\$1,659.56)

Pre-Tax Price: \$9,399.84

Price Valid Through:
1/17/2021

All prices are subject to change. Customer is responsible for verifying product selections. The Home Depot will not accept returns for the below products.



Frame Width = 22 3/4

Frame Height = 48 1/4

Line Number	Item Summary	Was Price	Now Price	Quantity	Total Savings	Total Price
100-1	50 Series Buck Single-Hung-2001 Equal Sash , Fixed/Active , 22.75 x 48.25 , Beige / Beige	\$232.97	\$198.00	1	(\$34.97)	\$198.00
Unit 100 Total:		\$232.97	\$198.00		(\$34.97)	\$198.00

Begin Line 100 Description

---- Line 100-1 ----

50 Series Buck Single-Hung-2001
Overall Rough Opening = 23" x 48 3/4"
Overall Unit = 22 3/4" x 48 1/4"
Installation Zip Code = 48206
U.S. ENERGY STAR® Climate Zone = Northern
ENERGY STAR Required = Yes
Frame Width = 22 3/4
Frame Height = 48 1/4
Venting / Handing = Fixed/Active
Exterior Color = Beige
Interior Finish Color = Beige
Performance Rating = PG35 / DP 35/35
Glass Construction Type = Dual Pane
Glass Option = Low-E2+ PS

High Altitude Breather Tubes = No
Glass Strength = Standard
Glass Tint = No Tint
Specialty Glass = None
Gas Fill = Air
Contour Grilles-Between-the-Glass
Colonial
Grille Pattern = Colonial
Exterior Grille Color = Beige
Interior Grille Color = Beige
2W2H
Number of Sash Locks = Single
Lock Type = Standard
Insect Screen Type = Half Screen

Insect Screen Material = Fiberglass
Vinyl Sill Angle = Sill Angle
Head Expander = Yes
Room Location = bedroom 1,
Is this a Remake? = No
Re-Order Item = No
Unit U-Factor = 0.28
Unit Solar Heat Gain Coefficient (SHGC) = 0.34
U.S. ENERGY STAR Certified = Yes
SKU = 238843
Vendor Name = S/O SILVER LINE BLDG PRD
Vendor Number = 60660514
Customer Service = (888) 504-0005
Catalog Version Date = 01/04/2021

End Line 100 Description



Frame Width = 47

Frame Height = 48 1/2

Line Number	Item Summary	Was Price	Now Price	Quantity	Total Savings	Total Price
200-1	50 Series Buck Single Gliding-2092 , Active/Stationary (XO) , 47 x 48.5 , Beige / Beige	\$257.38	\$218.75	1	(\$38.63)	\$218.75
Unit 200 Total:		\$257.38	\$218.75		(\$38.63)	\$218.75

Begin Line 200 Description

---- Line 200-1 ----

<p>50 Series Buck Single Gliding-2092 Overall Rough Opening = 47 1/4" x 49" Overall Unit = 47" x 48 1/2" Installation Zip Code = 48206 U.S. ENERGY STAR® Climate Zone = Northern ENERGY STAR Required = Yes Frame Width = 47 Frame Height = 48 1/2 Venting / Handing = Active/Stationary (XO) Exterior Color = Beige Interior Finish Color = Beige Performance Rating = PG15 / DP 15/15 Glass Construction Type = Dual Pane Glass Option = Low-E PS Argon High Altitude Breather Tubes = No</p>	<p>Glass Strength = Standard Glass Tint = No Tint Specialty Glass = None Gas Fill = Argon Contour Grilles-Between-the-Glass Colonial Grille Pattern = Colonial Exterior Grille Color = Beige Interior Grille Color = Beige 2W3H Hardware = Standard Hardware Color/Finish = Beige Number of Sash Locks = Double Lock Type = Standard Insect Screen Type = Half Screen</p>	<p>Insect Screen Material = Fiberglass Vinyl Sill Angle = Sill Angle Head Expander = Yes Room Location = Bedroom 1, Is this a Remake? = No Re-Order Item = No Unit U-Factor = 0.29 Unit Solar Heat Gain Coefficient (SHGC) = 0.42 U.S. ENERGY STAR Certified = Yes SKU = 238843 Vendor Name = S/O SILVER LINE BLDG PRD Vendor Number = 60660514 Customer Service = (888) 504-0005 Catalog Version Date = 01/04/2021</p>
---	---	--

End Line 200 Description



Frame Width = 47
Frame Height = 48 1/2

Line Number	Item Summary	Was Price	Now Price	Quantity	Total Savings	Total Price
300-1	50 Series Buck Single Gliding-2092 , Active/Stationary (XO) , 47 x 48.5 , Beige / Beige	\$257.38	\$218.75	2	(\$77.26)	\$437.50
Unit 300 Total:		\$257.38	\$218.75		(\$77.26)	\$437.50

Begin Line 300 Description

---- Line 300-1 ----

<p>50 Series Buck Single Gliding-2092 Overall Rough Opening = 47 1/4" x 49" Overall Unit = 47" x 48 1/2" Installation Zip Code = 48206 U.S. ENERGY STAR® Climate Zone = Northern ENERGY STAR Required = Yes Frame Width = 47 Frame Height = 48 1/2 Venting / Handing = Active/Stationary (XO) Exterior Color = Beige Interior Finish Color = Beige Performance Rating = PG15 / DP 15/15 Glass Construction Type = Dual Pane Glass Option = Low-E PS Argon High Altitude Breather Tubes = No</p>	<p>Glass Strength = Standard Glass Tint = No Tint Specialty Glass = None Gas Fill = Argon Contour Grilles-Between-the-Glass Colonial Grille Pattern = Colonial Exterior Grille Color = Beige Interior Grille Color = Beige 2W3H Hardware = Standard Hardware Color/Finish = Beige Number of Sash Locks = Double Lock Type = Standard Insect Screen Type = Half Screen</p>	<p>Insect Screen Material = Fiberglass Vinyl Sill Angle = Sill Angle Head Expander = Yes Room Location = master closet, Is this a Remake? = No Re-Order Item = No Unit U-Factor = 0.29 Unit Solar Heat Gain Coefficient (SHGC) = 0.42 U.S. ENERGY STAR Certified = Yes SKU = 238843 Vendor Name = S/O SILVER LINE BLDG PRD Vendor Number = 60660514 Customer Service = (888) 504-0005 Catalog Version Date = 01/04/2021</p>
---	---	--

End Line 300 Description



Frame Width = 23
Frame Height = 48 1/4

Line Number	Item Summary	Was Price	Now Price	Quantity	Total Savings	Total Price
400-1	50 Series Buck Single-Hung-2001 Equal Sash , Fixed/Active , 23 x 48.25 , Beige / Beige	\$265.23	\$225.44	2	(\$79.58)	\$450.88
Unit 400 Total:		\$265.23	\$225.44		(\$79.58)	\$450.88

Begin Line 400 Description

---- Line 400-1 ----

50 Series Buck Single-Hung-2001	Glass Option = Low-E2+ PS	Head Expander = Yes
Overall Rough Opening = 23 1/4" x 48 3/4"	High Altitude Breather Tubes = No	Room Location = Master bathroom,
Overall Unit = 23" x 48 1/4"	Glass Strength = Tempered	Is this a Remake? = No
Installation Zip Code = 48206	Glass Tint = No Tint	Re-Order Item = No
U.S. ENERGY STAR® Climate Zone = Northern	Specialty Glass = None	Unit U-Factor = 0.29
ENERGY STAR Required = Yes	Gas Fill = Air	Unit Solar Heat Gain Coefficient (SHGC) = 0.37
Frame Width = 23	None	U.S. ENERGY STAR Certified = Yes
Frame Height = 48 1/4	Number of Sash Locks = Single	SKU = 238843
Venting / Handing = Fixed/Active	Lock Type = Standard	Vendor Name = S/O SILVER LINE BLDG PRD
Exterior Color = Beige	Insect Screen Type = Half Screen	Vendor Number = 60660514
Interior Finish Color = Beige	Insect Screen Material = Fiberglass	Customer Service = (888) 504-0005
Performance Rating = PG35 / DP 35/35	Vinyl Sill Angle = Sill Angle	Catalog Version Date = 01/04/2021
Glass Construction Type = Dual Pane		

End Line 400 Description



Frame Width = 23
Frame Height = 48 1/4

Line Number	Item Summary	Was Price	Now Price	Quantity	Total Savings	Total Price
500-1	50 Series Buck Single-Hung-2001 Equal Sash , Fixed/Active , 23 x 48.25 , Beige / Beige	\$233.07	\$198.10	3	(\$104.91)	\$594.30
Unit 500 Total:		\$233.07	\$198.10		(\$104.91)	\$594.30

Begin Line 500 Description

---- Line 500-1 ----

50 Series Buck Single-Hung-2001	High Altitude Breather Tubes = No	Insect Screen Material = Fiberglass
Overall Rough Opening = 23 1/4" x 48 3/4"	Glass Strength = Standard	Vinyl Sill Angle = Sill Angle
Overall Unit = 23" x 48 1/4"	Glass Tint = No Tint	Head Expander = Yes
Installation Zip Code = 48206	Specialty Glass = None	Room Location = Master bedroom,
U.S. ENERGY STAR® Climate Zone = Northern	Gas Fill = Air	Is this a Remake? = No
ENERGY STAR Required = Yes	Contour Grilles-Between-the-Glass	Re-Order Item = No
Frame Width = 23	Colonial	Unit U-Factor = 0.28
Frame Height = 48 1/4	Grille Pattern = Colonial	Unit Solar Heat Gain Coefficient (SHGC) = 0.34
Venting / Handing = Fixed/Active	Exterior Grille Color = Beige	U.S. ENERGY STAR Certified = Yes
Exterior Color = Beige	Interior Grille Color = Beige	SKU = 238843
Interior Finish Color = Beige	2W2H	Vendor Name = S/O SILVER LINE BLDG PRD
Performance Rating = PG35 / DP 35/35	Number of Sash Locks = Single	Vendor Number = 60660514
Glass Construction Type = Dual Pane	Lock Type = Standard	Customer Service = (888) 504-0005

End Line 500 Description



Frame Width = 46 3/4
Frame Height = 48 1/4

Line Number	Item Summary	Was Price	Now Price	Quantity	Total Savings	Total Price
600-1	50 Series Buck Single Gliding-2092 , Active/Stationary (XO) , 46.75 x 48.25 , Beige / Beige	\$257.28	\$218.67	1	(\$38.61)	\$218.67
Unit 600 Total:		\$257.28	\$218.67		(\$38.61)	\$218.67

Begin Line 600 Description

---- Line 600-1 ----

<p>50 Series Buck Single Gliding-2092 Overall Rough Opening = 47" x 48 3/4" Overall Unit = 46 3/4" x 48 1/4" Installation Zip Code = 48206 U.S. ENERGY STAR® Climate Zone = Northern ENERGY STAR Required = Yes Frame Width = 46 3/4 Frame Height = 48 1/4 Venting / Handing = Active/Stationary (XO) Exterior Color = Beige Interior Finish Color = Beige Performance Rating = PG15 / DP 15/15 Glass Construction Type = Dual Pane Glass Option = Low-E PS Argon High Altitude Breather Tubes = No</p>	<p>Glass Strength = Standard Glass Tint = No Tint Specialty Glass = None Gas Fill = Argon Contour Grilles-Between-the-Glass Colonial Grille Pattern = Colonial Exterior Grille Color = Beige Interior Grille Color = Beige 2W3H Hardware = Standard Hardware Color/Finish = Beige Number of Sash Locks = Double Lock Type = Standard Insect Screen Type = Half Screen</p>	<p>Insect Screen Material = Fiberglass Vinyl Sill Angle = Sill Angle Head Expander = Yes Room Location = Master Bed, Is this a Remake? = No Re-Order Item = No Unit U-Factor = 0.29 Unit Solar Heat Gain Coefficient (SHGC) = 0.42 U.S. ENERGY STAR Certified = Yes SKU = 238843 Vendor Name = S/O SILVER LINE BLDG PRD Vendor Number = 60660514 Customer Service = (888) 504-0005 Catalog Version Date = 01/04/2021</p>
---	---	--

End Line 600 Description

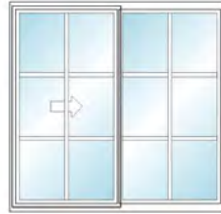

Frame Width = 48 1/4
Frame Height = 46 3/4

Line Number	Item Summary	Was Price	Now Price	Quantity	Total Savings	Total Price
700-1	50 Series Buck Single Gliding-2092 , Active/Stationary (XO) , 48.25 x 46.75 , Beige / Beige	\$257.90	\$219.19	2	(\$77.42)	\$438.38
Unit 700 Total:		\$257.90	\$219.19		(\$77.42)	\$438.38

Begin Line 700 Description

---- Line 700-1 ----

<p>50 Series Buck Single Gliding-2092 Overall Rough Opening = 48 1/2" x 47 1/4" Overall Unit = 48 1/4" x 46 3/4" Installation Zip Code = 48206 U.S. ENERGY STAR® Climate Zone = Northern ENERGY STAR Required = Yes Frame Width = 48 1/4 Frame Height = 46 3/4 Venting / Handing = Active/Stationary (XO)</p>	<p>Glass Strength = Standard Glass Tint = No Tint Specialty Glass = None Gas Fill = Argon Contour Grilles-Between-the-Glass Colonial Grille Pattern = Colonial Exterior Grille Color = Beige Interior Grille Color = Beige</p>	<p>Insect Screen Material = Fiberglass Vinyl Sill Angle = Sill Angle Head Expander = Yes Room Location = Bedroom 2, Is this a Remake? = No Re-Order Item = No Unit U-Factor = 0.29 Unit Solar Heat Gain Coefficient (SHGC) = 0.42 U.S. ENERGY STAR Certified = Yes</p>
---	--	--

Exterior Color = Beige
 Interior Finish Color = Beige
 Performance Rating = PG15 / DP 15/15
 Glass Construction Type = Dual Pane
 Glass Option = Low-E PS Argon
 High Altitude Breather Tubes = No

2W3H
 Hardware = Standard
 Hardware Color/Finish = Beige
 Number of Sash Locks = Double
 Lock Type = Standard
 Insect Screen Type = Half Screen

SKU = 238843
 Vendor Name = S/O SILVER LINE BLDG PRD
 Vendor Number = 60660514
 Customer Service = (888) 504-0005
 Catalog Version Date = 01/04/2021

End Line 700 Description



Frame Width = 16 3/4
 Frame Height = 40 1/2

Line Number	Item Summary	Was Price	Now Price	Quantity	Total Savings	Total Price
800-1	50 Series Buck Picture Window-2051 , Fixed , 16.75 x 40.5 , Beige / Beige	\$204.87	\$174.13	1	(\$30.74)	\$174.13
Unit 800 Total:		\$204.87	\$174.13		(\$30.74)	\$174.13

Begin Line 800 Description

---- Line 800-1 ----

50 Series Buck Picture Window-2051
 Overall Rough Opening = 17" x 41"
 Overall Unit = 16 3/4" x 40 1/2"
 Installation Zip Code = 48206
 U.S. ENERGY STAR® Climate Zone = Northern
 ENERGY STAR Required = Yes
 Frame Width = 16 3/4
 Frame Height = 40 1/2
 Venting / Handing = Fixed
 Exterior Color = Beige
 Interior Finish Color = Beige

Performance Rating = PG35 / DP 50/50
 Glass Construction Type = Dual Pane
 Glass Option = Low-E2+ PS
 High Altitude Breather Tubes = No
 Glass Strength = Standard
 Glass Tint = No Tint
 Specialty Glass = None
 Gas Fill = Air
 None
 Vinyl Sill Angle = Sill Angle
 Head Expander = Yes

Room Location = Bedroom 2 closet,
 Is this a Remake? = No
 Re-Order Item = No
 Unit U-Factor = 0.28
 Unit Solar Heat Gain Coefficient (SHGC) = 0.39
 U.S. ENERGY STAR Certified = Yes
 SKU = 238843
 Vendor Name = S/O SILVER LINE BLDG PRD
 Vendor Number = 60660514
 Customer Service = (888) 504-0005
 Catalog Version Date = 01/04/2021

End Line 800 Description



Frame Width = 23
 Frame Height = 48 1/4

Line Number	Item Summary	Was Price	Now Price	Quantity	Total Savings	Total Price
900-1	50 Series Buck Single-Hung-2001 Equal Sash , Fixed/Active , 23 x 48.25 , Beige / Beige	\$233.07	\$198.10	1	(\$34.97)	\$198.10
Unit 900 Total:		\$233.07	\$198.10		(\$34.97)	\$198.10

Begin Line 900 Description

---- Line 900-1 ----

50 Series Buck Single-Hung-2001
 Overall Rough Opening = 23 1/4" x 48 3/4"
 Overall Unit = 23" x 48 1/4"
 Installation Zip Code = 48206
 U.S. ENERGY STAR® Climate Zone = Northern
 ENERGY STAR Required = Yes
 Frame Width = 23
 Frame Height = 48 1/4

High Altitude Breather Tubes = No
 Glass Strength = Standard
 Glass Tint = No Tint
 Specialty Glass = None
 Gas Fill = Air
 Contour Grilles-Between-the-Glass
 Colonial
 Grille Pattern = Colonial

Insect Screen Material = Fiberglass
 Vinyl Sill Angle = Sill Angle
 Head Expander = Yes
 Room Location = Laundry room,
 Is this a Remake? = No
 Re-Order Item = No
 Unit U-Factor = 0.28
 Unit Solar Heat Gain Coefficient (SHGC) = 0.34

Venting / Handing = Fixed/Active
 Exterior Color = Beige
 Interior Finish Color = Beige
 Performance Rating = PG35 / DP 35/35
 Glass Construction Type = Dual Pane
 Glass Option = Low-E2+ PS

Exterior Grille Color = Beige
 Interior Grille Color = Beige
 2W2H
 Number of Sash Locks = Single
 Lock Type = Standard
 Insect Screen Type = Half Screen

U.S. ENERGY STAR Certified = Yes
 SKU = 238843
 Vendor Name = S/O SILVER LINE BLDG PRD
 Vendor Number = 60660514
 Customer Service = (888) 504-0005
 Catalog Version Date = 01/04/2021

End Line 900 Description



Frame Width = 43
 Frame Height = 34

Line Number	Item Summary	Was Price	Now Price	Quantity	Total Savings	Total Price
1000-1	50 Series Buck Picture Window-2051 , Fixed , 43 x 34 , Beige / Beige	\$280.45	\$238.38	1	(\$42.07)	\$238.38
Unit 1000 Total:		\$280.45	\$238.38		(\$42.07)	\$238.38

Begin Line 1000 Description

---- Line 1000-1 ----

50 Series Buck Picture Window-2051
 Overall Rough Opening = 43 1/4" x 34 1/2"
 Overall Unit = 43" x 34"
 Installation Zip Code = 48206
 U.S. ENERGY STAR® Climate Zone = Northern
 ENERGY STAR Required = Yes
 Frame Width = 43
 Frame Height = 34
 Venting / Handing = Fixed
 Exterior Color = Beige
 Interior Finish Color = Beige

Performance Rating = PG35 / DP 50/50
 Glass Construction Type = Dual Pane
 Glass Option = Low-E2+ PS
 High Altitude Breather Tubes = No
 Glass Strength = Standard
 Glass Tint = No Tint
 Specialty Glass = None
 Gas Fill = Air
 None
 Vinyl Sill Angle = Sill Angle
 Head Expander = Yes

Room Location = Stairs to Attic.,
 Is this a Remake? = No
 Re-Order Item = No
 Unit U-Factor = 0.28
 Unit Solar Heat Gain Coefficient (SHGC) = 0.39
 U.S. ENERGY STAR Certified = Yes
 SKU = 238843
 Vendor Name = S/O SILVER LINE BLDG PRD
 Vendor Number = 60660514
 Customer Service = (888) 504-0005
 Catalog Version Date = 01/04/2021

End Line 1000 Description



Frame Width = 76 1/2
 Frame Height = 38 1/4

Line Number	Item Summary	Was Price	Now Price	Quantity	Total Savings	Total Price
1100-1	50 Series Buck Triple Gliding-2093,2094 1/4 - 1/2 - 1/4 , Active/Stationary/Active (XOX) , 76.5 x 38.25 , Beige / Beige	\$445.45	\$378.61	1	(\$66.84)	\$378.61
Unit 1100 Total:		\$445.45	\$378.61		(\$66.84)	\$378.61

Begin Line 1100 Description

---- Line 1100-1 ----

50 Series Buck Triple Gliding-2093,2094
 Overall Rough Opening = 76 3/4" x 38 3/4"
 Overall Unit = 76 1/2" x 38 1/4"
 Installation Zip Code = 48206
 U.S. ENERGY STAR® Climate Zone = Northern
 ENERGY STAR Required = Yes
 Frame Width = 76 1/2

Specialty Glass = None
 Gas Fill = Argon
 Unit 1 Left Glass, 1 Right Glass: Contour Grilles-Between-the-Glass
 Unit 1 Left Glass, 1 Right Glass: Colonial
 Unit 1 Left Glass, 1 Right Glass: Grille Pattern = Colonial

Lock Type = Standard
 Insect Screen Type = Half Screen
 Insect Screen Material = Fiberglass
 Vinyl Sill Angle = Sill Angle
 Head Expander = Yes
 Room Location = Attic bedroom,
 Is this a Remake? = No

Frame Height = 38 1/4
 Venting / Handing = Active/Stationary/Active (XOX)
 Exterior Color = Beige
 Interior Finish Color = Beige
 Performance Rating = PG15 / DP 15/15
 Glass Construction Type = Dual Pane
 Glass Option = Low-E PS Argon
 High Altitude Breather Tubes = No
 Glass Strength = Standard
 Glass Tint = No Tint

Unit 1 Left Glass, 1 Right Glass: Exterior Grille
 Color = Beige
 Unit 1 Left Glass, 1 Right Glass: Interior Grille
 Color = Beige
 Unit 1 Left Glass, 1 Right Glass: 2W3H
 Unit 1 Center Glass: Contour Grilles-Between-the-Glass
 Unit 1 Center Glass: Colonial
 Unit 1 Center Glass: Grille Pattern = Colonial
 Unit 1 Center Glass: Exterior Grille Color = Beige
 Unit 1 Center Glass: Interior Grille Color = Beige
 Unit 1 Center Glass: 3W3H
 Hardware = Standard
 Hardware Color/Finish = Beige
 Number of Sash Locks = Double

Re-Order Item = No
 Unit U-Factor = 0.29
 Unit Solar Heat Gain Coefficient (SHGC) = 0.42
 U.S. ENERGY STAR Certified = Yes
 SKU = 238843
 Vendor Name = S/O SILVER LINE BLDG PRD
 Vendor Number = 60660514
 Customer Service = (888) 504-0005
 Catalog Version Date = 01/04/2021

End Line 1100 Description

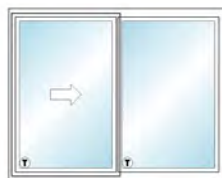

Frame Width = 43
 Frame Height = 34 1/4

Line Number	Item Summary	Was Price	Now Price	Quantity	Total Savings	Total Price
1200-1	50 Series Buck Single Gliding-2092 , Active/Stationary (XO) , 43 x 34.25 , Beige / Beige	\$293.13	\$249.15	1	(\$43.98)	\$249.15
Unit 1200 Total:		\$293.13	\$249.15		(\$43.98)	\$249.15

Begin Line 1200 Description

---- Line 1200-1 ----

50 Series Buck Single Gliding-2092
 Overall Rough Opening = 43 1/4" x 34 3/4"
 Overall Unit = 43" x 34 1/4"
 Installation Zip Code = 48206
 U.S. ENERGY STAR® Climate Zone = Northern
 ENERGY STAR Required = Yes
 Frame Width = 43
 Frame Height = 34 1/4
 Venting / Handing = Active/Stationary (XO)
 Exterior Color = Beige
 Interior Finish Color = Beige
 Performance Rating = PG15 / DP 15/15
 Glass Construction Type = Dual Pane

Glass Option = Low-E PS Argon
 High Altitude Breather Tubes = No
 Glass Strength = Tempered
 Glass Tint = No Tint
 Specialty Glass = Obscure
 Gas Fill = Argon
 None
 Hardware = Standard
 Hardware Color/Finish = Beige
 Number of Sash Locks = Double
 Lock Type = Standard
 Insect Screen Type = Half Screen
 Insect Screen Material = Fiberglass

Vinyl Sill Angle = Sill Angle
 Head Expander = Yes
 Room Location = Attic Bath,
 Is this a Remake? = No
 Re-Order Item = No
 Unit U-Factor = 0.3
 Unit Solar Heat Gain Coefficient (SHGC) = 0.46
 U.S. ENERGY STAR Certified = Yes
 SKU = 238843
 Vendor Name = S/O SILVER LINE BLDG PRD
 Vendor Number = 60660514
 Customer Service = (888) 504-0005
 Catalog Version Date = 01/04/2021

End Line 1200 Description



Frame Width = 47
 Frame Height = 47 1/2

Line Number	Item Summary	Was Price	Now Price	Quantity	Total Savings	Total Price
1300-1	50 Series Buck Picture Window-2051 , Fixed , 47 x 47.5 , Beige / Beige	\$343.55	\$291.99	1	(\$51.56)	\$291.99
Unit 1300 Total:		\$343.55	\$291.99		(\$51.56)	\$291.99

Begin Line 1300 Description

---- Line 1300-1 ----

50 Series Buck Picture Window-2051
 Overall Rough Opening = 47 1/4" x 48"
 Overall Unit = 47" x 47 1/2"
 Installation Zip Code = 48206
 U.S. ENERGY STAR® Climate Zone = Northern
 ENERGY STAR Required = Yes
 Frame Width = 47
 Frame Height = 47 1/2
 Venting / Handing = Fixed
 Exterior Color = Beige
 Interior Finish Color = Beige

Performance Rating = PG35 / DP 50/50
 Glass Construction Type = Dual Pane
 Glass Option = Low-E2+ PS
 High Altitude Breather Tubes = No
 Glass Strength = Standard
 Glass Tint = No Tint
 Specialty Glass = None
 Gas Fill = Air
 None
 Vinyl Sill Angle = Sill Angle
 Head Expander = Yes

Room Location = Stairs to 2nd floor.,
 Is this a Remake? = No
 Re-Order Item = No
 Unit U-Factor = 0.28
 Unit Solar Heat Gain Coefficient (SHGC) = 0.39
 U.S. ENERGY STAR Certified = Yes
 SKU = 238843
 Vendor Name = S/O SILVER LINE BLDG PRD
 Vendor Number = 60660514
 Customer Service = (888) 504-0005
 Catalog Version Date = 01/04/2021

End Line 1300 Description



Frame Width = 24
 Frame Height = 12

Line Number	Item Summary	Was Price	Now Price	Quantity	Total Savings	Total Price
1400-1	50 Series Buck Picture Window-2051 , Fixed , 24 x 12 , Beige / Beige	\$180.49	\$153.42	8	(\$216.56)	\$1,227.36
Unit 1400 Total:		\$180.49	\$153.42		(\$216.56)	\$1,227.36

Begin Line 1400 Description

---- Line 1400-1 ----

50 Series Buck Picture Window-2051
 Overall Rough Opening = 24 1/4" x 12 1/2"
 Overall Unit = 24" x 12"
 Installation Zip Code = 48206
 U.S. ENERGY STAR® Climate Zone = Northern
 ENERGY STAR Required = Yes
 Frame Width = 24
 Frame Height = 12
 Venting / Handing = Fixed
 Exterior Color = Beige
 Interior Finish Color = Beige

Performance Rating = PG35 / DP 50/50
 Glass Construction Type = Dual Pane
 Glass Option = Low-E2+ PS
 High Altitude Breather Tubes = No
 Glass Strength = Standard
 Glass Tint = No Tint
 Specialty Glass = None
 Gas Fill = Air
 None
 Vinyl Sill Angle = Sill Angle
 Head Expander = Yes

Room Location = Study room,
 Is this a Remake? = No
 Re-Order Item = No
 Unit U-Factor = 0.28
 Unit Solar Heat Gain Coefficient (SHGC) = 0.39
 U.S. ENERGY STAR Certified = Yes
 SKU = 238843
 Vendor Name = S/O SILVER LINE BLDG PRD
 Vendor Number = 60660514
 Customer Service = (888) 504-0005
 Catalog Version Date = 01/04/2021

End Line 1400 Description



Frame Width = 22 3/4
 Frame Height = 48 1/4

Line Number	Item Summary	Was Price	Now Price	Quantity	Total Savings	Total Price
1500-1	50 Series Buck Single-Hung-2001 Equal Sash , Fixed/Active , 22.75 x 48.25 , Beige / Beige	\$232.97	\$198.00	8	(\$279.76)	\$1,584.00
Unit 1500 Total:		\$232.97	\$198.00		(\$279.76)	\$1,584.00

Begin Line 1500 Description

---- Line 1500-1 ----

50 Series Buck Single-Hung-2001
 Overall Rough Opening = 23" x 48 3/4"
 Overall Unit = 22 3/4" x 48 1/4"
 Installation Zip Code = 48206
 U.S. ENERGY STAR® Climate Zone = Northern
 ENERGY STAR Required = Yes
 Frame Width = 22 3/4
 Frame Height = 48 1/4
 Venting / Handing = Fixed/Active
 Exterior Color = Beige
 Interior Finish Color = Beige
 Performance Rating = PG35 / DP 35/35
 Glass Construction Type = Dual Pane
 Glass Option = Low-E2+ PS

High Altitude Breather Tubes = No
 Glass Strength = Standard
 Glass Tint = No Tint
 Specialty Glass = None
 Gas Fill = Air
 Contour Grilles-Between-the-Glass
 Colonial
 Grille Pattern = Colonial
 Exterior Grille Color = Beige
 Interior Grille Color = Beige
 2W2H
 Number of Sash Locks = Single
 Lock Type = Standard
 Insect Screen Type = Half Screen

Insect Screen Material = Fiberglass
 Vinyl Sill Angle = Sill Angle
 Head Expander = Yes
 Room Location = Study,
 Is this a Remake? = No
 Re-Order Item = No
 Unit U-Factor = 0.28
 Unit Solar Heat Gain Coefficient (SHGC) = 0.34
 U.S. ENERGY STAR Certified = Yes
 SKU = 238843
 Vendor Name = S/O SILVER LINE BLDG PRD
 Vendor Number = 60660514
 Customer Service = (888) 504-0005
 Catalog Version Date = 01/04/2021

End Line 1500 Description

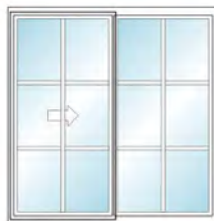

Frame Width = 47
 Frame Height = 48 1/4

Line Number	Item Summary	Was Price	Now Price	Quantity	Total Savings	Total Price
1600-1	50 Series Buck Single Gliding-2092 , Active/Stationary (XO) , 47 x 48.25 , Beige / Beige	\$257.38	\$218.75	4	(\$154.52)	\$875.00
Unit 1600 Total:		\$257.38	\$218.75		(\$154.52)	\$875.00

Begin Line 1600 Description

---- Line 1600-1 ----

50 Series Buck Single Gliding-2092
 Overall Rough Opening = 47 1/4" x 48 3/4"
 Overall Unit = 47" x 48 1/4"
 Installation Zip Code = 48206
 U.S. ENERGY STAR® Climate Zone = Northern
 ENERGY STAR Required = Yes
 Frame Width = 47
 Frame Height = 48 1/4
 Venting / Handing = Active/Stationary (XO)
 Exterior Color = Beige
 Interior Finish Color = Beige
 Performance Rating = PG15 / DP 15/15
 Glass Construction Type = Dual Pane
 Glass Option = Low-E PS Argon
 High Altitude Breather Tubes = No

Glass Strength = Standard
 Glass Tint = No Tint
 Specialty Glass = None
 Gas Fill = Argon
 Contour Grilles-Between-the-Glass
 Colonial
 Grille Pattern = Colonial
 Exterior Grille Color = Beige
 Interior Grille Color = Beige
 2W3H
 Hardware = Standard
 Hardware Color/Finish = Beige
 Number of Sash Locks = Double
 Lock Type = Standard
 Insect Screen Type = Half Screen

Insect Screen Material = Fiberglass
 Vinyl Sill Angle = Sill Angle
 Head Expander = Yes
 Room Location = Living and kitchen,
 Is this a Remake? = No
 Re-Order Item = No
 Unit U-Factor = 0.29
 Unit Solar Heat Gain Coefficient (SHGC) = 0.42
 U.S. ENERGY STAR Certified = Yes
 SKU = 238843
 Vendor Name = S/O SILVER LINE BLDG PRD
 Vendor Number = 60660514
 Customer Service = (888) 504-0005
 Catalog Version Date = 01/04/2021

End Line 1600 Description



Frame Width = 13
 Frame Height = 40 1/4

Line Number	Item Summary	Was Price	Now Price	Quantity	Total Savings	Total Price
1700-1	50 Series Buck Picture Window-2051 , Fixed , 13 x 40.25 , Beige / Beige	\$189.70	\$161.23	1	(\$28.47)	\$161.23

Begin Line 1700 Description

---- Line 1700-1 ----

50 Series Buck Picture Window-2051
 Overall Rough Opening = 13 1/4" x 40 3/4"
 Overall Unit = 13" x 40 1/4"
 Installation Zip Code = 48206
 U.S. ENERGY STAR® Climate Zone = Northern
 ENERGY STAR Required = Yes
 Frame Width = 13
 Frame Height = 40 1/4
 Venting / Handing = Fixed
 Exterior Color = Beige
 Interior Finish Color = Beige

Performance Rating = PG35 / DP 50/50
 Glass Construction Type = Dual Pane
 Glass Option = Low-E2+ PS
 High Altitude Breather Tubes = No
 Glass Strength = Standard
 Glass Tint = No Tint
 Specialty Glass = None
 Gas Fill = Air
 None
 Vinyl Sill Angle = Sill Angle
 Head Expander = Yes

Room Location = Entry closet,
 Is this a Remake? = No
 Re-Order Item = No
 Unit U-Factor = 0.28
 Unit Solar Heat Gain Coefficient (SHGC) = 0.39
 U.S. ENERGY STAR Certified = Yes
 SKU = 238843
 Vendor Name = S/O SILVER LINE BLDG PRD
 Vendor Number = 60660514
 Customer Service = (888) 504-0005
 Catalog Version Date = 01/04/2021

End Line 1700 Description



Frame Width = 17 3/4
 Frame Height = 58 1/4

Line Number	Item Summary	Was Price	Now Price	Quantity	Total Savings	Total Price
1800-1	50 Series Buck Picture Window-2051 , Fixed , 17.75 x 58.25 , Beige / Beige	\$270.17	\$229.64	2	(\$81.06)	\$459.28
Unit 1800 Total:		\$270.17	\$229.64		(\$81.06)	\$459.28

Begin Line 1800 Description

---- Line 1800-1 ----

50 Series Buck Picture Window-2051
 Overall Rough Opening = 18" x 58 3/4"
 Overall Unit = 17 3/4" x 58 1/4"
 Installation Zip Code = 48206
 U.S. ENERGY STAR® Climate Zone = Northern
 ENERGY STAR Required = Yes
 Frame Width = 17 3/4
 Frame Height = 58 1/4
 Venting / Handing = Fixed
 Exterior Color = Beige
 Interior Finish Color = Beige

Performance Rating = PG35 / DP 50/50
 Glass Construction Type = Dual Pane
 Glass Option = Low-E2+ PS
 High Altitude Breather Tubes = No
 Glass Strength = Standard
 Glass Tint = No Tint
 Specialty Glass = None
 Gas Fill = Air
 None
 Vinyl Sill Angle = Sill Angle
 Head Expander = Yes

Room Location = Dining closet,
 Is this a Remake? = No
 Re-Order Item = No
 Unit U-Factor = 0.28
 Unit Solar Heat Gain Coefficient (SHGC) = 0.39
 U.S. ENERGY STAR Certified = Yes
 SKU = 238843
 Vendor Name = S/O SILVER LINE BLDG PRD
 Vendor Number = 60660514
 Customer Service = (888) 504-0005
 Catalog Version Date = 01/04/2021

End Line 1800 Description



Frame Width = 22 3/4
 Frame Height = 48 1/4

Line Number	Item Summary	Was Price	Now Price	Quantity	Total Savings	Total Price
1900-1	50 Series Buck Single-Hung-2001 Equal Sash , Fixed/Active , 22.75 x 48.25 , Beige / Beige	\$232.97	\$198.00	1	(\$34.97)	\$198.00
Unit 1900 Total:		\$232.97	\$198.00		(\$34.97)	\$198.00

Begin Line 1900 Description

---- Line 1900-1 ----

50 Series Buck Single-Hung-2001
 Overall Rough Opening = 23" x 48 3/4"
 Overall Unit = 22 3/4" x 48 1/4"
 Installation Zip Code = 48206
 U.S. ENERGY STAR® Climate Zone = Northern
 ENERGY STAR Required = Yes
 Frame Width = 22 3/4
 Frame Height = 48 1/4
 Venting / Handing = Fixed/Active
 Exterior Color = Beige
 Interior Finish Color = Beige
 Performance Rating = PG35 / DP 35/35
 Glass Construction Type = Dual Pane
 Glass Option = Low-E2+ PS

High Altitude Breather Tubes = No
 Glass Strength = Standard
 Glass Tint = No Tint
 Specialty Glass = None
 Gas Fill = Air
 Contour Grilles-Between-the-Glass
 Colonial
 Grille Pattern = Colonial
 Exterior Grille Color = Beige
 Interior Grille Color = Beige
 2W2H
 Number of Sash Locks = Single
 Lock Type = Standard
 Insect Screen Type = Half Screen

Insect Screen Material = Fiberglass
 Vinyl Sill Angle = Sill Angle
 Head Expander = Yes
 Room Location = Dining room,
 Is this a Remake? = No
 Re-Order Item = No
 Unit U-Factor = 0.28
 Unit Solar Heat Gain Coefficient (SHGC) = 0.34
 U.S. ENERGY STAR Certified = Yes
 SKU = 238843
 Vendor Name = S/O SILVER LINE BLDG PRD
 Vendor Number = 60660514
 Customer Service = (888) 504-0005
 Catalog Version Date = 01/04/2021

End Line 1900 Description



Frame Width = 46 3/4
 Frame Height = 48 1/4

Line Number	Item Summary	Was Price	Now Price	Quantity	Total Savings	Total Price
2000-1	50 Series Buck Single Gliding-2092 , Active/Stationary (XO) , 46.75 x 48.25 , Beige / Beige	\$257.28	\$218.67	1	(\$38.61)	\$218.67
Unit 2000 Total:		\$257.28	\$218.67		(\$38.61)	\$218.67

Begin Line 2000 Description

---- Line 2000-1 ----

50 Series Buck Single Gliding-2092
 Overall Rough Opening = 47" x 48 3/4"
 Overall Unit = 46 3/4" x 48 1/4"
 Installation Zip Code = 48206
 U.S. ENERGY STAR® Climate Zone = Northern
 ENERGY STAR Required = Yes
 Frame Width = 46 3/4
 Frame Height = 48 1/4
 Venting / Handing = Active/Stationary (XO)
 Exterior Color = Beige
 Interior Finish Color = Beige
 Performance Rating = PG15 / DP 15/15
 Glass Construction Type = Dual Pane
 Glass Option = Low-E PS Argon
 High Altitude Breather Tubes = No

Glass Strength = Standard
 Glass Tint = No Tint
 Specialty Glass = None
 Gas Fill = Argon
 Contour Grilles-Between-the-Glass
 Colonial
 Grille Pattern = Colonial
 Exterior Grille Color = Beige
 Interior Grille Color = Beige
 2W3H
 Hardware = Standard
 Hardware Color/Finish = Beige
 Number of Sash Locks = Double
 Lock Type = Standard
 Insect Screen Type = Half Screen

Insect Screen Material = Fiberglass
 Vinyl Sill Angle = Sill Angle
 Head Expander = Yes
 Room Location = Dining room,
 Is this a Remake? = No
 Re-Order Item = No
 Unit U-Factor = 0.29
 Unit Solar Heat Gain Coefficient (SHGC) = 0.42
 U.S. ENERGY STAR Certified = Yes
 SKU = 238843
 Vendor Name = S/O SILVER LINE BLDG PRD
 Vendor Number = 60660514
 Customer Service = (888) 504-0005
 Catalog Version Date = 01/04/2021

End Line 2000 Description

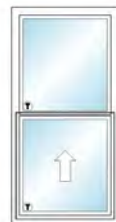

Frame Width = 24
 Frame Height = 48 1/2

Line Number	Item Summary	Was Price	Now Price	Quantity	Total Savings	Total Price
-------------	--------------	-----------	-----------	----------	---------------	-------------

2100-1	50 Series Buck Single-Hung-2001 Equal Sash , Fixed/Active , 24 x 48.5 , Beige / Beige	\$268.49	\$228.20	1	(\$40.29)	\$228.20
--------	--	----------	----------	---	-----------	----------

Unit 2100 Total:		\$268.49	\$228.20		(\$40.29)	\$228.20
-------------------------	--	-----------------	-----------------	--	------------------	-----------------

Begin Line 2100 Description

---- Line 2100-1 ----

<p>50 Series Buck Single-Hung-2001 Overall Rough Opening = 24 1/4" x 49" Overall Unit = 24" x 48 1/2" Installation Zip Code = 48206 U.S. ENERGY STAR® Climate Zone = Northern ENERGY STAR Required = Yes Frame Width = 24 Frame Height = 48 1/2 Venting / Handing = Fixed/Active Exterior Color = Beige Interior Finish Color = Beige Performance Rating = PG35 / DP 35/35 Glass Construction Type = Dual Pane</p>	<p>Glass Option = Low-E2+ PS High Altitude Breather Tubes = No Glass Strength = Tempered Glass Tint = No Tint Specialty Glass = None Gas Fill = Air None Number of Sash Locks = Single Lock Type = Standard Insect Screen Type = Half Screen Insect Screen Material = Fiberglass Vinyl Sill Angle = Sill Angle</p>	<p>Head Expander = Yes Room Location = 1/2 Bath, Is this a Remake? = No Re-Order Item = No Unit U-Factor = 0.29 Unit Solar Heat Gain Coefficient (SHGC) = 0.37 U.S. ENERGY STAR Certified = Yes SKU = 238843 Vendor Name = S/O SILVER LINE BLDG PRD Vendor Number = 60660514 Customer Service = (888) 504-0005 Catalog Version Date = 01/04/2021</p>
--	--	--

End Line 2100 Description

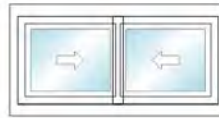

Frame Width = 33
Frame Height = 17

Line Number	Item Summary	Was Price	Now Price	Quantity	Total Savings	Total Price
2200-1	70 Series Buck Double Gliding-8700 , Active-Passive , 33 x 17 , Beige / Beige	\$212.52	\$180.63	2	(\$63.78)	\$361.26
Unit 2200 Total:		\$212.52	\$180.63		(\$63.78)	\$361.26

Begin Line 2200 Description

---- Line 2200-1 ----

<p>70 Series Buck Double Gliding-8700 Overall Rough Opening = 33 1/4" x 17 3/4" Overall Unit = 33" x 17" Installation Zip Code = 48206 U.S. ENERGY STAR® Climate Zone = Northern ENERGY STAR Required = Yes Frame Width = 33 Frame Height = 17 Venting / Handing = Active-Passive Exterior Color = Beige Interior Finish Color = Beige Performance Rating = PG40 Glass Construction Type = Dual Pane</p>	<p>Glass Option = Low-E PS Argon High Altitude Breather Tubes = No Glass Strength = Standard Glass Tint = No Tint Specialty Glass = None Gas Fill = Argon None Hardware Color/Finish = Beige Number of Sash Locks = Single Lock Type = Standard Insect Screen Type = Half Screen Insect Screen Material = Fiberglass Foam = Foam in Frame</p>	<p>Vinyl Sill Angle = Sill Angle Head Expander = Yes Room Location = Basement, Is this a Remake? = No Re-Order Item = No Unit U-Factor = 0.3 Unit Solar Heat Gain Coefficient (SHGC) = 0.44 U.S. ENERGY STAR Certified = Yes SKU = 253304 Vendor Name = S/O SILVER LINE BLDG PRD Vendor Number = 60660514 Customer Service = (888) 504-0005 Catalog Version Date = 01/04/2021</p>
--	---	---

End Line 2200 Description



Limited Lifetime Warranty

Residential Vinyl Windows and Patio Doors

Subject to the terms and conditions stated herein, American Craftsman™ window and/or patio door products (including mechanical parts, components and insulated glass), are warranted to be free from the following defects in manufacturing, materials and workmanship to the Original Purchaser for the lifetime of the product:

- a) Blistering, peeling, flaking, rotting or corrosion.
- b) Material obstruction of vision on the internal surfaces of the insulated glass unit caused by seal failure of the insulated glass unit.

In the event a failure occurs as a result of a defect in manufacturing, materials or workmanship within the limited warranty period, American Craftsman, upon receipt of the original part/component/material or validation of the complaint, will at its option: 1) provide a new replacement part/component/material; or 2) provide a factory-authorized repair to the existing part/component/material; or 3) refund the purchase price or the retailer's/dealer's price at the time of the original purchase, whichever is less. American Craftsman reserves the right to require return of the defective part(s)/component(s)/material(s).

Patio Doors with Shades/Blinds in Insulated Glass

Subject to the terms and conditions stated herein, the shades/blinds in insulated glass (including insulated glass, shade/blind insulated glass seal and external control mechanisms attached to the glass) in American Craftsman™ patio doors are warranted to be free from defects in manufacturing, materials and workmanship to the Original Purchaser for ten (10) years from the date of purchase from the dealer.

In the event a failure occurs as a result of a defect in manufacturing, materials or workmanship within the limited warranty period, American Craftsman, upon receipt of the original part/component/material or validation of the complaint, will at its option: 1) provide a new replacement part/component/material; or 2) provide a factory-authorized repair to the existing part/component/material; or 3) refund the purchase price or the retailer's/dealer's price at the time of the original purchase, whichever is less. American Craftsman reserves the right to require return of the defective part(s)/component(s)/material(s).

Residential Vinyl Windows and Patio Doors in Commercial Applications

American Craftsman™ windows and doors installed in a building operated as a multi-family dwelling or used for commercial purposes or rental properties such as schools, houses of worship, apartment complexes, government-owned structures, office buildings, etc., are warranted to be free from defects in manufacturing, materials and workmanship to the Original Purchaser for ten (10) years from the date of purchase from the dealer. In the event a failure occurs as a result of a defect in manufacturing, materials or workmanship within the limited warranty period, American Craftsman, upon receipt of the original part/component/material or validation of the complaint, will at its option: 1) provide a new replacement part/component/material; or 2) provide a factory-authorized repair to the existing part/component/material; or 3) refund the purchase price or the retailer's/dealer's price at the time of the original purchase, whichever is less. American Craftsman reserves the right to require return of the defective part(s)/component(s)/material(s).

Limited Warranty for Exterior Color Finish

The color finish on the exterior components (frame, sash, panels, sills and grilles) on American Craftsman vinyl residential window and/or patio door products is warranted to the Original Purchaser to be free from manufacturing defects resulting in color fade greater than 5 delta E* (when measured in accordance with ASTM 2244) and free from blistering, cracking, peeling and any loss of adhesion for a period of ten (10) years from the date of purchase from the retailer/dealer.

What is not covered by this exterior color finish warranty: exterior colors of white, soft white, beige and sandtone; accessories and hardware, including insect screen frames and aluminum coil stock.

In the event there is a defect covered by this limited warranty for exterior color finish within the limited warranty period, American Craftsman, at its option, will: 1) refinish the product - labor is included (the finish will be applied with standard commercial refinishing techniques and may not be the same finish as originally applied to the product); 2) repair the product; 3) provide replacement part(s) or product(s) to the American Craftsman retailer/dealer you specify - labor is not included; or 4) refund the purchase price or the retailer's/dealer's price at the time of the original purchase, whichever is less.

*Technical measurement of color fade

What is NOT Covered by This Limited Warranty

- Product failure or damage due to the following:
 - The improper installation of the product.
 - The improper application or use of the product.
- The occurrence of accidents, vandalism, fire, floods, acts of God including, but not limited to, earthquakes and hurricanes.
- Any modification or alteration to the product.
- The failure to perform reasonable and necessary maintenance on the product.
- The neglect, abuse, improper handling and/or improper storage of the product.
- Exposure of the product to excessive heat and/or cold beyond naturally occurring conditions.
- Stresses caused by building defects or settlement or movement of the structure in which the product is installed.

- The application of harmful cleaning solutions or products including, but not limited to, acetone, petroleum products or abrasive compounds.
- Misalignment of grilles/muntins of 1/8" or less from appropriate position.
- Slight fading and/or color variations caused by normal aging or weathering.
- Torn or ripped insect screens for any cause whatsoever.
- The improper removal of any permanent warning or identification labels from the product or products.
- The rusting or corrosion of non-vinyl products or components due to the close proximity to coastal areas unless the product is composed of appropriate stainless steel or other non-corrosive hardware.
- Installation of the product or products outside of the 48 contiguous United States.

Additional Items Excluded From This Limited Warranty

- Minor blemishes in the glass that do not significantly impair the structure or vision through the glass, including glass curvature.
- Color variation or variations of the glass.
- Glass breakage for any cause or any reason.
- Damage due to exposure to stresses arising from glass surface temperature differentials or caused by building settlement or movement.
- Condensation on the external surfaces of the window and/or glass, which may occur as the natural result of humidity and interior/external temperature differentials.
- Damage due to the transportation or installation of the glass product or products at altitudes in excess of 3,500 feet above or below point of manufacture unless equipped with capillary or breather tubes.
- The very gradual, natural migration of inert gas used in insulated glass units.
- Improper application, alteration, modification, or use of the insulated glass units, including the application of aftermarket films.

For quality assurance purposes, all window and patio door products should be inspected by the Original Purchaser prior to, at the time of installation, or upon transfer of title to the Original Occupant.

General Conditions and Exclusions

The limited warranty set forth in this document is the only express warranty (either written or oral) applicable to American Craftsman™ windows and doors, and no one is authorized to modify or expand this limited warranty. All warranty claims must be made during the applicable warranty period.

ALL IMPLIED WARRANTIES INCLUDING MERCHANTABILITY AND FITNESS FOR A PARTICULAR PURPOSE ARE LIMITED TO THE APPLICABLE STATUTE OF LIMITATION, BUT IN NO CASE WILL EXTEND BEYOND THE TERM OF THE LIMITED WARRANTIES SET FORTH ABOVE. AMERICAN CRAFTSMAN EXCLUDES AND WILL NOT PAY FOR INCIDENTAL OR CONSEQUENTIAL DAMAGES, WHETHER ARISING OUT OF CONTRACT, TORT OR OTHERWISE, AND ITS LIABILITY WILL IN ALL INSTANCES BE LIMITED TO THE REPAIR OR REPLACEMENT OR REFUND OF THE ACTUAL PURCHASE PRICE OF THE DEFECTIVE PRODUCT.

Some states do not allow limitations on how long an implied warranty lasts and/or the exclusion or limitation of incidental or consequential damages, so the above limitations may not apply to you. These warranties give you specific legal rights and you may also have other rights which vary from state to state.

The warranties cover replacement parts, components and/or materials only, and American Craftsman does not assume any expense or responsibility involved with the removal and/or reinstallation of any replacement parts, components or materials. American Craftsman reserves the right to discontinue the model or models manufactured under these warranties. Any discontinued parts, components or materials may be replaced with an equivalent part at the sole discretion of American Craftsman. American Craftsman is not responsible for any color variation in the replacement part, component or material. American Craftsman is not responsible for any window or door which has been modified in any manner to accommodate an alarm system which may be attached to the product nor is it responsible for the reconnecting of the window or door to the alarm system. American Craftsman reserves the right to inspect any and all products with alleged defects in the field. Field visits may result in service charges for non-warranty inspections.

ELIGIBILITY REQUIREMENTS

Enforceability of the warranties set forth above is limited to the Original Purchaser. The term "Original Purchaser" as used in this limited warranty means:

- That individual, individuals or entity who or which took original title to the premises or are the original occupants of the structure in which the product was installed.

Claim Procedure

To make a claim under this Limited Warranty, contact us at:

American Craftsman Window and Door Company
Attn: Warranty Department
P.O. Box 6029
North Brunswick, New Jersey 08902-6029

You may also contact us on our web site at www.americancraftsmanwindows.com or reach us by phone at 888-504-0005.

You can help us serve you faster by providing the following important information:

- Description of the product such as the exterior color, unit type and size and inside visible glass measurements.
- Product information from the product label.
- Description of product concerns.
- Documentation of the purchase date, if available.
- Original purchaser's name, address (with zip code) where the product is installed and telephone numbers.

NON-TRANSFERABILITY: The warranties described above are non-transferable and limited to the Original Purchaser as described above.

If any part of the warranties described above is void or unenforceable in any State of the United States, the remaining portions will nonetheless continue in full force and effect.

W2500™ & W3500™ Window Line Review

Awnings, Casements, Double-Hung & Patio Doors



Meeting Needs – Retail Market

New Construction, Remodeling, or Replacement
Full Offering / The Differences are the Standards & Options

- W2500™
 - W3500™
 - W4500™
- } 20 Year Limited Warranty

■ W2500™ High Quality Standard Line

Most Popular Designs, Options & Standard Sizes

- Double-Hung
 - Natural & Primed
 - Clad Unit / W2500
- Casement & Awning
 - Clad Only
- Patio Doors / Sliding & Swing

■ W3500™

More Options, Heaver Look & Custom Sizes

- W2500™ Frame / Heavier Traditional Sash
- Clad Units
- Double-Hung, Casements, & Awnings

W2500™



W3500™



Complete Standard Offering

High Performance Designs

- Clad Casement
- Clad Awning
- Double Hung
 - Clad
 - Natural & Primed
- Pictures & Transoms
- Fixed Geometric Shapes
- Sliding Patio Doors
- Swinging Patio Doors

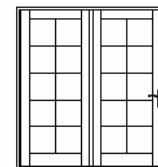
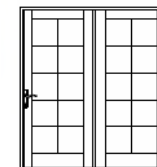
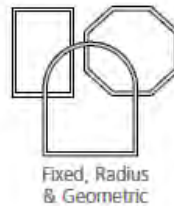

High Performance Cladding

- Aluminum Cladding Stops at Glazing
 - Improved Energy Efficiency
- Engineered Sill - Aluminum / PVC
 - Extruded Aluminum Skin
 - PVC Chambered Interior Construction
 - Improved Energy Efficiency
 - Added Strength
- ENERGY STAR® Available
- Extruded Frame & Roll Form Sash

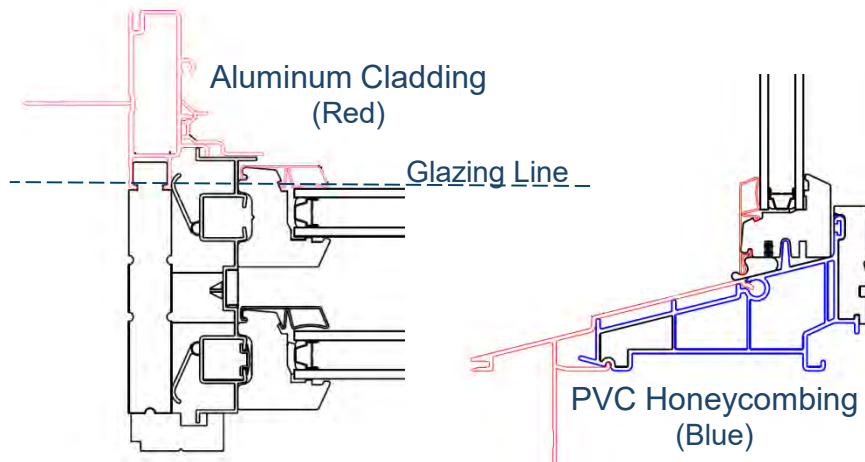

Frame

- AuraLast Pine
- Jambs 4-9/16", 6-9/16" and 7-9/16"
- Jamb Liner – Compression
- Front View / Hidden Jamb Liner
- Screen Frames Match Cladding Color

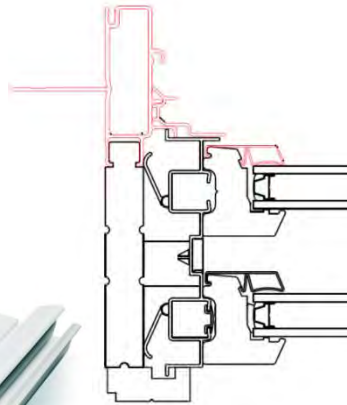
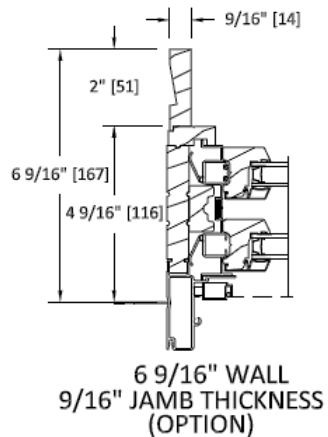

W2500 Clad Double-Hung

Sash

- Pine
- Glass Area Maximized
 - Sizes
 - Stiles - 1 1/4"
 - Top & Bottom Rails - 1 1/4"

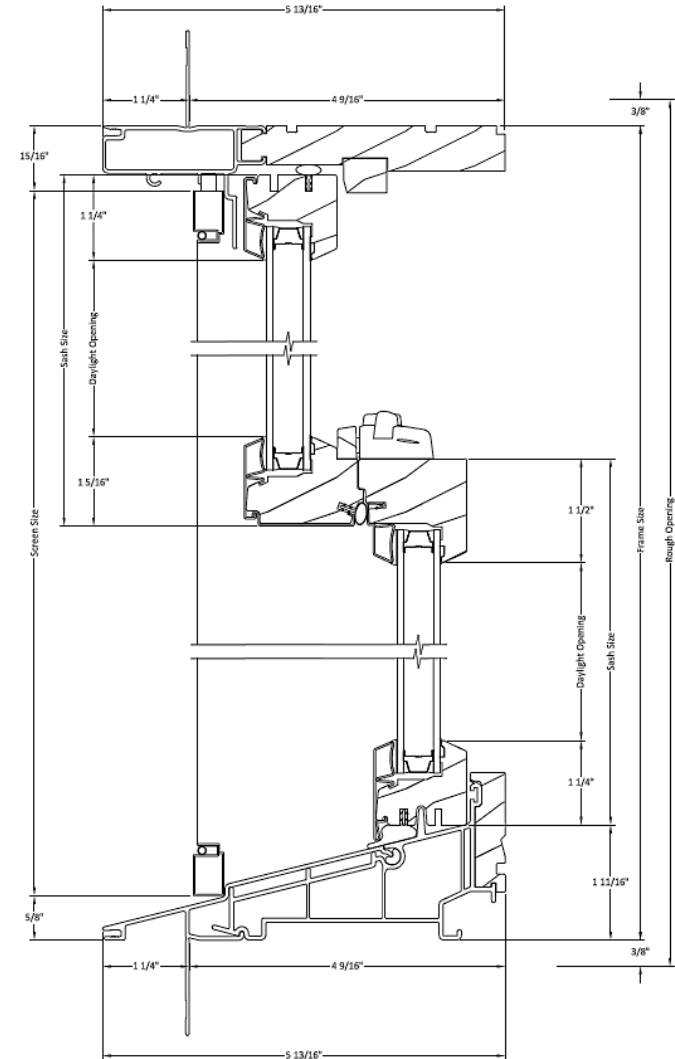
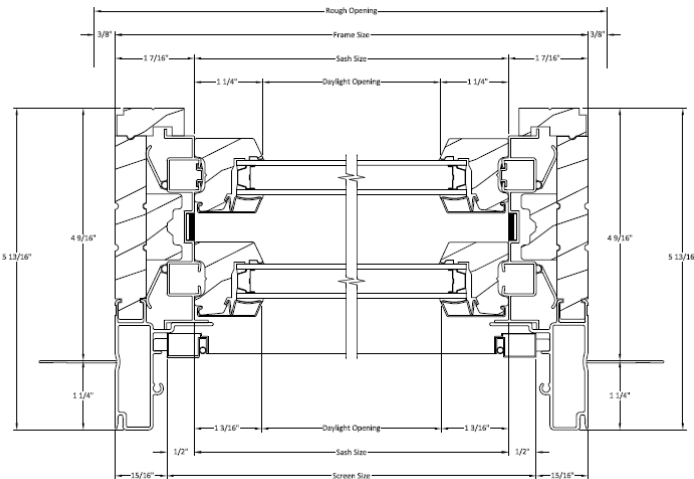

Sizes

Standard

- 6 Widths
- 9 Heights
- 7 Exterior Clad Colors

Nominal

- 5 Nominal Widths
- 7 Nominal Heights
- 5 Exterior Clad Colors

Standard Sizes

<u>Widths</u>	<u>Heights</u>
21 ⅜	36
25 ⅜	40
29 ⅜	48
33 ⅜	52
37 ⅜	56
41 ⅜	60
	64
	72
	76

Nominal Sizes

<u>Widths</u>	<u>Heights</u>
19 ¼	35 ¼
23 ¼	41 ¼
27 ¼	47 ¼
31 ¼	53 ¼
35 ¼	59 ¼
	65 ¼
	71 ¼

Standard Size Clad Colors (7)



Nominal Size Clad Colors (5)

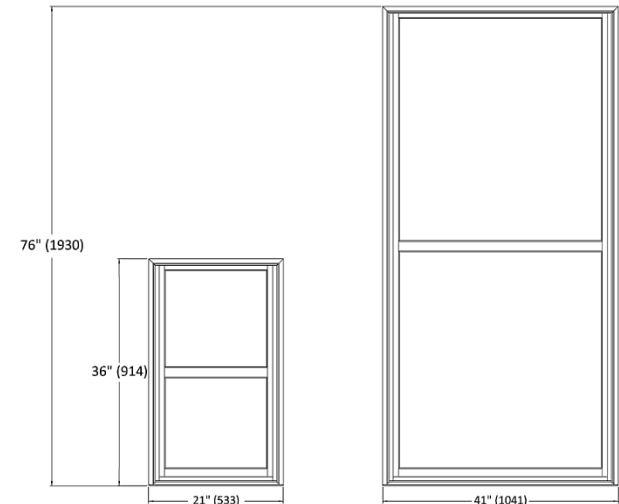

Multiple Assemblies

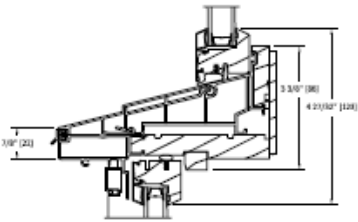

OPERATING DOUBLE HUNG
WITH IN SASH
PICTURE/TRANSOM

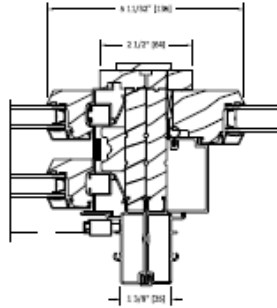

OPERATING DOUBLE HUNG
BESIDE IN-SASH
PICTURE/TRANSOM

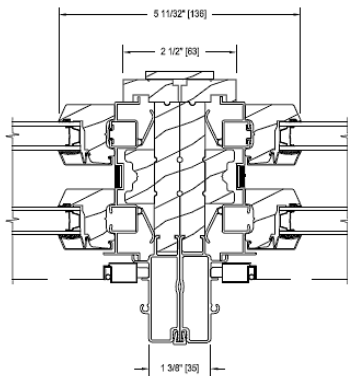

TWIN OPERATING DOUBLE HUNG

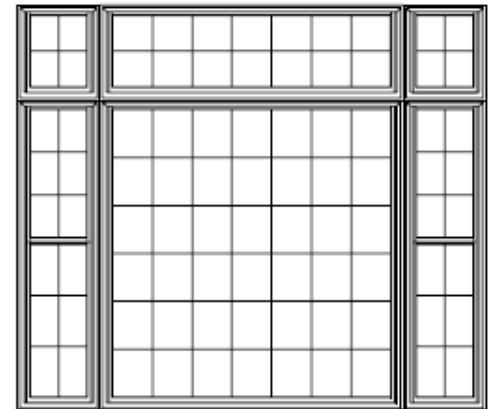
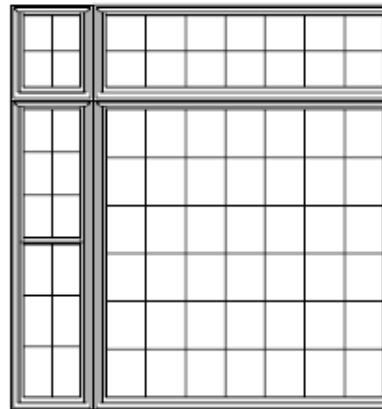
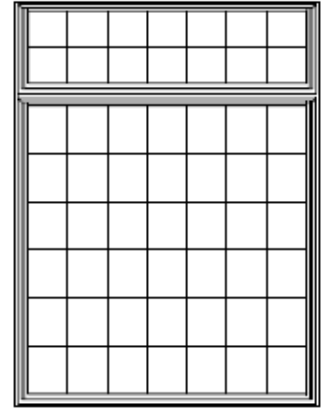
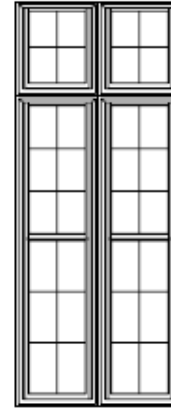
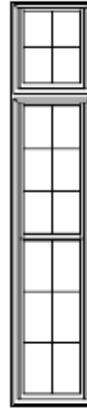

Wood Double Hung

Note: Tradition Plus Unit

- AuraLast Pine
- AuraLast Primed Pine
- Jambs 4-9/16", 6-9/16" and 7-9/16"
- Jamb Liner - Compression
- Unit Sizes / Standard & Custom
 - Width: 21³/₈ to 45³/₈
 - Height: 36¹/₂ to 92¹/₂

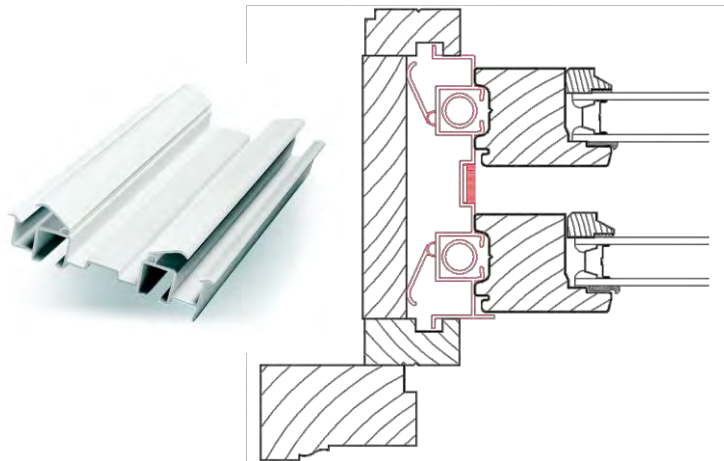

Wood Double Hung

- Sash
 - Stiles - 1 3/4"
 - Top & Bottom Rails - 2 9/16"

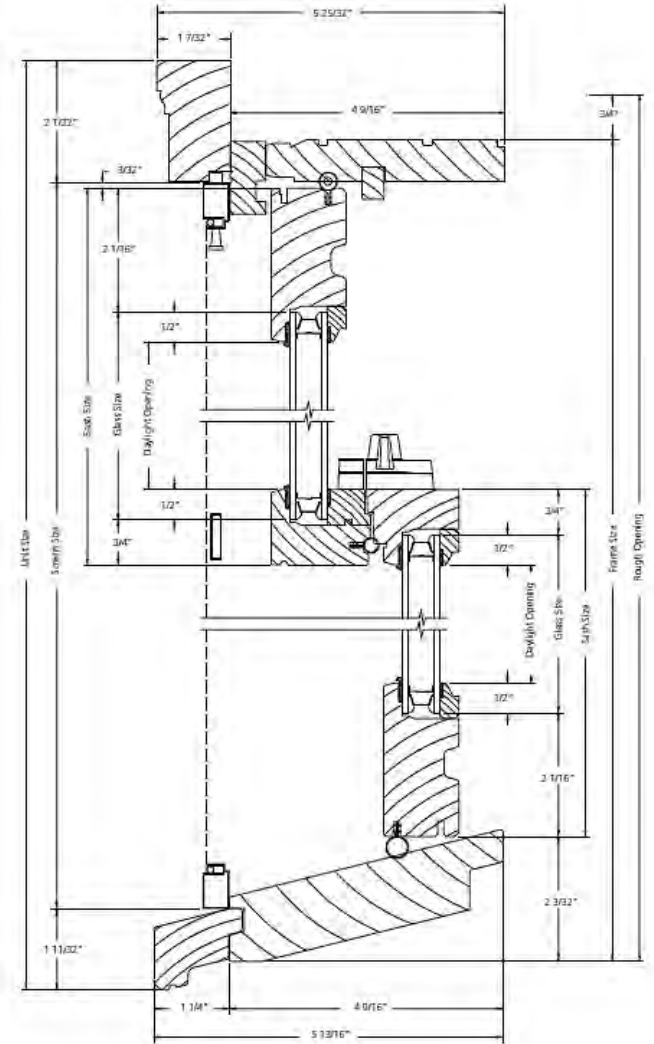
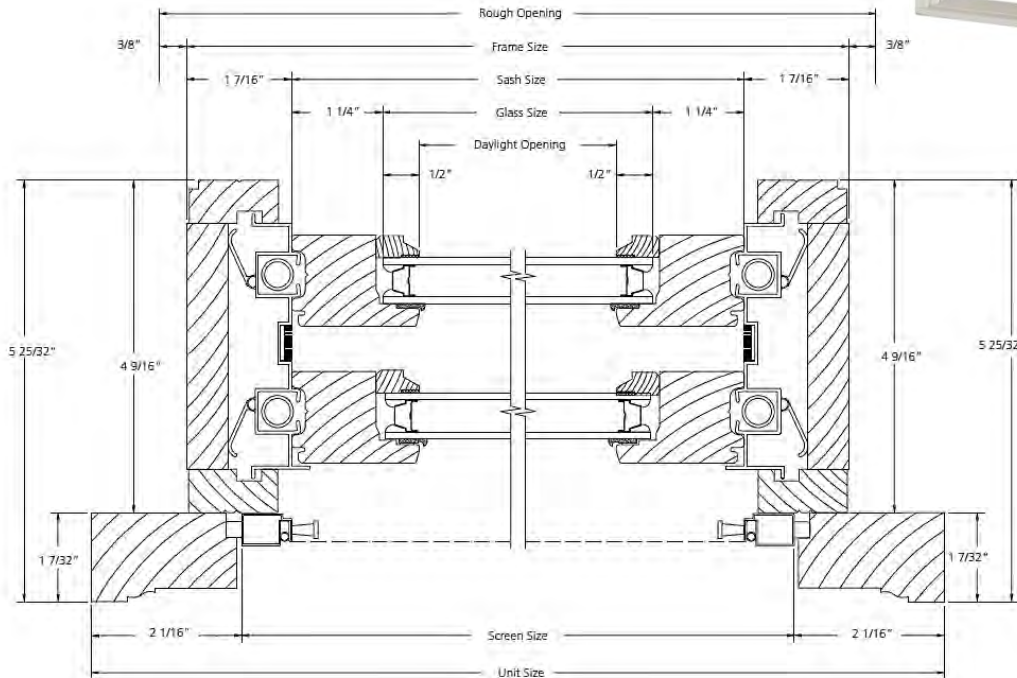

Interiors

- Pine Interior
- Compression Jamb Liner
 - Sash Tilt Out
 - Sash Removable
- Secure Stylized Cam Lock
 - 7 Hardware Finishes
 - Provides Solid Weather-strip Contact

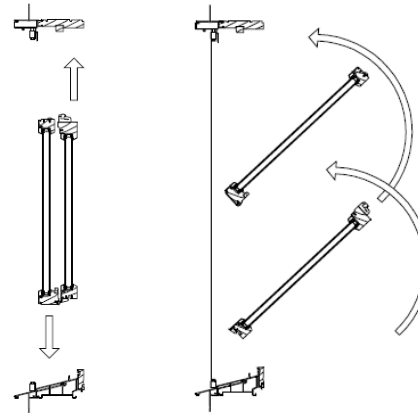

Compression Jamb Liner

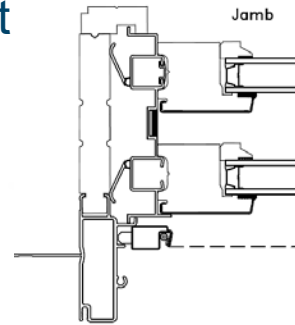

Pine Interior



**Cam Lock
7 Hardware Finishes**

Painted Finishes



White Desert Sand Chestnut Bronze

Plated Finishes



Polished Brass Oil-Rubbed Bronze Brushed Chrome Antique Brass



Exterior Standard Specifications

- Aluminum Clad Units Only
 - Frame: Extruded Aluminum Clad / W2500
 - Sash: Roll Form Aluminum Clad
 - Sill: Engineered - Aluminum / PVC Honeycomb
 - Aluminum Skin
 - PVC Chambered Interior Construction
 - Improved Energy Efficiency
 - Added Strength
 - ENERGY STAR® Available
- AuraLast® Wood
- Standard & Custom Sizes
 - Width: 21 3/8 to 41 3/8
 - Height : 36 to 76
- Jambs 4-9/16"



PVC
Honeycomb



Exterior Standard Specifications

- Sash
 - Stiles - 1 3/4"
 - Rails - 2 9/16"
- Optional Cottage Units
- Multiple Assemblies

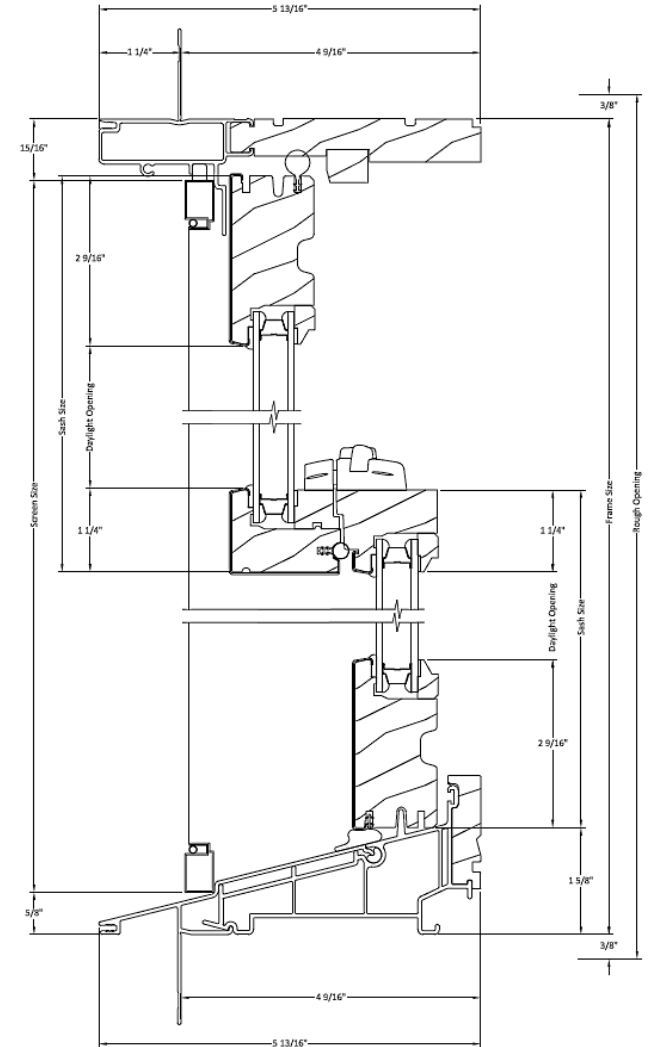
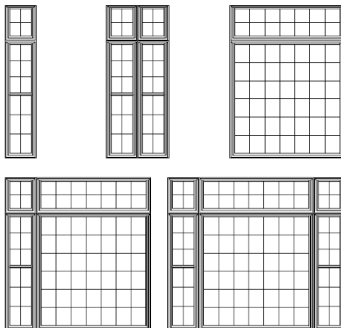
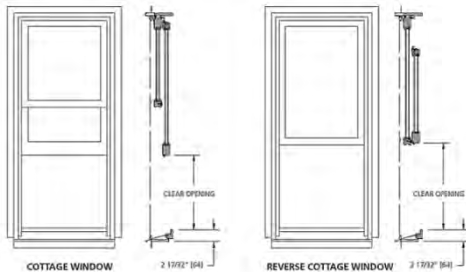

W-3500™ Double Hung Interior

- Pine Interior
- Compression Jamb Liner
 - Sash Tilt Out
 - Sash Removable
- Secure Stylized Cam Lock
 - Provides Solid Weather-strip contact
 - 7 Hardware Finishes

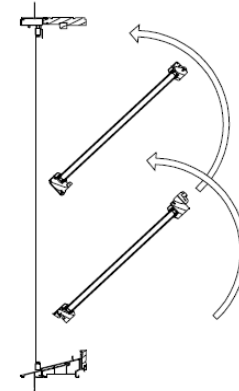

Cam Lock
7 Hardware Finishes

Painted Finishes



Plated Finishes



Pine Interior

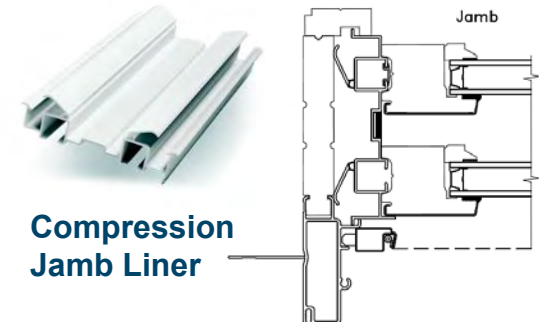

Compression Jamb Liner