

**STAFF REPORT:** 10-14-2020 MEETING

**PREPARED BY:** A. DYE

**APPLICATION NUMBER:** 20-6883

**ADDRESS:** 1041 CLARK

**HISTORIC DISTRICT:** HUBBARD FARMS

**APPLICANT:** LOGESH RAJENDRAN, DMC CONSULTANTS; CITY OF DETROIT BRIDGING NEIGHBORHOODS PROGRAM

**PROPERTY OWNER:** RUDY GARCIA

**DATE OF PROVISIONALLY COMPLETE APPLICATION:** 9/24/2020

**DATE OF STAFF SITE VISIT:** 10/02/2020

**SCOPE:** REPLACE EXISTING WOOD WINDOWS WITH NEW WOOD WINDOWS

**EXISTING CONDITIONS**

The 2-1/2 story Queen Anne structure at 1041 Clark was built in 1915. Although constructed two years later than the neighboring house at 1035 Clark, it has an almost identical design. Sited high on the property, steps lead from the sidewalk to a raised entry porch constructed of rusticated concrete block which is currently painted gray. Aluminum siding covers the entire house and its installation covered the window casings and brick mould. A two-story bay window culminating with a large gable dominates the front elevation. A pediment on the covered front entry and a hip roofed dormer above, along with a steeply pitched roof, creates a strongly angled front facade.

Wood framed windows are present within most of the existing window openings. The applicant states all of the existing windows have wood sash, however staff can't substantiate this due to some interior photos having closed blinds as well as the graininess of the interior photo of the rear elevation sliding window. A leaded glass transom remains in situ on the front/east elevation.

A very small single story rear addition, which extends past the adjacent rear entrance porch, was constructed sometime after 1950. A single story deck, which looks to be a composite material, extends from the rear door into the yard.



Above photo: HDC staff, October 2, 2020.

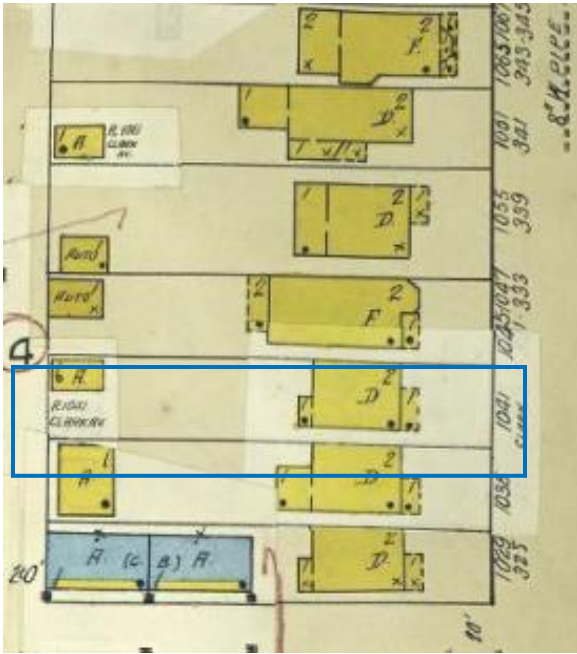

Sanborn Map Company, Vol. 1, 1921 - Oct 1950, Sec. 102

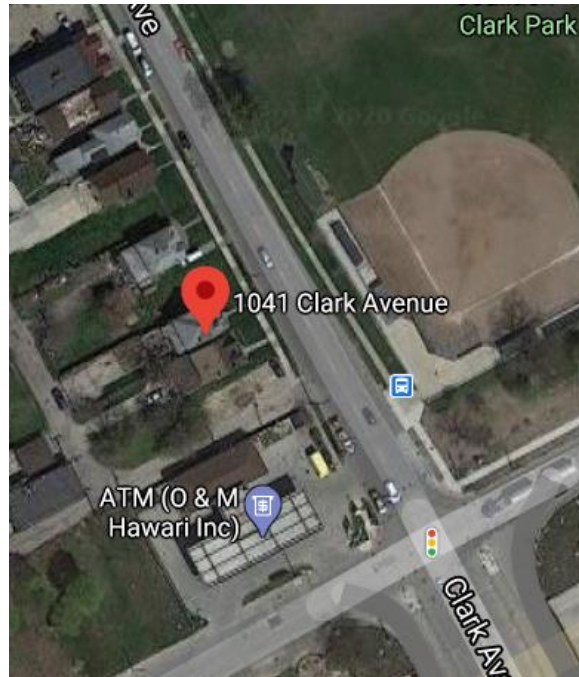

The house is located within the Bridging Neighborhoods Program. Per the City of Detroit's website: *The Bridging Neighborhoods I-75 Environmental Mitigation Program offers home mitigations to address noise and air quality impacts from increased truck traffic related to the Gordie Howe International Bridge Project. Eligible homes may receive some or all of the following mitigations: updated windows, updated HVAC systems, air filters, and insulation.*

- Must live in either the **YELLOW** or **GREEN** zone on the map AND
- Must own a property that is within 300 feet of the planned I-75 Service Drive AND
- Must not have been acquired by the Michigan Department of Transportation to facilitate construction of the bridge

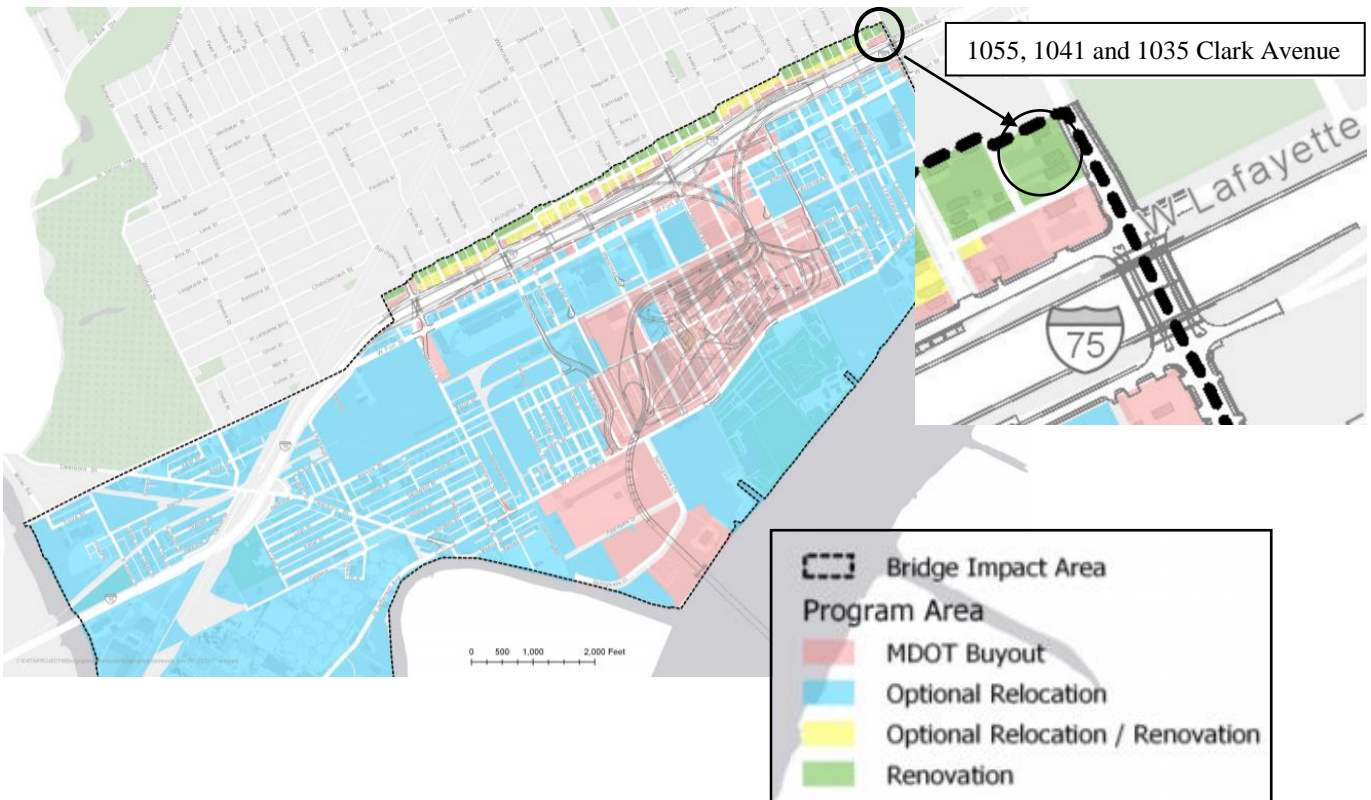

## PROPOSAL

The applicant proposes to remove all of the existing windows within the house and install replacement windows as allowed by the Bridging Neighborhoods 1-75 Mitigation Program. Specifically, the applicant is seeking the Commission's approval to remove all existing window sash and window jambs and replace with new wood, aluminum-clad window sash as per the submitted window quote. The applicant confirmed with HDC staff the existing casings, inner stop, and brick mould will be retained/will remain in their current condition.

The dominant window style is double-hung, with one-over-one wood sash. Two exceptions to this condition include:

- A first floor, front elevation, center bay window, which is a large fixed window and leaded glass transom above.
- A first floor, rear elevation, sliding window.

According to the applicant's window replacement order, the leaded glass transom would be replaced with a clear glass transom that would be factory mulled to the new fixed window. A new sliding window is proposed to replace the existing sliding window.

## STAFF OBSERVATIONS AND RESEARCH

- The Hubbard Farms Historic District was established in 1992.
- It is staff's opinion the aluminum siding was likely in place at the time of local historic district designation as vinyl siding didn't surpass aluminum siding in popularity until the 1980s-1990s.
- It is staff's understanding the aluminum siding installation caused the wood brick mould to be covered in order to keep water away from the house. If the brick mould had been left exposed, water would run down the wood, travel behind the siding, and become trapped between the siding and the house.
- Much of the aluminum siding in the north elevation gable is missing.
- There is no record in DPI of HDC review/COA being issued for the rear deck. *Please note: This is not part of the current application.*

## ISSUES

- At the time of the staff report, photographs of the windows on the northside elevation (exterior and interior) were missing from the application.
- The applicant has not identified the exterior aluminum-cladding color.
- The applicant proposes to install Weather Shield Windows, Weather Shield series. These are wood-framed units with exterior aluminum cladding. The comparison of the existing wood frames against the Weather Shield window frames is below.

<u>Existing Frames</u>		<u>Proposed Frames</u>		<u>Percentage Increase</u>
Width of frame	2"	Width of frame	3-3/16"	62%
Depth of frame	1-3/8"	Depth of frame	4-9/16"	200%
Height of meeting rail	1-3/8"	Height of meeting rail	2-7/8"	100%
Depth of meeting rail	1-3/8"	Depth of meeting rail	3-3/16"	133%

- The window order proposes to replace ALL of the windows in the house; the leaded glass transom will be removed and replaced with a clear glass transom.
- The window replacement includes not just the operable sash but also the window jambs. The applicant confirmed with HDC staff the casings, inner stop, and brick mould will be retained and the windows will remain covered with aluminum trim.
- The Weather Shield, wood aluminum-clad windows have substantially thicker window frames. The dimensional increase is too large, and the loss of the leaded glass transom is not compatible with the scale and architectural features of the existing windows and house. Therefore, it is staff's opinion the proposed windows do not meet the Secretary of the Interior Standards.

## RECOMMENDATION

Staff recommends the Commission consider issuing a NOTICE TO PROCEED for the window replacement at 1041 Clark Avenue. As this property falls within the service area of the Bridging Neighborhoods I-75 Environmental Mitigation Program, the Notice to Proceed may fall under the following Condition:

*2) The resource is a deterrent to a major improvement program that will be of substantial benefit to the community. Substantial benefit shall be found only if the applicant proposing the work has obtained all necessary planning and zoning approvals, financing, and environmental clearances, and the improvement program is otherwise feasible;*

If a Notice to Proceed is issued, staff recommends the Commission include the following conditions:

- The existing windows will remain in place until the replacement windows are approved by Commission staff.
- The new window frame dimensions shall not increase more than ¼-inch (from the existing frame dimensions).
- The operation and glass within each new window unit will match the existing window.
- The leaded glass transom window will remain in place and be repaired as needed.
- Existing wood mullions, if present, will remain in place. New, single window units will be inserted into existing window openings.
- The new windows will be solid wood (exterior to be painted) **or** solid wood, aluminum-clad units. The exterior frame color will be submitted for review.
- The existing exterior wood brick mould will be retained and will remain covered with aluminum.

If any of the above conditions not be met, HDC staff will require the applicant to submit a revised proposal for the Commission's review at an upcoming meeting.



1035 Clark is on the left; 1041 Clark is on the right.  
HDC Staff photo, October 2, 2020



HDC Staff Photo, October 2, 2020



HDC Staff Photo, October 2, 2020



Applicant Photo, date unknown.

THIS IS A 3-PAGE FORM - ALL INFORMATION IS REQUIRED FOR PROJECT REVIEW

# HISTORIC DISTRICT COMMISSION PROJECT REVIEW REQUEST

City of Detroit - Planning & Development Department  
2 Woodward Avenue, Suite 808  
Detroit, Michigan 48226

Date: 8/20/2020

## PROPERTY INFORMATION

ADDRESS: 1041 Clark Street AKA: \_\_\_\_\_

HISTORIC DISTRICT: Hubbard Farms

SCOPE OF WORK: (Check ALL that apply)

<input checked="" type="checkbox"/> Windows/ Doors	<input type="checkbox"/> Roof/Gutters/ Chimney	<input type="checkbox"/> Porch/ Deck	<input type="checkbox"/> Landscape/Fence/ Tree/Park	<input type="checkbox"/> General Rehab
<input type="checkbox"/> New Construction	<input type="checkbox"/> Demolition	<input type="checkbox"/> Addition	<input type="checkbox"/> Other: _____	

## APPLICANT IDENTIFICATION

Property Owner/  
Homeowner  Contractor  Tenant or  
Business Occupant  Architect/Engineer/  
Consultant

NAME: Logesh Rajendran COMPANY NAME: DMC Consultants, Inc

ADDRESS: 13500 Foley CITY: Detroit STATE: MI ZIP: 48209

PHONE: 3134911815 MOBILE: \_\_\_\_\_ EMAIL: Logeshr@dmccconsultantsusa.com

## PROJECT REVIEW REQUEST CHECKLIST

Please attach the following documentation to your request:

**\*PLEASE KEEP FILE SIZE OF ENTIRE SUBMISSION UNDER 30MB\***

**Completed Building Permit Application** (highlighted portions only)

**ePLANS Permit Number** (only applicable if you've already applied for permits through ePLANS)

**Photographs** of ALL sides of existing building or site

**Detailed photographs** of location of proposed work (photographs to show existing condition(s), design, color, & material)

**Description of existing conditions** (including materials and design)

**Description of project** (if replacing any existing material(s), include an explanation as to why replacement--rather than repair--of existing and/or construction of new is required)

**Detailed scope of work** (formatted as bulleted list)

**Brochure/cut sheets** for proposed replacement material(s) and/or product(s), as applicable

### NOTE:

Based on the scope of work, additional documentation may be required.

See [www.detroitmi.gov/hdc](http://www.detroitmi.gov/hdc) for scope-specific requirements.

Upon receipt of this documentation, staff will review and inform you of the next steps toward obtaining your building permit from the Buildings, Safety Engineering and Environmental Department (BSEED) to perform the work.

**SUBMIT COMPLETED REQUESTS TO [HDC@DETROITMI.GOV](mailto:HDC@DETROITMI.GOV)**



# 1041 Clark

City of Detroit

Bridging Neighborhoods

I-75 Environmental Mitigation Program



# Description of Project

The Bridging Neighborhoods Program was created by City Council Resolution and approved by the Mayor on July 26, 2017.

The home for which this application was created falls within the service area of the I-75 Environmental Mitigation Program which, per Exhibit A Item H. of the resolution is required to provide a “retrofit package designed to protect occupants of the Retrofit-Eligible Home from air pollution and noise pollution.... Retrofit packages may include new windows; air filters; insulation; and/or heating, ventilation, and air conditioning systems.”

Because of the requirement to provide new windows, we seek permission to replace the existing windows.

# Scope of Work

- Replacing existing wood windows with new STC 27 wood windows. Interior casings and stops will be retained. Exterior brick mold is covered with white aluminum trim outside (refer to the pictures attached). Existing living room window stained glass **A10** is damaged (refer to the picture) and needs to be repaired.

# Description of Existing Conditions

The property at 1041 Clark street has existing single pane, double hung wood windows.

As you review the provided images, you will see that these windows are in various states of repair.

The windows all have exterior white paint.

NOT TO SCALE

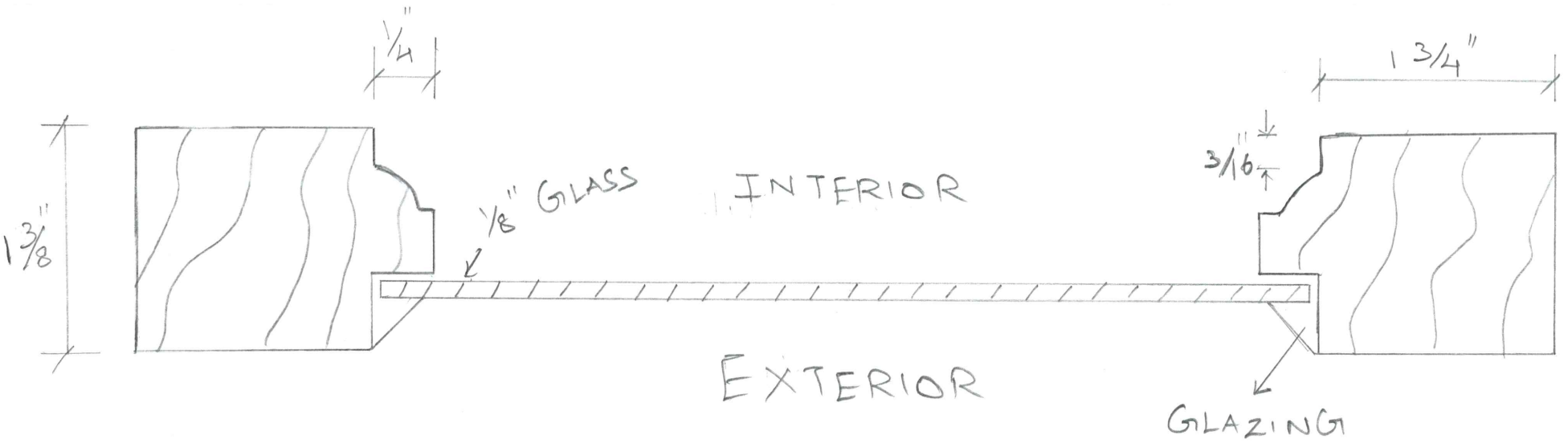

EXISTING SASH DETAILS

1035 CLARK and 1041 CLARK

NOT TO SCALE

EXISTING MEETING RAIL

1035 CLARK AND

1041 CLARK

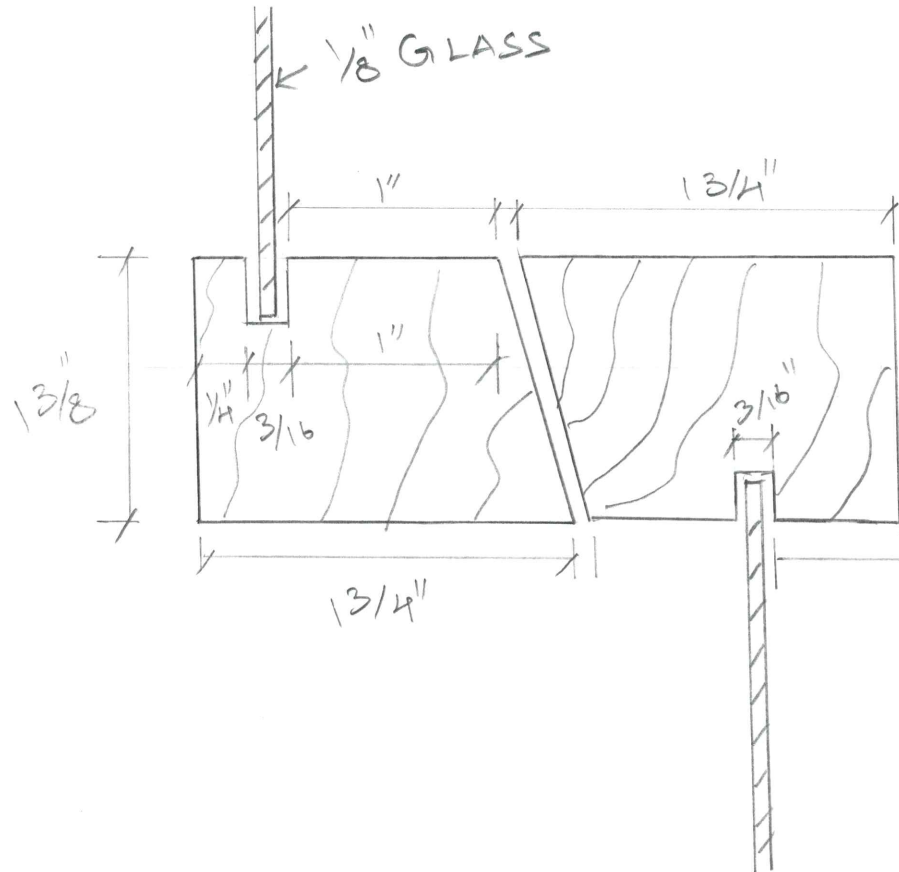

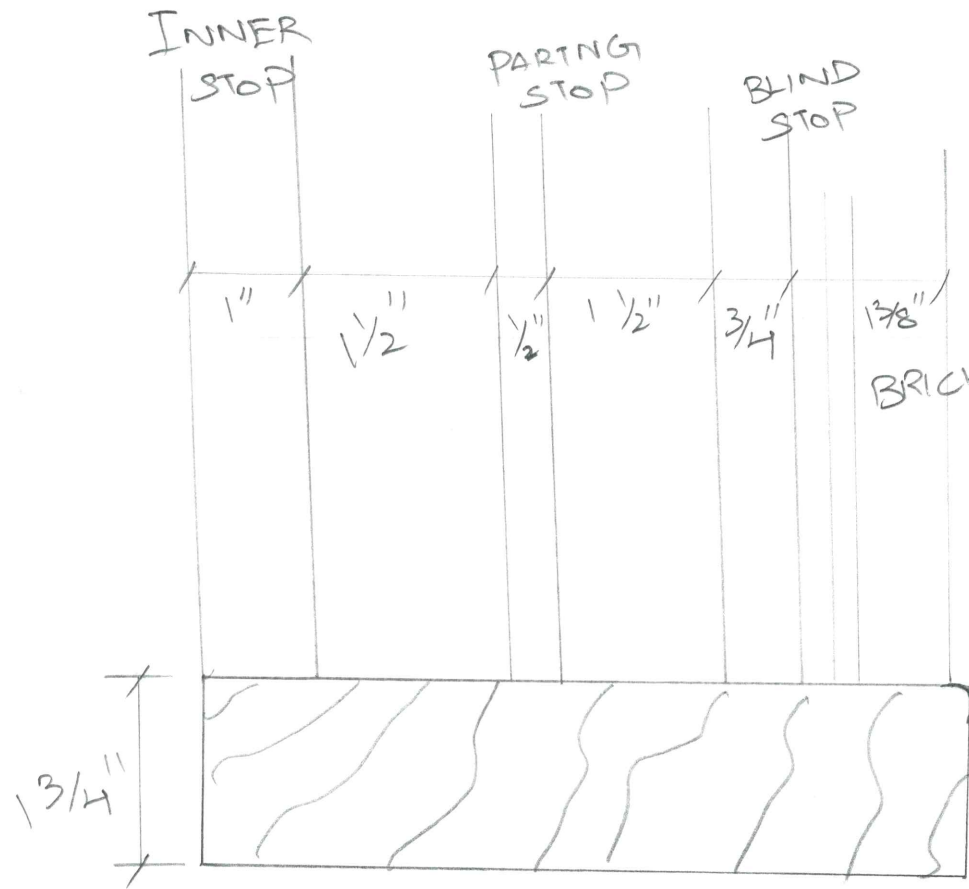

BRICK MOLD WRAPPED WITH ALUMINUM TRIM COIL

EXISTING SILL AND JAMB

1041 CLARK

EXISTING BRICK MOLD - COVERED WITH ALUMINUM TRIM

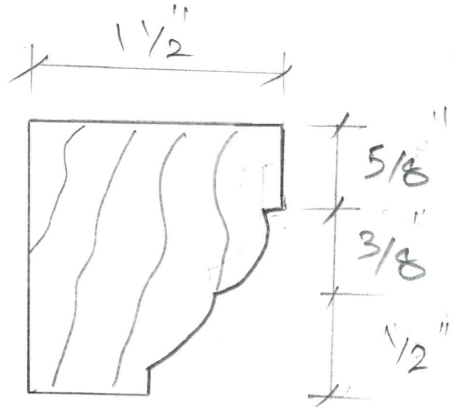



# Brochure/Cut Sheet

- -

# Weather Shield®

## Weather Shield Series™

# Double Hung Windows

## CROSS SECTION DETAILS

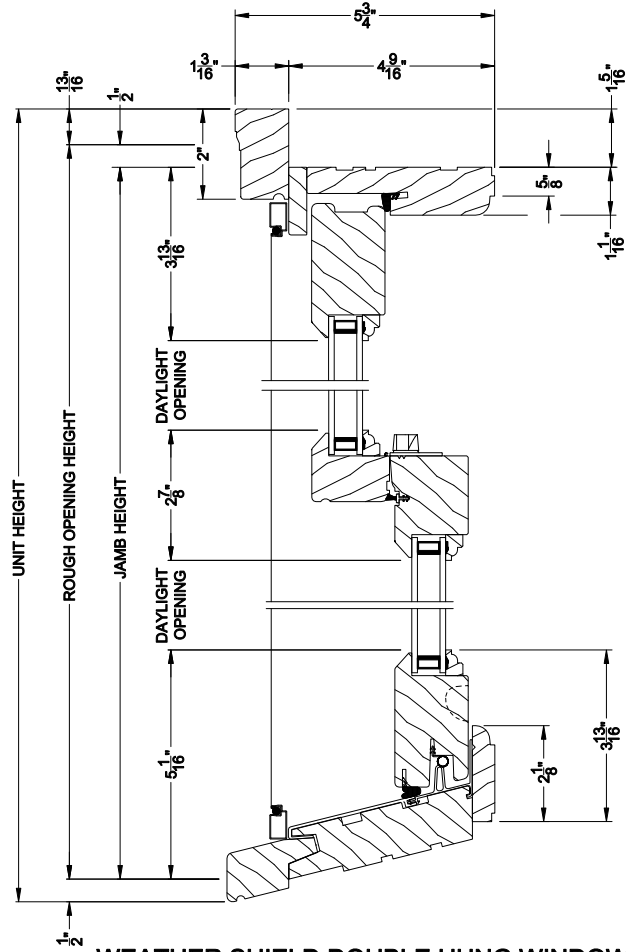

**WEATHER SHIELD DOUBLE HUNG WINDOW (610)**  
Vertical Section

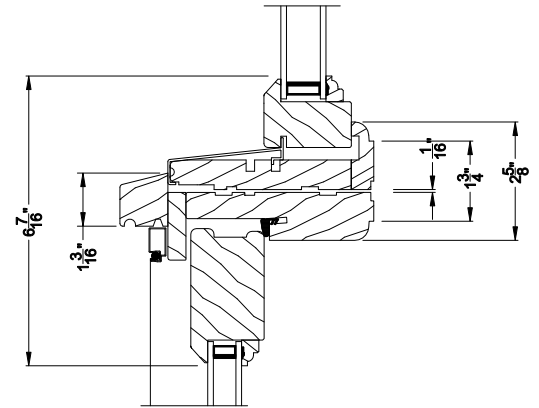

**WEATHER SHIELD DOUBLE HUNG WINDOW**  
Horizontal Stack Section - Transom Stack over DH

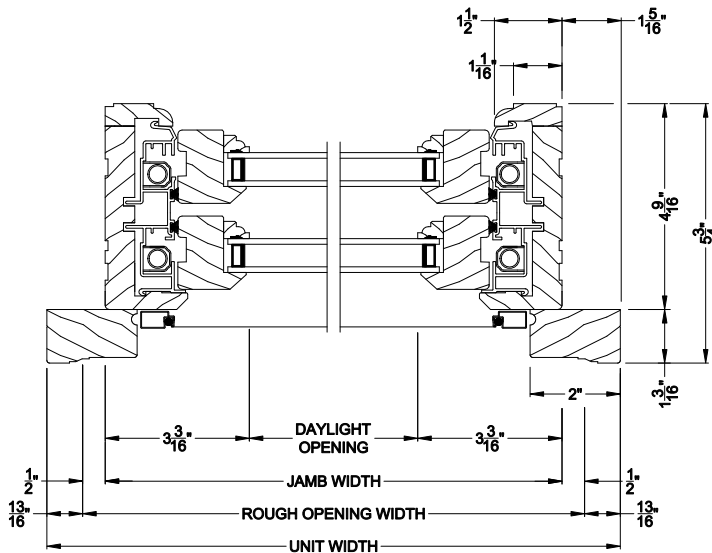

**WEATHER SHIELD DOUBLE HUNG WINDOW (610)**  
Horizontal Section

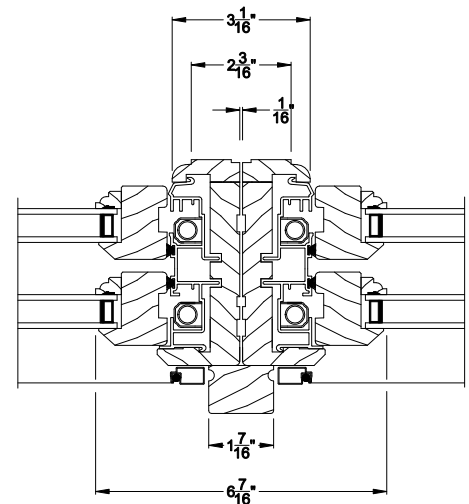

**WEATHER SHIELD DOUBLE HUNG WINDOW**  
Vertical Mull Section - DH / DH

Note: All dimensions are approximate. Weather Shield reserves the right to change specifications without notice.

# Weather Shield®

## Weather Shield Series™

# Double Hung Windows

## CROSS SECTION DETAILS

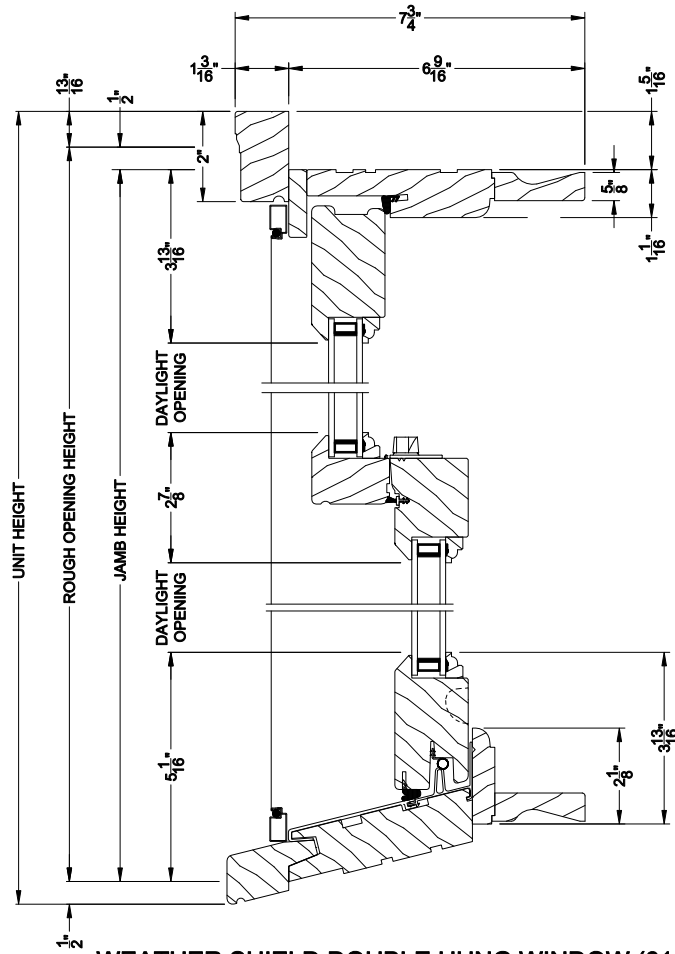

**WEATHER SHIELD DOUBLE HUNG WINDOW (610)**  
Vertical Section - 6-9/16" jamb

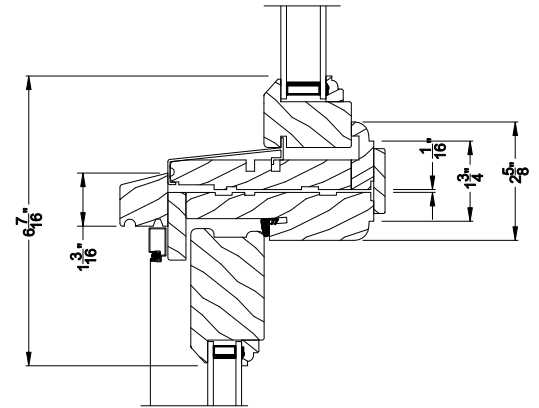

**WEATHER SHIELD DOUBLE HUNG WINDOW**  
Horizontal Stack Section - Transom Stack over DH

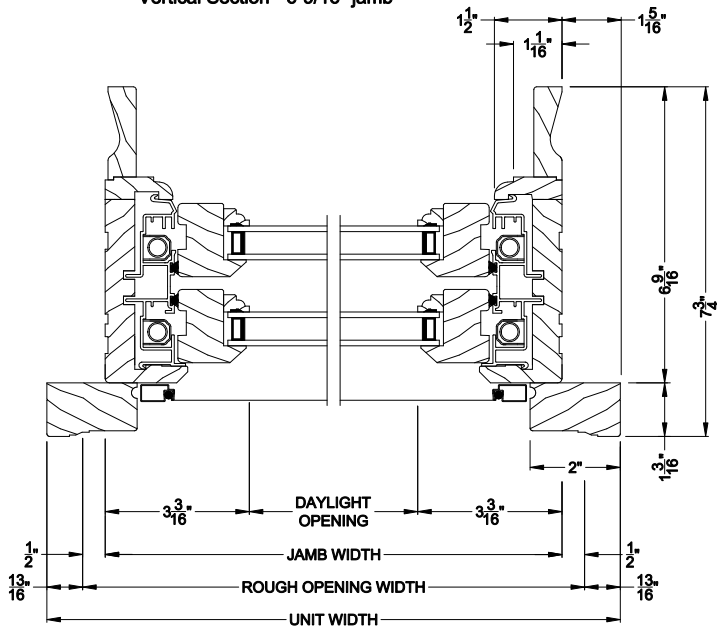

**WEATHER SHIELD DOUBLE HUNG WINDOW (610)**  
Horizontal Section - 6-9/16" jamb

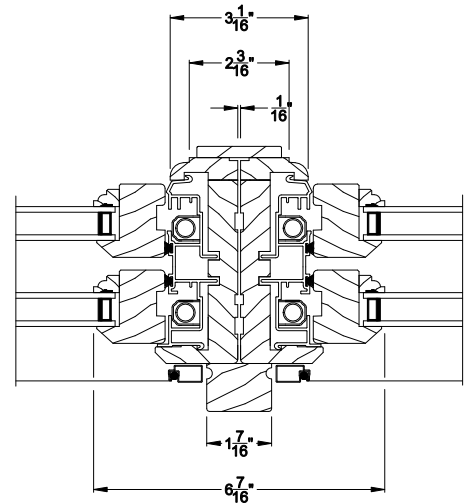

**WEATHER SHIELD DOUBLE HUNG WINDOW**  
Vertical Mull Section - DH / DH

Note: All dimensions are approximate. Weather Shield reserves the right to change specifications without notice.



## EXTERIOR COLOR OPTIONS

To help you get the exact look you desire, we offer an ever-expanding palette of durable and distinct exterior color options rated to the highest industry standards (AAMA 2605) for color retention. Our Premium windows and doors are available in 12 standard and 45 designer colors, 8 anodized and 4 radiant metallic colors, with unlimited custom color match aluminum finishes.

### Standard Exterior Colors (AAMA 2605 premium paint)



### Radiant Metallic Colors (AAMA 2605 premium paint)



## Designer Exterior Colors (AAMA 2605 premium paint)



## Anodized Exterior Aluminum Finishes

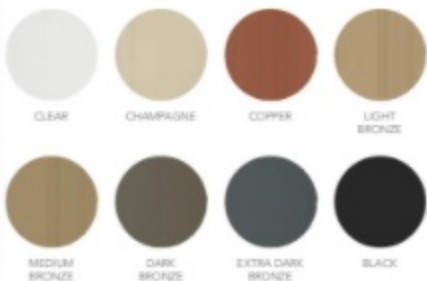

## Textured Exterior Aluminum Finishes



Finishes and colors shown may not be actual representations. Please visit an authorized Weather Shield dealer for color samples.

## INTERIOR OPTIONS



## INTERIOR WOOD OPTIONS

Every home is different. So we give you choices to add your own special touch. Choose the wood grain and color that complement your design. Then add warmth and beauty with our factory finishes. Whether subtle or stunning, you'll find options to make a lasting impression.

### Rich Wood Interiors

With eight wood species to choose from, there's sure to be one perfect for your home. For a truly unique look, other wood species are available upon request.



### FACTORY FINISHES ON PINE

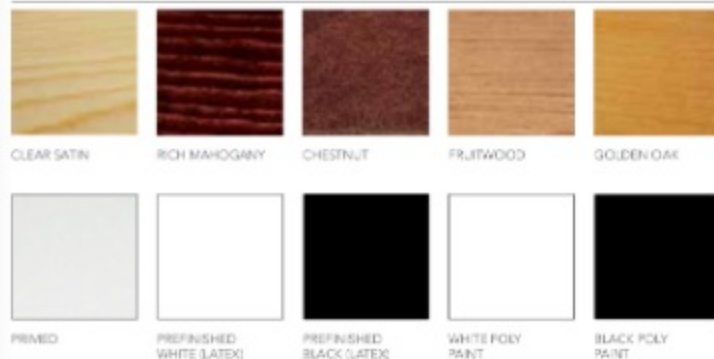

### Durable Factory Finishes

Save time and money with our factory finishing. The wood is stained and sealed on all surfaces to help repel moisture and includes two Clear Satin top coats for durability and easy cleaning.

### DESIGNER STAINS ON PINE

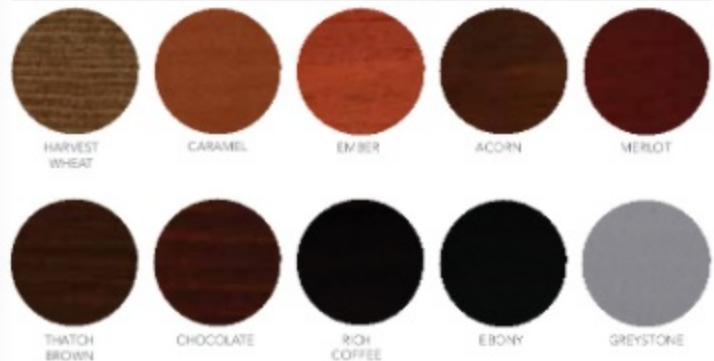

### Designer Stains

Explore our new furniture-grade stain offering created in partnership with leading paint and coatings manufacturer Sherwin-Williams®. These new stains provide clean, vivid colors with high pigmentation for excellent clarity and uniformity.

**PROUDLY FINISHED WITH  
SHERWIN-WILLIAMS.**

### 7 Step Process

Our intensive seven step process creates a long-lasting premium finish that will protect and enhance the beauty of your windows and doors for years to come.

### 7 STEPS TO CREATE A FURNITURE GRADE STAIN

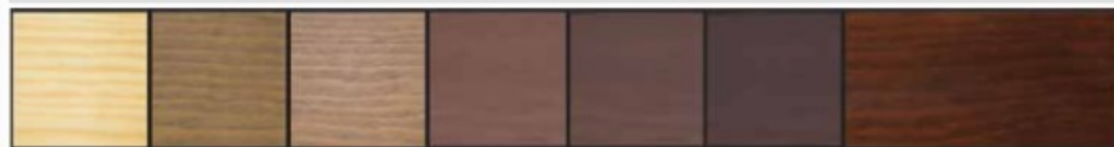

- FINE SANDING**  
Prepares wood to accept coatings.
- WASH COAT**  
A toned wood conditioner that fills wood pores and creates an even finish.
- STAIN COAT**  
Primary color coat, designed to highlight the natural beauty of the wood.
- SEALER COAT**  
Builds a smooth surface that locks down the color and provides chemical and moisture resistance.
- BUFFING**  
Surfaces are buffed to create an ultra-smooth surface.
- TONER COAT**  
This step is used to even out the color and add depth and richness to the final look.
- CLEAR COAT COMPLETED FINISH**  
A specially formulated 2K Polyurethane topcoat designed to protect from UV and scratching.

Finishes and colors shown may not be actual representations. Please visit an authorized Weather Shield dealer for color samples. All finishes not available on all wood species. Please visit an authorized Weather Shield dealer for details.

## ARCHITECTURALLY INSPIRED, TECHNOLOGICALLY ADVANCED

Our double hung windows represent a one-of-a-kind approach to a popular choice in home design. With the versatility to open from the top or bottom, a breath of fresh air is never out of reach. From robust ventilation to energy efficiency and ease of use, double hung windows are a timeless classic.



**Natural Finish**  
A wood jambliner covers all mechanical balance systems to create a tailored aesthetic.



**Tilt and Release**  
With concealed tilt release latches, nothing comes between you and the view. Recessed into the lock rail, this design element leaves the sash clear of all visible latch hardware.



**Single Handed Ease**  
The single dual action lock allows the sash to be unlocked and tilted easily with one hand – so you can save your energy for the things that really matter.



### High Quality Exteriors

Our aluminum exterior-clad wood products feature commercial-grade premium AAMA 2605 paint that resists fading and chalking. Extruded aluminum resists dents, dings and scratches and is backed by Weather Shield's 20-year limited warranty.

The 3-1/2" bottom rail creates clean lines and ideal architectural proportions.

### The Beauty is in the Details

The rigid integral nailing fin makes installation simple and provides more durability than flimsy snap-in or fold-out fins found with other windows.

Butt jointed cadding accurately mimics traditional wood windows for a familiar aesthetic.

## DOUBLE HUNG WINDOWS



### WINDOWS SHOWN:

Configuration: Double Hung  
Interior Finish: White Poly  
Features: 5/8" Simulated Divided Lite  
Glass: Insulated Low-E with Argon

## GRILLE OPTIONS

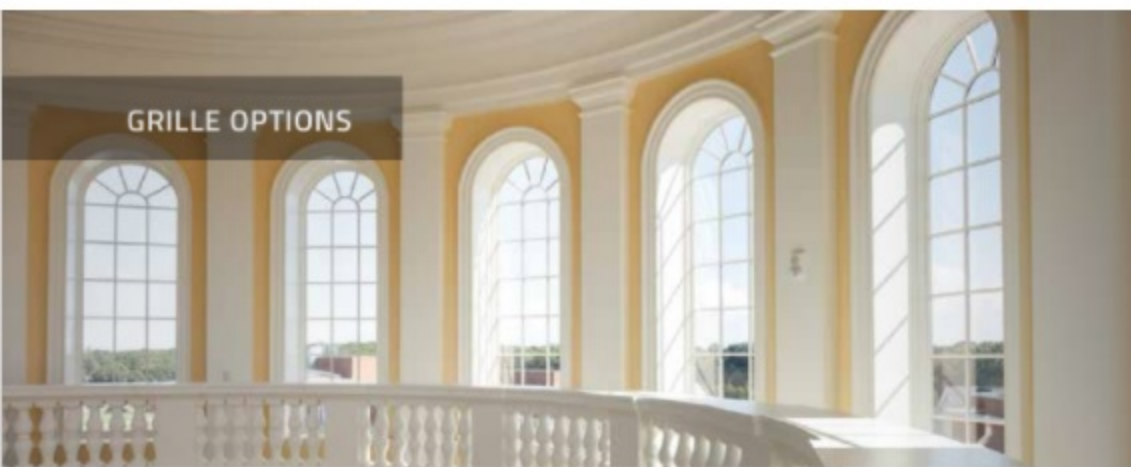

## OUTSTANDING PERFORMANCE, EXCEPTIONAL EFFICIENCY

Selecting the right windows is crucial in determining the style and elegance of your home. We offer only top-of-the-line design and construction, so you can choose among the industry's most innovative options. State-of-the-art windows like these are an investment that pays for itself in a lifetime of reduced costs.

### The Perfect Grille

Personalize your home with windows featuring a selection of bar widths and profiles, as well as traditional grille patterns and custom designs. For even greater **creativity and design** flexibility, most grilles can be manufactured from Weather Shield's custom wood interiors collection.

### Custom Grille Pattern Options

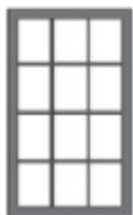

RECTANGULAR



FRAME



FRAME W/ VERTICAL BAR



COTTAGE



COTTAGE T



OREL



SINGLE HORIZONTAL BAR



SIMULATED DOUBLE HUNG

### Putty Exterior Aluminum Profile

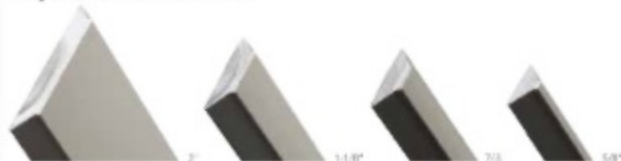

### Colonial Interior Wood Profile

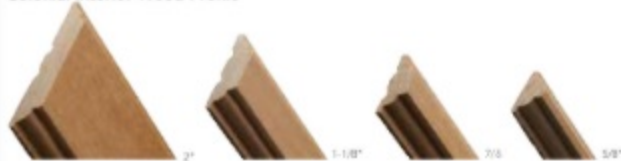

### Putty Interior Wood Profile



### Square Interior Wood Profile

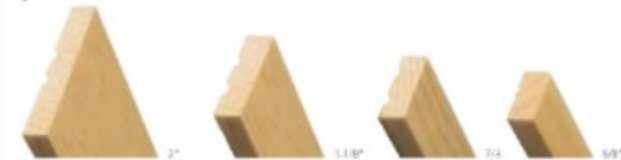

### Framed With You in Mind

Featuring a unique **perimeter grille frame design** that rests on the inside of the unit, Weather Shield windows employ a concealed pin system to snap the perimeter grille frame securely into place. These grilles can be easily removed in order to clean the entire interior glass surface.



7/8"



### Innovative Design; Classic Appeal

The best of modern energy efficiency meets old-world charm in **Simulated Divided Lite (SDL)** grilles. While mimicking the look of classic single-pane windows, SDL grilles offer exterior and interior grille bars either with or without an aluminum spacer bar — translating to powerful insulation and innovation.

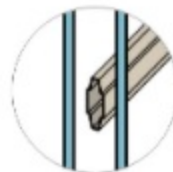

### Grilles Between the Glass

**Airspace Grilles** seal aluminum grille bars in either a sculptured or flat design between two panes of glass. Resulting in a classic aesthetic that is easy to clean and maintain.



1 1/16" SCULPTURED



5/8" FLAT



## GLASS OPTIONS



## REFLECTIONS OF QUALITY

From specialty glass to high-end glazing, our windows are truly a cut above the rest. Add color and texture options to the glass in your home while enjoying the energy efficiency and quality for which we're known best.

### Gold Standard

Weather Shield Premium Series products are certified and labeled according to the highest standards, set by the Window and Door Manufacturers Association (WDMA)/National Fenestration Ratings Council (NFRC) Certification Program. All WDMA/NFRC certified products must pass performance tests conducted by an independent lab for resistance to air leakage, water penetration and wind pressures.

### Specialty Glass Options

Add color or texture — or privacy and modesty — to your palette of design options. Special finishes and tint can give a project distinction. Specialty glass includes bronze, gray, rain and obscure.



BRONZE GRAY RAIN GLASS OBSCURE GLASS SAFIN ETOH

### High Quality Glaze

Maximize your windows' energy efficiency with the exclusive Zo-e-shield® glazing system. With powerful layers of Low-E coating, optional EasyCare® surface coating, inert gas-filled insulating airspace, and Real Warm-Edge™ spacers, our glazing options represent the ultimate in energy efficiency for any climate.

### Glazing Options



#### Insulated Low-E

##### All Climate

- Minimizes the sun's heat and damaging UV rays in warmer months
- Reflects the sun's heat back into room during cooler months



#### Zo-e-shield 5

##### Ultimate Solar Control

- Strong resistance to the sun's glaring heat
- Excellent insulating value
- Excellent protection against damaging UV rays
- Maintains great clarity

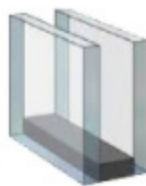

#### Zo-e-shield 5E

##### Plus Room Side Low-E

- Combination of two low-e coatings
- Significantly improved energy efficiency
- Complies with northern Energy Star guidelines with Interior Lo-EIR® coating

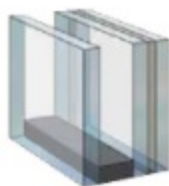

#### Zo-e-shield 6

##### Zo-e-shield 5 Plus Laminated Interior

- Best resistance available to the sun's heat
- Minimizes glare and visible light transmittance
- Superior sound control and UV protection

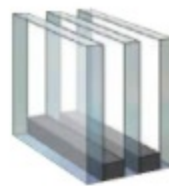

#### Zo-e-shield 7

##### Triple Glazed with 5 Coats of Low-E

- Great insulating value
- Controls glare and blocks the sun's heat in warmer months
- Excellent for use in all climate regions

### Energy Star

As a proud ENERGY STAR® partner, Weather Shield products are rated, certified and labeled for U-Value and Solar Heat Gain by the National Fenestration Rating Council (NFRC). Many of Weather Shield® windows not only meet, but exceed ENERGY STAR® standards for energy efficient windows and doors. Using ENERGY STAR® windows can also help you save money through various tax rebates and incentives.



The ENERGY STAR® criteria for residential windows and doors are tailored to four Climate Zones. A product's energy efficiency for a given climate is based on its impact on heat gain and loss in cold weather and heat gain in warm weather. Check to see what ENERGY STAR® climate zone you live in utilizing the climate map above.

## SCREEN & TRIM OPTIONS



## SCREEN AND TRIM OPTIONS

Weather Shield's high-visibility screen options maximize your view and allow more light to flow in. Then add unparalleled design flexibility and customization with our wood interior and aluminum exterior trim options. Available for curved and angle-shaped windows and doors, adding distinctive architectural detail.

### Screen Options

Screens allow you to enjoy fresh air flow throughout your home all while keeping out pesky insects. Our High-Visibility, No See-um screen cloth utilizes a much finer mesh that offers more air flow along with better optical clarity. Also available in aluminum, non-glare mesh.

### Retractable and Wood Screen

Our **retractable screen** offers unmatched operation with a fully concealed screen channel that maximizes your viewing area. Engineered brake system allows for hands free operation and smooth screen retraction with fully concealed screen components creating a tailored upscale aesthetic.

Hinged from the side, and easily removed for repairs or maintenance, our **wood hinged screen** option welcomes the natural wood character into your home.



NO SEE-UM MESH



ALUMINUM NON-GLARE MESH



WOODHINGED SCREEN

### Exterior Trim Options

Our exterior trim accessories allow for a clean and finished exterior look. Available in any of our standard, designer, radiant metallic, or anodized aluminum finishes, these exterior casings add an ideal finishing touch.



ALUMINUM BRONZED



7/8" ALUMINUM BRONZED



3/16" ALUMINUM FLAT CASING



ALUMINUM HISTORICAL BRONZED



1" BALL NOSE



2" BALL NOSE



1" FULL ROUND BALL NOSE

### Interior Trim Options

Available in any of our rich wood interiors and finishes, these trims are expertly dried, milled and jointed together reflecting the quality you expect.



WM27 (2-1/4")



WM36 (2-1/4")



WM66 (2-1/4")



WM376 (2-1/4")



WM251 (2-1/2")



WM44 (3-1/4")



WM45 (3-1/4")



WM50K CASING (3-1/2")



FLAT CASING (3-1/2")



ROSETTE (SMALL AND LARGE AVAILABLE)

### Commercial Custom Design Solutions

Weather Shield specializes in engineering the perfect solution for your unique window and door challenges. From the replication of historical trim to the creation of custom aluminum extrusions, Weather Shield has the expertise to ensure the success of your next commercial project:

- Custom aluminum extrusions
- Specialized paint and anodized finishing

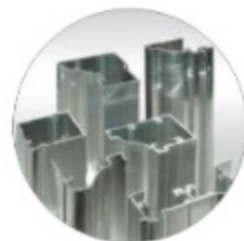



A1

A2

A3

A4

A5

A6

A7

A8

A9

A10

A11

A1 Interior

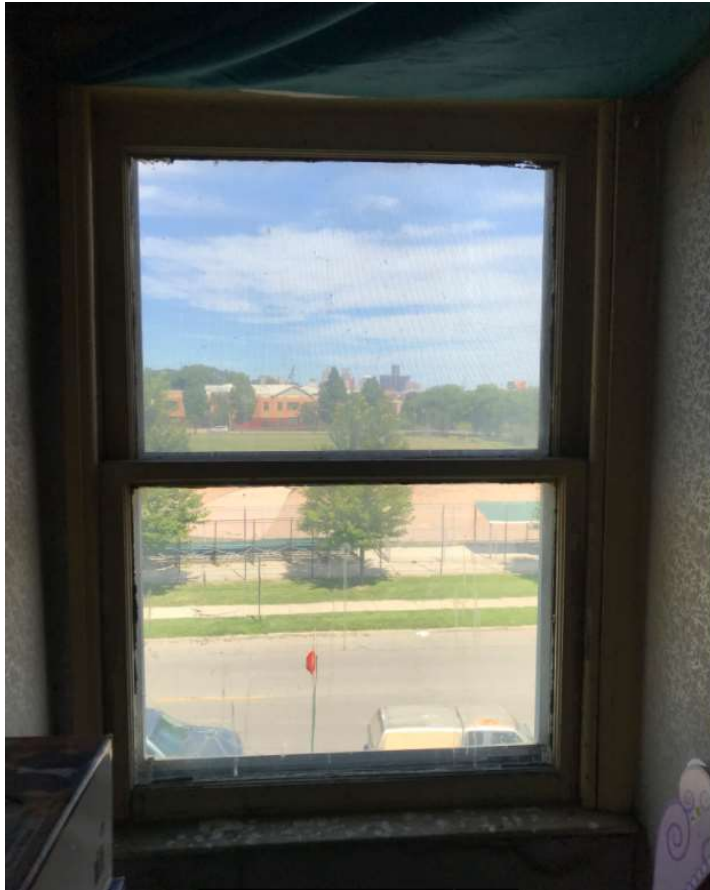

A2 Interior



A3 Interior



A3 Interior



A5 Interior

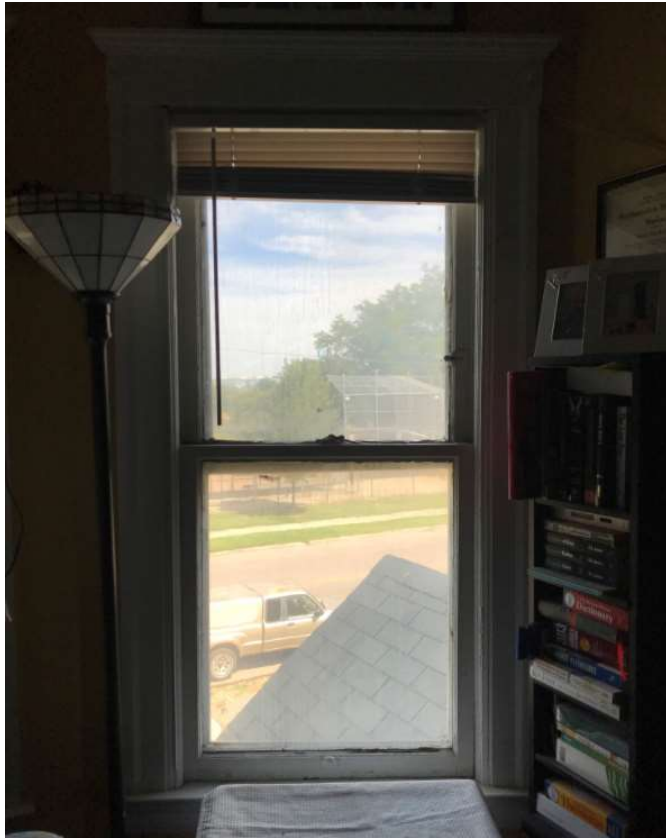

A6 Interior



A7 Interior



A8 Interior

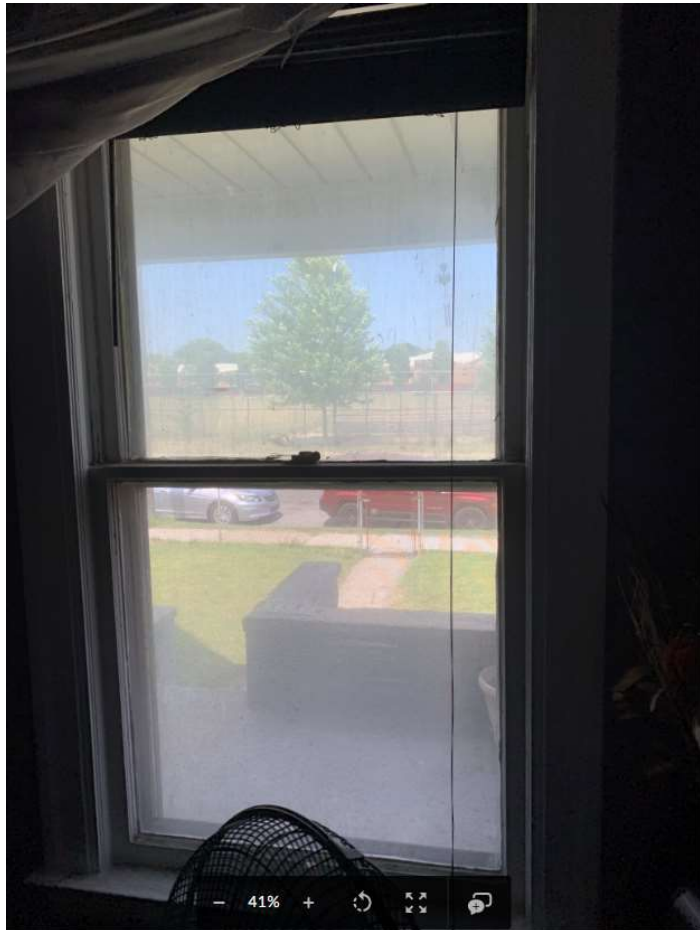

A9 Interior





A10 Interior



A11 Interior

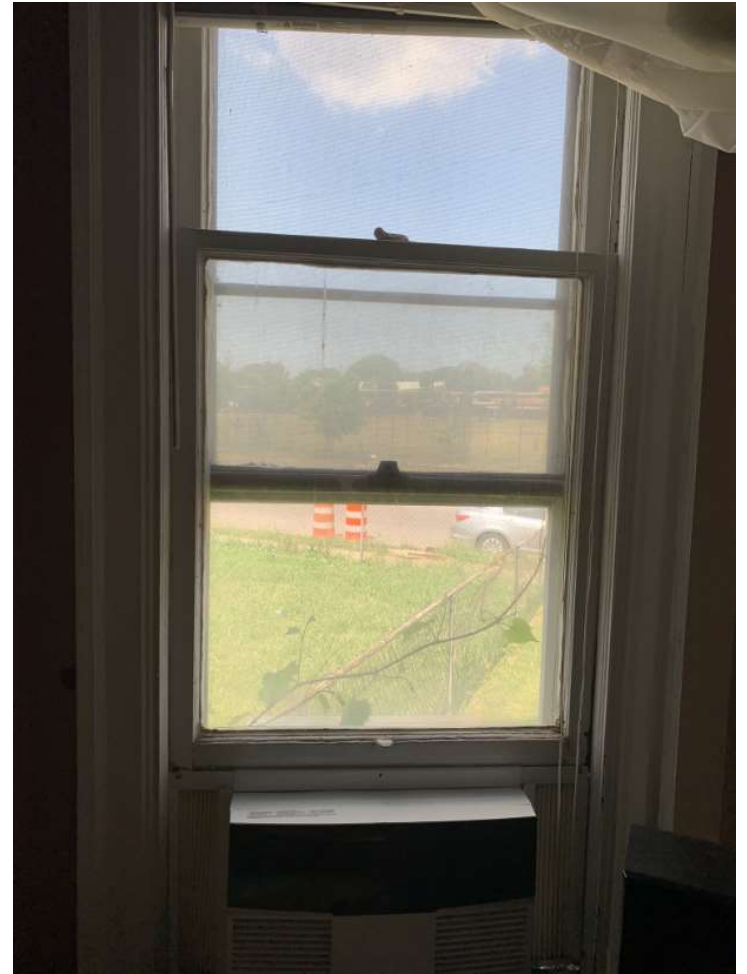



B5

B4

B3

B1

B2

1041

B1 Interior



B2 Interior



B3 Interior



B4 Interior



B5 Interior





C1

C2

C3

C4

C5

C1 Interior



C2 Interior

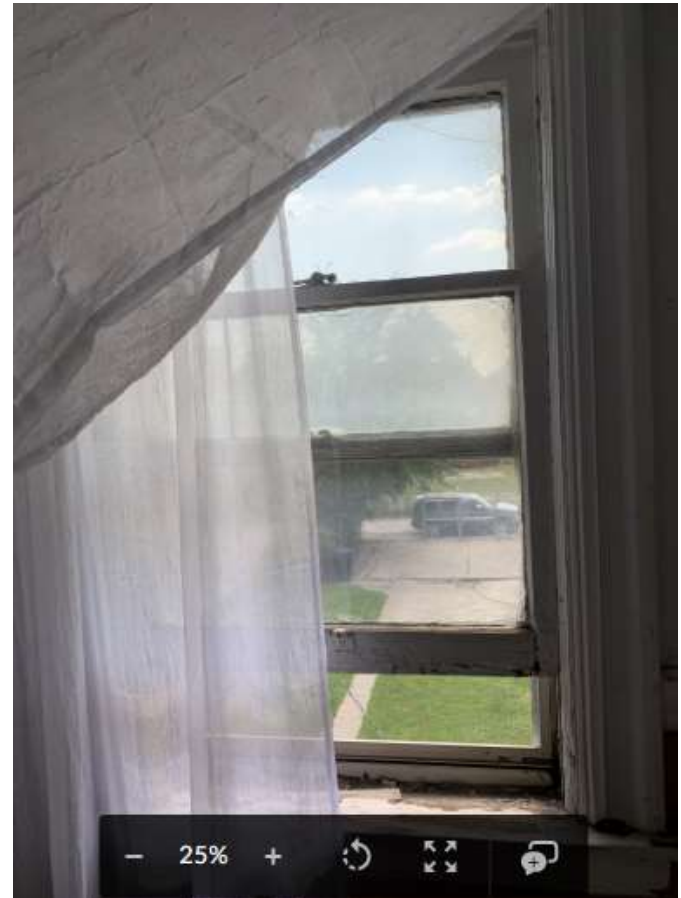

C3 Interior



C4 Interior





C5 Interior



# WEATHER SHIELD.

## WINDOWS & DOORS

P.O. Box 309 Medford, WI 54451  
weathershield.com

# QUOTE

Printed: 08/05/2020 05:22 PM  
Project Date: 08/05/2020

Quote #: 2389337  
Quote Date: 08/05/2020  
WSOneSource 1.0

Sold To: 59377  
DMC GROUP  
13500 FOLEY ST  
DETROIT, MI 48227

Ship To: 59377  
DMC GROUP

Delivery Instructions:

Deliver To:

LINE #	QUANTITY	ATTRIBUTES	UNIT	EXTENDED
--------	----------	------------	------	----------

1	2	P.O.: Location: FRONT FOYER/DINING ROOM Job: 1041 CLARK		
---	---	------------------------------------------------------------------	--	--

**A8 & C4**

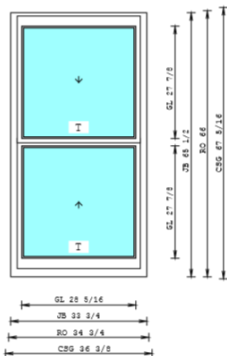

Weather Shield Double Hung Tilt Rectangle 610 1 Wide Complete Unit  
 ----- Mfg Date 8/8/2008 to Present  
 ----- Frame Style Double Hung  
 See weathershield.com for PG/DP information  
 Sizing Method Jb to Jb/Frame Size - Even  
 ----- R/O Size 34 3/4" X 66"  
 ----- Jamb Size 33 3/4" X 65 1/2"  
 Venting R/O - Top 33" Venting R/O - Btm 33"  
 ----- Glass Size - Top 28 5/16" X 27 7/8" - Bottom 28 5/16" X 27 7/8"  
 Operating Code - Operating  
 Poly - - White  
 ----- Exterior Panel/Sash Color White  
 - Factory Applied  
 ----- Standard Sillnose -  
 ----- 5 1/2" Installation Clips - Factory Applied  
 4 9/16" Jamb Depth -  
 Pine - Prefinished White  
 ----- White Vinyl Jamb Liner  
 Insulated Low E  
 ----- W/Out Neat Clean Glass  
 Glazing Bead Type - Colonial  
 ----- W/Out Protective Film  
 ----- Tempered All Sash  
 ----- Silver Spacer  
 ----- W/Inert Airspace Gas  
 1 Lite -  
 White - Double Locks -  
 ----- No Jamb Jack Screws  
 W/Full Screen - White - NO-SEE-UM Mesh - Shipped Loose  
 Standard Unit  
 No Field Prepping

(Viewed from Exterior)

Rough Opening 34-3/4" x 66"  
Overall Jamb 33-3/4" x 65-1/2"

Lead Time: 5 Weeks

# WEATHER SHIELD.

## WINDOWS & DOORS

P.O. Box 309 Medford, WI 54451  
weathershield.com

# QUOTE

Printed: 08/05/2020 05:22 PM  
Project Date: 08/05/2020

Quote #: 2389337  
Quote Date: 08/05/2020  
WSOneSource 1.0

LINE #	QUANTITY	ATTRIBUTES	UNIT	EXTENDED
--------	----------	------------	------	----------

2                      2                      P.O.:  
Location: FRONT FOYER  
Job: 1041 CLARK

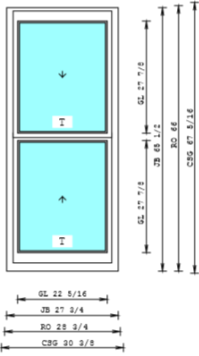

Weather Shield Double Hung Tilt Rectangle 610 1 Wide Complete Unit  
 ----- Mfg Date 8/8/2008 to Present  
 ----- Frame Style Double Hung  
 See weathershield.com for PG/DP information  
 Sizing Method Jb to Jb/Frame Size - Even  
 ----- R/O Size 28 3/4" X 66"  
 ----- Jamb Size 27 3/4" X 65 1/2"  
 Venting R/O - Top 33" Venting R/O - Btm 33"  
 ----- Glass Size - Top 22 5/16" X 27 7/8" - Bottom 22 5/16" X 27 7/8"  
 Operating Code - Operating  
 Poly - - White  
 ----- Exterior Panel/Sash Color White  
 - Factory Applied  
 ----- Standard Sillnose -  
 ----- 5 1/2" Installation Clips - Factory Applied  
 4 9/16" Jamb Depth -  
 Pine - Prefinished White  
 ----- White Vinyl Jamb Liner  
 Insulated Low E  
 ----- W/Out Neat Clean Glass  
 Glazing Bead Type - Colonial  
 ----- W/Out Protective Film  
 ----- Tempered All Sash  
 ----- Silver Spacer  
 ----- W/Inert Airspace Gas  
 1 Lite -  
 White - Double Locks -  
 ----- No Jamb Jack Screws  
 W/Full Screen - White - NO-SEE-UM Mesh - Shipped Loose  
 Standard Unit  
 No Field Prepping

**A9 & A11**

(Viewed from Exterior)

Rough Opening 28-3/4" x 66"  
Overall Jamb 27-3/4" x 65-1/2"

Lead Time: 5 Weeks

# WEATHER SHIELD.

## WINDOWS & DOORS

P.O. Box 309 Medford, WI 54451  
weathershield.com

# QUOTE

Printed: 09/23/2020 09:05 AM  
Project Date: 09/23/2020

Quote #: 2389337  
Quote Date: 08/05/2020  
WSOneSource 1.0

LINE #	QUANTITY	ATTRIBUTES	UNIT	EXTENDED
--------	----------	------------	------	----------

3 1 P.O.:  
Location: LIVING ROOM  
Job: 1041 CLARK

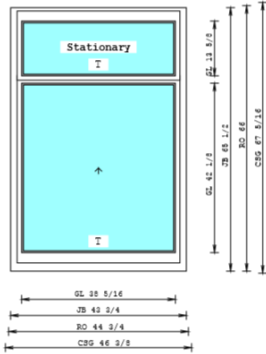

Weather Shield Double Hung Tilt Rectangle 610 1 Wide Complete Unit  
 ----- Mfg Date 8/8/2008 to Present  
 ----- Frame Style Double Hung  
 See weathershield.com for PG/DP information  
 Sizing Method Jb to Jb/Frame Size - Custom Cottage Venting  
 ----- R/O Size 44 3/4" X 66"  
 ----- Jamb Size 43 3/4" X 65 1/2"  
 ----- Venting Jb to Jb - Top 18 1/2" Venting Jb to Jb - Btm 47" Venting R/O - Top 18 3/4" Venting R/  
 ----- Glass Size - Top 38 5/16" X 13 5/8" - Bottom 38 5/16" X 42 1/8"  
 Operating Code - Top Sash Stationary  
 Primed - - Primed  
 ----- Exterior Panel/Sash Color Primed  
 - Factory Applied  
 ----- Standard Sillnose -  
 ----- 5 1/2" Installation Clips - Factory Applied  
 4 9/16" Jamb Depth -  
 Pine - Prefinished White  
 ----- White Vinyl Jamb Liner  
 Insulated Low E  
 ----- W/Out Neat Clean Glass  
 Glazing Bead Type - Colonial  
 ----- W/Out Protective Film  
 ----- Tempered All Sash  
 ----- Silver Spacer  
 ----- W/Inert Airspace Gas  
 1 Lite -  
 White - Double Locks -  
 ----- No Jamb Jack Screws  
 W/Full Screen - White - NO-SEE-UM Mesh - Shipped Loose  
 Standard Unit  
 No Field Prepping

**A10**

(Viewed from Exterior)

Rough Opening 44-3/4" x 66"  
Overall Jamb 43-3/4" x 65-1/2"

Lead Time: 4 Weeks

# WEATHER SHIELD.

## WINDOWS & DOORS

P.O. Box 309 Medford, WI 54451  
weathershield.com

# QUOTE

Printed: 08/05/2020 05:22 PM  
Project Date: 08/05/2020

Quote #: 2389337  
Quote Date: 08/05/2020  
WSOneSource 1.0

LINE #	QUANTITY	ATTRIBUTES	UNIT	EXTENDED
--------	----------	------------	------	----------

4                      2                      P.O.:  
Location: DINING ROOM  
Job: 1041 CLARK

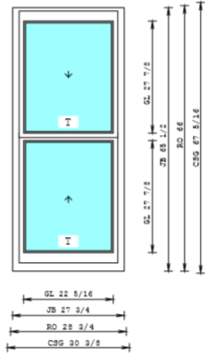

Weather Shield Double Hung Tilt Rectangle 610 1 Wide  
Complete Unit  
---- Mfg Date 8/8/2008 to Present  
---- Frame Style Double Hung  
See weathershield.com for PG/DP information  
Sizing Method Jb to Jb/Frame Size - Even  
---- R/O Size 28 3/4" X 66"  
---- Jamb Size 27 3/4" X 65 1/2"  
Venting R/O - Top 33" Venting R/O - Btm 33"  
---- Glass Size - Top 22 5/16" X 27 7/8" - Bottom 22 5/16" X 27 7/8"  
Operating Code - Operating  
Poly - - White  
---- Exterior Panel/Sash Color White  
- Factory Applied  
---- Standard Sillnose -  
---- 5 1/2" Installation Clips - Factory Applied  
4 9/16" Jamb Depth -  
Pine - Prefinished White  
---- White Vinyl Jamb Liner  
Insulated Low E  
---- W/Out Neat Clean Glass  
Glazing Bead Type - Colonial  
---- W/Out Protective Film  
---- Tempered All Sash  
---- Silver Spacer  
---- W/Inert Airspace Gas  
1 Lite -  
White - Double Locks -  
---- No Jamb Jack Screws  
W/Full Screen - White - NO-SEE-UM Mesh - Shipped Loose  
Standard Unit  
No Field Prepping

**C3**

(Viewed from Exterior)

Rough Opening 28-3/4" x 66"  
Overall Jamb 27-3/4" x 65-1/2"

Lead Time: 5 Weeks

# WEATHER SHIELD.

## WINDOWS & DOORS

P.O. Box 309 Medford, WI 54451  
weathershield.com

# QUOTE

Printed: 08/05/2020 05:22 PM  
Project Date: 08/05/2020

Quote #: 2389337  
Quote Date: 08/05/2020  
WSOneSource 1.0

LINE #	QUANTITY	ATTRIBUTES	UNIT	EXTENDED
--------	----------	------------	------	----------

5                      1                      P.O.:  
Location: BATHROOM  
Job: 1041 CLARK

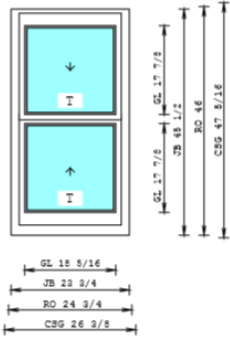

Weather Shield Double Hung Tilt Rectangle 610 1 Wide Complete Unit  
 ----- Mfg Date 8/8/2008 to Present  
 ----- Frame Style Double Hung  
 See weathershield.com for PG/DP information  
 Sizing Method Jb to Jb/Frame Size - Even  
 ----- R/O Size 24 3/4" X 46"  
 ----- Jamb Size 23 3/4" X 45 1/2"  
 Venting R/O - Top 23" Venting R/O - Btm 23"  
 ----- Glass Size - Top 18 5/16" X 17 7/8" - Bottom 18 5/16" X 17 7/8"  
 Operating Code - Operating  
 Poly - - White  
 ----- Exterior Panel/Sash Color White  
 - Factory Applied  
 ----- Standard Sillnose -  
 ----- 5 1/2" Installation Clips - Factory Applied  
 4 9/16" Jamb Depth -  
 Pine - Prefinished White  
 ----- White Vinyl Jamb Liner  
 Insulated Low E  
 ----- W/Out Neat Clean Glass  
 Glazing Bead Type - Colonial  
 ----- W/Out Protective Film  
 ----- Obscure  
 ----- Tempered All Sash  
 ----- Silver Spacer  
 ----- W/Inert Airspace Gas  
 1 Lite -  
 White - Single Lock -  
 ----- No Jamb Jack Screws  
 W/Full Screen - White - NO-SEE-UM Mesh - Shipped Loose  
 Standard Unit  
 No Field Prepping

**C4**

(Viewed from Exterior)

Rough Opening 24-3/4" x 46"  
Overall Jamb 23-3/4" x 45-1/2"

Lead Time: 5 Weeks

# WEATHER SHIELD.

## WINDOWS & DOORS

P.O. Box 309 Medford, WI 54451  
weathershield.com

# QUOTE

Printed: 09/24/2020 12:48 PM  
Project Date: 09/23/2020

Quote #: 2389337  
Quote Date: 08/05/2020  
WSOneSource 1.0

LINE #	QUANTITY	ATTRIBUTES	UNIT	EXTENDED
--------	----------	------------	------	----------

6 1 P.O.:  
Location: KITCHEN  
Job: 1041 CLARK

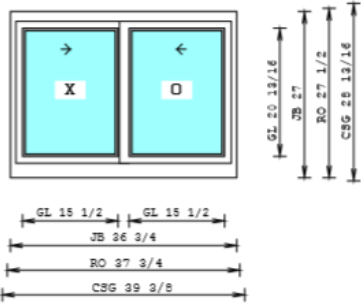

Weather Shield Double Slider Rectangle 6401 1 Wide Complete Unit  
---- Mfg Date 8/1/2006 to Present  
---- Frame Style Slider  
See weathershield.com for PG/DP information  
Sizing Method Jb to Jb/Frame Size  
---- R/O Size 37 3/4" X 27 1/2"  
---- Jamb Size 36 3/4" X 27"  
---- Glass Size - Active 15 1/2" X 20 13/16" - Inactive 15 1/2" X 20 13/16"  
Operating Code - XO  
Primed - - Primed  
---- Exterior Panel/Sash Color Primed  
- Factory Applied  
---- Standard Sillnose -  
---- 5 1/2" Installation Clips - Factory Applied  
4 9/16" Jamb Depth -  
Pine - Prefinished White  
---- White Vinyl Jamb Liner  
Insulated Low E  
---- W/Out Neat Clean Glass  
Glazing Bead Type - Colonial  
---- W/Out Protective Film  
---- Silver Spacer  
---- W/Inert Airspace Gas  
1 Lite -  
White - Single Lock -  
W/Full Screen - White - NO-SEE-UM Mesh - Shipped Loose  
Standard Unit  
No Field Prepping

(Viewed from Exterior)

Rough Opening 37-3/4" x 27-1/2"  
Overall Jamb 36-3/4" x 27"

Lead Time: 4 Weeks

# WEATHER SHIELD.

## WINDOWS & DOORS

P.O. Box 309 Medford, WI 54451  
weathershield.com

# QUOTE

Printed: 08/05/2020 05:22 PM  
Project Date: 08/05/2020

Quote #: 2389337  
Quote Date: 08/05/2020  
WSOneSource 1.0

LINE #	QUANTITY	ATTRIBUTES	UNIT	EXTENDED
--------	----------	------------	------	----------

7                    1                    P.O.:  
Location: KITCHEN  
Job: 1041 CLARK

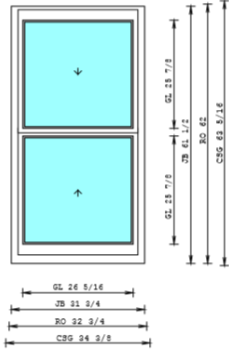

Weather Shield Double Hung Tilt Rectangle 610 1 Wide  
Complete Unit  
---- Mfg Date 8/8/2008 to Present  
---- Frame Style Double Hung  
See weathershield.com for PG/DP information  
Sizing Method Jb to Jb/Frame Size - Even  
---- R/O Size 32 3/4" X 62"  
---- Jamb Size 31 3/4" X 61 1/2"  
Venting R/O - Top 31" Venting R/O - Btm 31"  
---- Glass Size - Top 26 5/16" X 25 7/8" - Bottom 26 5/16" X 25 7/8"  
Operating Code - Operating  
Poly - - White  
---- Exterior Panel/Sash Color White  
- Factory Applied  
---- Standard Sillnose -  
---- 5 1/2" Installation Clips - Factory Applied  
4 9/16" Jamb Depth -  
Pine - Prefinished White  
---- White Vinyl Jamb Liner  
Insulated Low E  
---- W/Out Neat Clean Glass  
Glazing Bead Type - Colonial  
---- W/Out Protective Film  
---- Silver Spacer  
---- W/Inert Airspace Gas  
1 Lite -  
White - Single Lock -  
---- No Jamb Jack Screws  
W/Full Screen - White - NO-SEE-UM Mesh - Shipped Loose  
Standard Unit  
No Field Prepping

**B2**

(Viewed from Exterior)

Rough Opening 32-3/4" x 62"  
Overall Jamb 31-3/4" x 61-1/2"

Lead Time: 5 Weeks



# WEATHER SHIELD.

## WINDOWS & DOORS

P.O. Box 309 Medford, WI 54451  
weathershield.com

# QUOTE

Printed: 08/05/2020 05:22 PM  
Project Date: 08/05/2020

Quote #: 2389337  
Quote Date: 08/05/2020  
WSOneSource 1.0

LINE #	QUANTITY	ATTRIBUTES	UNIT	EXTENDED
--------	----------	------------	------	----------

8                    1                    P.O.:  
Location: KITCHEN  
Job: 1041 CLARK

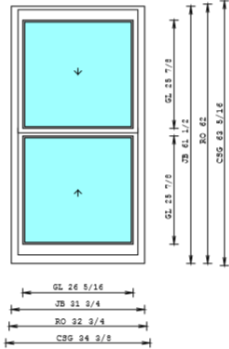

Weather Shield Double Hung Tilt Rectangle 610 1 Wide  
Complete Unit  
---- Mfg Date 8/8/2008 to Present  
---- Frame Style Double Hung  
See weathershield.com for PG/DP information  
Sizing Method Jb to Jb/Frame Size - Even  
---- R/O Size 32 3/4" X 62"  
---- Jamb Size 31 3/4" X 61 1/2"  
Venting R/O - Top 31" Venting R/O - Btm 31"  
---- Glass Size - Top 26 5/16" X 25 7/8" - Bottom 26 5/16" X 25 7/8"  
Operating Code - Operating  
Poly - - White  
---- Exterior Panel/Sash Color White  
- Factory Applied  
---- Standard Sillnose -  
---- 5 1/2" Installation Clips - Factory Applied  
4 9/16" Jamb Depth -  
Pine - Prefinished White  
---- White Vinyl Jamb Liner  
Insulated Low E  
---- W/Out Neat Clean Glass  
Glazing Bead Type - Colonial  
---- W/Out Protective Film  
---- Silver Spacer  
---- W/Inert Airspace Gas  
1 Lite -  
White - Single Lock -  
---- No Jamb Jack Screws  
W/Full Screen - White - NO-SEE-UM Mesh - Shipped Loose  
Standard Unit  
No Field Prepping

**B1**

(Viewed from Exterior)

Rough Opening 32-3/4" x 62"  
Overall Jamb 31-3/4" x 61-1/2"

Lead Time: 5 Weeks

# WEATHER SHIELD.

## WINDOWS & DOORS

P.O. Box 309 Medford, WI 54451  
weathershield.com

# QUOTE

Printed: 08/05/2020 05:22 PM  
Project Date: 08/05/2020

Quote #: 2389337  
Quote Date: 08/05/2020  
WSOneSource 1.0

LINE #	QUANTITY	ATTRIBUTES	UNIT	EXTENDED
--------	----------	------------	------	----------

9                      2                      P.O.:  
Location: STAIRCASE  
Job: 1041 CLARK

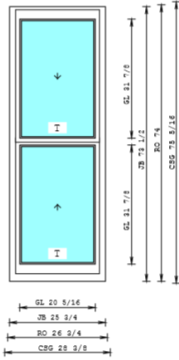

Weather Shield Double Hung Tilt Rectangle 610 1 Wide Complete Unit  
 ----- Mfg Date 8/8/2008 to Present  
 ----- Frame Style Double Hung  
 See weathershield.com for PG/DP information  
 Sizing Method Jb to Jb/Frame Size - Even  
 ----- R/O Size 26 3/4" X 74"  
 ----- Jamb Size 25 3/4" X 73 1/2"  
 Venting R/O - Top 37" Venting R/O - Btm 37"  
 ----- Glass Size - Top 20 5/16" X 31 7/8" - Bottom 20 5/16" X 31 7/8"  
 Operating Code - Operating  
 Poly - - White  
 ----- Exterior Panel/Sash Color White  
 - Factory Applied  
 ----- Standard Sillnose -  
 ----- 5 1/2" Installation Clips - Factory Applied  
 4 9/16" Jamb Depth -  
 Pine - Prefinished White  
 ----- White Vinyl Jamb Liner  
 Insulated Low E  
 ----- W/Out Neat Clean Glass  
 Glazing Bead Type - Colonial  
 ----- W/Out Protective Film  
 ----- Tempered All Sash  
 ----- Silver Spacer  
 ----- W/Inert Airspace Gas  
 1 Lite -  
 White - Single Lock -  
 ----- No Jamb Jack Screws  
 W/Full Screen - White - NO-SEE-UM Mesh - Shipped Loose  
 Standard Unit  
 No Field Prepping

**B3 & B4**

(Viewed from Exterior)

Rough Opening 26-3/4" x 74"  
Overall Jamb 25-3/4" x 73-1/2"

Lead Time: 5 Weeks

# WEATHER SHIELD.

## WINDOWS & DOORS

P.O. Box 309 Medford, WI 54451  
weathershield.com

# QUOTE

Printed: 08/05/2020 05:22 PM  
Project Date: 08/05/2020

Quote #: 2389337  
Quote Date: 08/05/2020  
WSOneSource 1.0

LINE #	QUANTITY	ATTRIBUTES	UNIT	EXTENDED
--------	----------	------------	------	----------

10                    2                    P.O.:  
Location: BEDROOM  
Job: 1041 CLARK

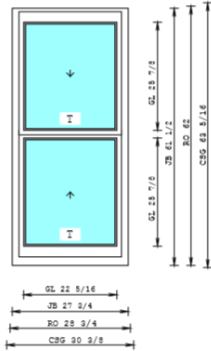

Weather Shield Double Hung Tilt Rectangle 610 1 Wide Complete Unit  
 ---- Mfg Date 8/8/2008 to Present  
 ---- Frame Style Double Hung  
 See weathershield.com for PG/DP information  
 Sizing Method Jb to Jb/Frame Size - Even  
 ---- R/O Size 28 3/4" X 62"  
 ---- Jamb Size 27 3/4" X 61 1/2"  
 Venting R/O - Top 31" Venting R/O - Btm 31"  
 ---- Glass Size - Top 22 5/16" X 25 7/8" - Bottom 22 5/16" X 25 7/8"  
 Operating Code - Operating  
 Poly - - White  
 ---- Exterior Panel/Sash Color White  
 - Factory Applied  
 ---- Standard Sillnose -  
 ---- 5 1/2" Installation Clips - Factory Applied  
 4 9/16" Jamb Depth -  
 Pine - Prefinished White  
 ---- White Vinyl Jamb Liner  
 Insulated Low E  
 ---- W/Out Neat Clean Glass  
 Glazing Bead Type - Colonial  
 ---- W/Out Protective Film  
 ---- Tempered All Sash  
 ---- Silver Spacer  
 ---- W/Inert Airspace Gas  
 1 Lite -  
 White - Single Lock -  
 ---- No Jamb Jack Screws  
 W/Full Screen - White - NO-SEE-UM Mesh - Shipped Loose  
 Standard Unit  
 No Field Prepping

**A5 & A7**

(Viewed from Exterior)

Rough Opening 28-3/4" x 62"  
Overall Jamb 27-3/4" x 61-1/2"

Lead Time: 5 Weeks

# WEATHER SHIELD.

## WINDOWS & DOORS

P.O. Box 309 Medford, WI 54451  
weathershield.com

# QUOTE

Printed: 08/05/2020 05:22 PM  
Project Date: 08/05/2020

Quote #: 2389337  
Quote Date: 08/05/2020  
WSOneSource 1.0

LINE #	QUANTITY	ATTRIBUTES	UNIT	EXTENDED
--------	----------	------------	------	----------

11                    1                    P.O.:  
Location: BATHROOM  
Job: 1041 CLARK

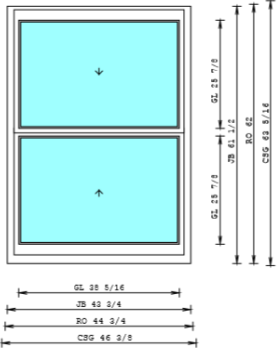

Weather Shield Double Hung Tilt Rectangle 610 1 Wide  
Complete Unit  
---- Mfg Date 8/8/2008 to Present  
---- Frame Style Double Hung  
See weathershield.com for PG/DP information  
Sizing Method Jb to Jb/Frame Size - Even  
---- R/O Size 44 3/4" X 62"  
---- Jamb Size 43 3/4" X 61 1/2"  
Venting R/O - Top 31" Venting R/O - Btm 31"  
---- Glass Size - Top 38 5/16" X 25 7/8" - Bottom 38 5/16" X 25 7/8"  
Operating Code - Operating  
Poly - - White  
---- Exterior Panel/Sash Color White  
- Factory Applied  
---- Standard Sillnose -  
---- 5 1/2" Installation Clips - Factory Applied  
4 9/16" Jamb Depth -  
Pine - Prefinished White  
---- White Vinyl Jamb Liner  
Insulated Low E  
---- W/Out Neat Clean Glass  
Glazing Bead Type - Colonial  
---- W/Out Protective Film  
---- Obscure  
---- Silver Spacer  
---- W/Inert Airspace Gas  
1 Lite -  
White - Double Locks -  
---- No Jamb Jack Screws  
W/Full Screen - White - NO-SEE-UM Mesh - Shipped Loose  
Standard Unit  
No Field Prepping

**A6**

(Viewed from Exterior)

Rough Opening 44-3/4" x 62"  
Overall Jamb 43-3/4" x 61-1/2"

Lead Time: 5 Weeks

# WEATHER SHIELD.

## WINDOWS & DOORS

P.O. Box 309 Medford, WI 54451  
weathershield.com

# QUOTE

Printed: 08/05/2020 05:22 PM  
Project Date: 08/05/2020

Quote #: 2389337  
Quote Date: 08/05/2020  
WSOneSource 1.0

LINE #	QUANTITY	ATTRIBUTES	UNIT	EXTENDED
--------	----------	------------	------	----------

12                      2                      P.O.:  
Location: BEDROOM  
Job: 1041 CLARK

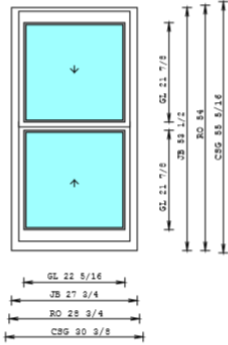

Weather Shield Double Hung Tilt Rectangle 610 1 Wide Complete Unit  
 ----- Mfg Date 8/8/2008 to Present  
 ----- Frame Style Double Hung  
 See weathershield.com for PG/DP information  
 Sizing Method Jb to Jb/Frame Size - Even  
 ----- R/O Size 28 3/4" X 54"  
 ----- Jamb Size 27 3/4" X 53 1/2"  
 Venting R/O - Top 27" Venting R/O - Btm 27"  
 ----- Glass Size - Top 22 5/16" X 21 7/8" - Bottom 22 5/16" X 21 7/8"  
 Operating Code - Operating  
 Poly - - White  
 ----- Exterior Panel/Sash Color White  
 - Factory Applied  
 ----- Standard Sillnose -  
 ----- 5 1/2" Installation Clips - Factory Applied  
 4 9/16" Jamb Depth -  
 Pine - Prefinished White  
 ----- White Vinyl Jamb Liner  
 Insulated Low E  
 ----- W/Out Neat Clean Glass  
 Glazing Bead Type - Colonial  
 ----- W/Out Protective Film  
 ----- Silver Spacer  
 ----- W/Inert Airspace Gas  
 1 Lite -  
 White - Single Lock -  
 ----- No Jamb Jack Screws  
 W/Full Screen - White - NO-SEE-UM Mesh - Shipped Loose  
 Standard Unit  
 No Field Prepping

**A3 & A4**

(Viewed from Exterior)

Rough Opening 28-3/4" x 54"  
Overall Jamb 27-3/4" x 53-1/2"

Lead Time: 5 Weeks

# WEATHER SHIELD.

## WINDOWS & DOORS

P.O. Box 309 Medford, WI 54451  
weathershield.com

# QUOTE

Printed: 08/05/2020 05:22 PM  
Project Date: 08/05/2020

Quote #: 2389337  
Quote Date: 08/05/2020  
WSOneSource 1.0

LINE #	QUANTITY	ATTRIBUTES	UNIT	EXTENDED
--------	----------	------------	------	----------

13                      1                      P.O.:  
Location: BATHROOM  
Job: 1041 CLARK

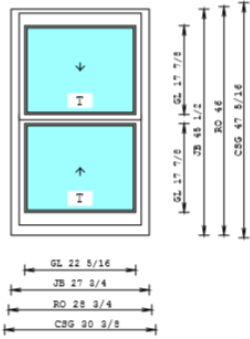

Weather Shield Double Hung Tilt Rectangle 610 1 Wide  
Complete Unit  
---- Mfg Date 8/8/2008 to Present  
---- Frame Style Double Hung  
See weathershield.com for PG/DP information  
Sizing Method Jb to Jb/Frame Size - Even  
---- R/O Size 28 3/4" X 46"  
---- Jamb Size 27 3/4" X 45 1/2"  
Venting R/O - Top 23" Venting R/O - Btm 23"  
---- Glass Size - Top 22 5/16" X 17 7/8" - Bottom 22 5/16" X 17 7/8"  
Operating Code - Operating  
Poly - - White  
---- Exterior Panel/Sash Color White  
- Factory Applied  
---- Standard Sillnose -  
---- 5 1/2" Installation Clips - Factory Applied  
4 9/16" Jamb Depth -  
Pine - Prefinished White  
---- White Vinyl Jamb Liner  
Insulated Low E  
---- W/Out Neat Clean Glass  
Glazing Bead Type - Colonial  
---- W/Out Protective Film  
---- Obscure  
---- Tempered All Sash  
---- Silver Spacer  
---- W/Inert Airspace Gas  
1 Lite -  
White - Single Lock -  
---- No Jamb Jack Screws  
W/Full Screen - White - NO-SEE-UM Mesh - Shipped Loose  
Standard Unit  
No Field Prepping

**C2**

(Viewed from Exterior)

Rough Opening 28-3/4" x 46"  
Overall Jamb 27-3/4" x 45-1/2"

Lead Time: 5 Weeks

# WEATHER SHIELD.

## WINDOWS & DOORS

P.O. Box 309 Medford, WI 54451  
weathershield.com

# QUOTE

Printed: 08/05/2020 05:22 PM  
Project Date: 08/05/2020

Quote #: 2389337  
Quote Date: 08/05/2020  
WSOneSource 1.0

LINE #	QUANTITY	ATTRIBUTES	UNIT	EXTENDED
--------	----------	------------	------	----------

14                      2                      P.O.:  
Location: BEDROOM  
Job: 1041 CLARK

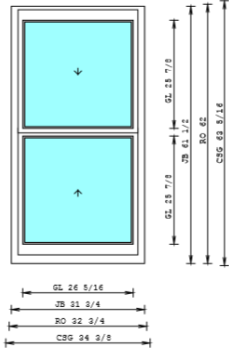

Weather Shield Double Hung Tilt Rectangle 610 1 Wide Complete Unit  
 ----- Mfg Date 8/8/2008 to Present  
 ----- Frame Style Double Hung  
 See weathershield.com for PG/DP information  
 Sizing Method Jb to Jb/Frame Size - Even  
 ----- R/O Size 32 3/4" X 62"  
 ----- Jamb Size 31 3/4" X 61 1/2"  
 Venting R/O - Top 31" Venting R/O - Btm 31"  
 ----- Glass Size - Top 26 5/16" X 25 7/8" - Bottom 26 5/16" X 25 7/8"  
 Operating Code - Operating  
 Poly - - White  
 ----- Exterior Panel/Sash Color White  
 - Factory Applied  
 ----- Standard Sillnose -  
 ----- 5 1/2" Installation Clips - Factory Applied  
 4 9/16" Jamb Depth -  
 Pine - Prefinished White  
 ----- White Vinyl Jamb Liner  
 Insulated Low E  
 ----- W/Out Neat Clean Glass  
 Glazing Bead Type - Colonial  
 ----- W/Out Protective Film  
 ----- Silver Spacer  
 ----- W/Inert Airspace Gas  
 1 Lite -  
 White - Single Lock -  
 ----- No Jamb Jack Screws  
 W/Full Screen - White - NO-SEE-UM Mesh - Shipped Loose  
 Standard Unit  
 No Field Prepping

**C1 & D2**

(Viewed from Exterior)

Rough Opening 32-3/4" x 62"  
Overall Jamb 31-3/4" x 61-1/2"

Lead Time: 5 Weeks

# WEATHER SHIELD.

## WINDOWS & DOORS

P.O. Box 309 Medford, WI 54451  
weathershield.com

# QUOTE

Printed: 08/05/2020 05:22 PM  
Project Date: 08/05/2020

Quote #: 2389337  
Quote Date: 08/05/2020  
WSOneSource 1.0

LINE #	QUANTITY	ATTRIBUTES	UNIT	EXTENDED
--------	----------	------------	------	----------

15                    2                    P.O.:  
Location: ATTIC  
Job: 1041 CLARK

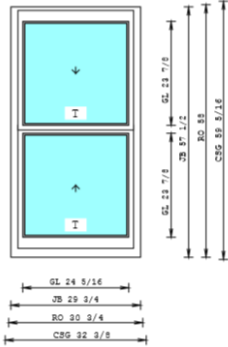

Weather Shield Double Hung Tilt Rectangle 610 1 Wide Complete Unit  
 ---- Mfg Date 8/8/2008 to Present  
 ---- Frame Style Double Hung  
 See weathershield.com for PG/DP information  
 Sizing Method Jb to Jb/Frame Size - Even  
 ---- R/O Size 30 3/4" X 58"  
 ---- Jamb Size 29 3/4" X 57 1/2"  
 Venting R/O - Top 29" Venting R/O - Btm 29"  
 ---- Glass Size - Top 24 5/16" X 23 7/8" - Bottom 24 5/16" X 23 7/8"  
 Operating Code - Operating  
 Poly - - White  
 ---- Exterior Panel/Sash Color White  
 - Factory Applied  
 ---- Standard Sillnose -  
 ---- 5 1/2" Installation Clips - Factory Applied  
 4 9/16" Jamb Depth -  
 Pine - Prefinished White  
 ---- White Vinyl Jamb Liner  
 Insulated Low E  
 ---- W/Out Neat Clean Glass  
 Glazing Bead Type - Colonial  
 ---- W/Out Protective Film  
 ---- Tempered All Sash  
 ---- Silver Spacer  
 ---- W/Inert Airspace Gas  
 1 Lite -  
 White - Single Lock -  
 ---- No Jamb Jack Screws  
 W/Full Screen - White - NO-SEE-UM Mesh - Shipped Loose  
 Standard Unit  
 No Field Prepping

**B5**

(Viewed from Exterior)

Rough Opening 30-3/4" x 58"  
Overall Jamb 29-3/4" x 57-1/2"

Lead Time: 5 Weeks



# WEATHER SHIELD.

## WINDOWS & DOORS

P.O. Box 309 Medford, WI 54451  
weathershield.com

# QUOTE

Printed: 08/05/2020 05:22 PM  
Project Date: 08/05/2020

Quote #: 2389337  
Quote Date: 08/05/2020  
WSOneSource 1.0

LINE #	QUANTITY	ATTRIBUTES	UNIT	EXTENDED
--------	----------	------------	------	----------

16                    1                    P.O.:  
Location: ATTIC  
Job: 1041 CLARK

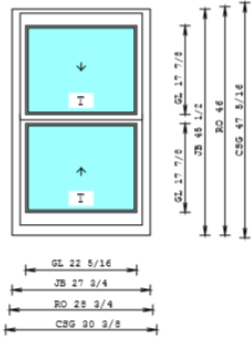

Weather Shield Double Hung Tilt Rectangle 610 1 Wide  
Complete Unit  
---- Mfg Date 8/8/2008 to Present  
---- Frame Style Double Hung  
See weathershield.com for PG/DP information  
Sizing Method Jb to Jb/Frame Size - Even  
---- R/O Size 28 3/4" X 46"  
---- Jamb Size 27 3/4" X 45 1/2"  
Venting R/O - Top 23" Venting R/O - Btm 23"  
---- Glass Size - Top 22 5/16" X 17 7/8" - Bottom 22 5/16" X 17 7/8"  
Operating Code - Operating  
Poly - - White  
---- Exterior Panel/Sash Color White  
- Factory Applied  
---- Standard Sillnose -  
---- 5 1/2" Installation Clips - Factory Applied  
4 9/16" Jamb Depth -  
Pine - Prefinished White  
---- White Vinyl Jamb Liner  
Insulated Low E  
---- W/Out Neat Clean Glass  
Glazing Bead Type - Colonial  
---- W/Out Protective Film  
---- Tempered All Sash  
---- Silver Spacer  
---- W/Inert Airspace Gas  
1 Lite -  
White - Single Lock -  
---- No Jamb Jack Screws  
W/Full Screen - White - NO-SEE-UM Mesh - Shipped Loose  
Standard Unit  
No Field Prepping

(Viewed from Exterior)

Rough Opening 28-3/4" x 46"  
Overall Jamb 27-3/4" x 45-1/2"

Lead Time: 5 Weeks

# WEATHER SHIELD.

## WINDOWS & DOORS

P.O. Box 309 Medford, WI 54451  
weathershield.com

# QUOTE

Printed: 08/05/2020 05:22 PM  
Project Date: 08/05/2020

Quote #: 2389337  
Quote Date: 08/05/2020  
WSOneSource 1.0

LINE #	QUANTITY	ATTRIBUTES	UNIT	EXTENDED
17	1	P.O.: Location: ATTIC Job: 1041 CLARK		

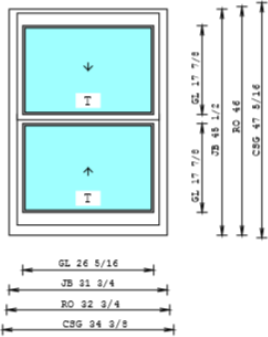

Weather Shield Double Hung Tilt Rectangle 610 1 Wide  
Complete Unit  
---- Mfg Date 8/8/2008 to Present  
---- Frame Style Double Hung  
See weathershield.com for PG/DP information  
Sizing Method Jb to Jb/Frame Size - Even  
---- R/O Size 32 3/4" X 46"  
---- Jamb Size 31 3/4" X 45 1/2"  
Venting R/O - Top 23" Venting R/O - Btm 23"  
---- Glass Size - Top 26 5/16" X 17 7/8" - Bottom 26 5/16" X 17 7/8"  
Operating Code - Operating  
Poly - - White  
---- Exterior Panel/Sash Color White  
- Factory Applied  
---- Standard Sillnose -  
---- 5 1/2" Installation Clips - Factory Applied  
4 9/16" Jamb Depth -  
Pine - Prefinished White  
---- White Vinyl Jamb Liner  
Insulated Low E  
---- W/Out Neat Clean Glass  
Glazing Bead Type - Colonial  
---- W/Out Protective Film  
---- Tempered All Sash  
---- Silver Spacer  
---- W/Inert Airspace Gas  
1 Lite -  
White - Single Lock -  
---- No Jamb Jack Screws  
W/Full Screen - White - NO-SEE-UM Mesh - Shipped Loose  
Standard Unit  
No Field Prepping

(Viewed from Exterior)

Rough Opening 32-3/4" x 46"  
Overall Jamb 31-3/4" x 45-1/2"  
Miscellaneous Charges

Lead Time: 5 Weeks

Thank you for choosing Weather Shield Windows & Doors

# WEATHER SHIELD.

## WINDOWS & DOORS

P.O. Box 309 Medford, WI 54451  
weathershield.com

# Message Summary

Printed: 08/05/2020 05:22 PM  
Project Date: 08/05/2020

Quote #: 2389337  
Quote Date: 08/05/2020  
WSOneSource 1.0

---

<u>Message #</u>	<u>Line Item/s</u>	<u>Message</u>
------------------	--------------------	----------------