

**STAFF REPORT 08-12-2020 REGULAR MEETING**

**PREPARED BY: A. PHILLIPS**

**APPLICATION NUMBER: 20-6803**

**ADDRESS: 1258 WASHINGTON BOULEVARD**

**HISTORIC DISTRICT: WASHINGTON BOULEVARD**

**APPLICANT: JAMES FLORA, DETROIT BEER EXCHANGE, LLC**

**PROPERTY OWNER: KAMPER & STEVENS LDHA, LLC; THE ROXBURY GROUP**

**DATE PROVISIONALLY COMPLETE: 07-27-2020**

**STAFF SITE VISIT: 08-04-2020**

**SCOPE: INSTALL NEW INTERNALLY ILLUMINATED SIGNAGE**

**EXISTING CONDITIONS**

The building located at 1258 Washington Boulevard is an 8-story Renaissance Revival style office building constructed in 1901. The oldest building in the Washington Boulevard Historic District, the structure is clad in red brick with limestone and terra-cotta detailing. Additionally, it features varying window types and an ornate Italian Romanesque cornice. An Art Moderne style façade is featured on the lower levels of the building.



*Photo taken by HDC staff – August 4, 2020*

**PROPOSAL**

With the current proposal, the applicant is seeking the Commission’s approval to **install a new internally illuminated blade sign per the attached drawings and application**. Sign materials and details include:

- Sign to be mounted onto the existing limestone façade at the northwest corner (intersection of Washington Boulevard and Grand River) of the building at a 45° angle with the bottom of the sign located 14’ above grade.
- Sign to be circular in shape – approximately 60” in diameter and 12” thick.

- Sign to be constructed of an aluminum frame (finish color: black) with 3/16” acrylic faces which will have full-color vinyl overlays displaying the Beer Exchange logo.
- Sign will be internally illuminated with LED modules.

### **STAFF OBSERVATIONS & RESEARCH**

- Washington Boulevard Historic District was designated in 2003.

### **ISSUES**

- This blade sign was originally included in the application package for the general rehabilitation of the building that was heard by the Commission and approved on 11/14/2018, however, the sign was approved as *externally* illuminated. The applicant prefers an internally illuminated sign to match the signage at the Detroit Beer Exchange location in Kalamazoo ([see photos in application materials](#)). HDC staff does not have the authority to approve internally illuminated signage, therefore, the applicant chose to submit this modification as a new application to the Commission for review.
- The Kalamazoo Beer Exchange is not located in a local historic district of Kalamazoo, however, it is located in a historic building – the Globe Building which was constructed in the early 1900s.
- The applicant provides photographs of other examples of internally illuminated blade signs on a nearby building within the Washington Boulevard HD in their application materials. Upon further review, it appears that the Starbucks sign was approved in 2017 and the Roast sign was approved in 2009. While it is evident that these types of internally illuminated “box” signs (metal frame with acrylic/vinyl planes) have been approved by the Commission previously, it is staff’s opinion that the combination of material, illumination, and sign design of this type of box sign, is not compatible with the architectural features of the historic building, its site and setting.

### **RECOMMENDATION**

It is staff’s opinion that the combination of the material (acrylic/vinyl), design (metal frame with acrylic faces), and internal illumination is not compatible with the architectural features of the historic building and detracts from the historic integrity of the property. Staff therefore recommends that the Commission deny a Certificate of Appropriateness as the proposed work does not meet the Secretary of the Interior’s Standards for Rehabilitation, especially:

*#2) The historic character of a property shall be retained and preserved. The removal of historic materials or alteration of features and spaces that characterize a property shall be avoided.*

*#9) New additions, exterior alterations, or related new construction shall not destroy historic materials that characterize the property. The new work shall be differentiated from the old and shall be compatible with the massing, size, scale, and architectural features to protect the historic integrity of the property and its environment.*



WOODWARD

GODFREY BLOCK.

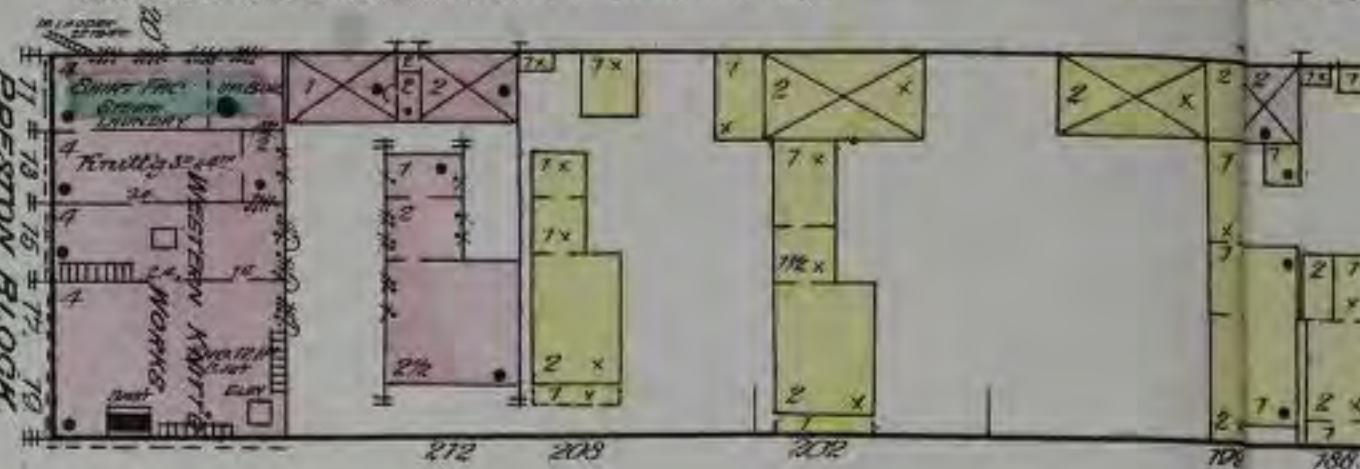
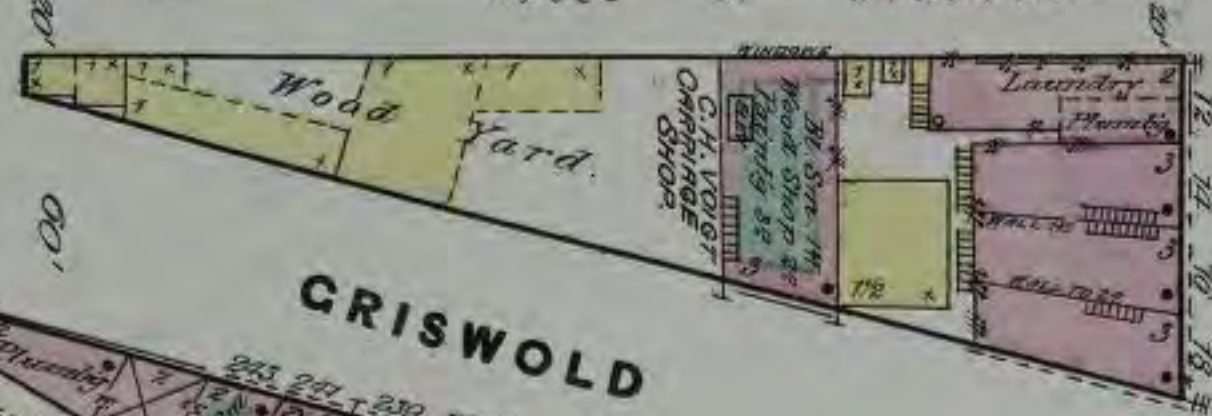
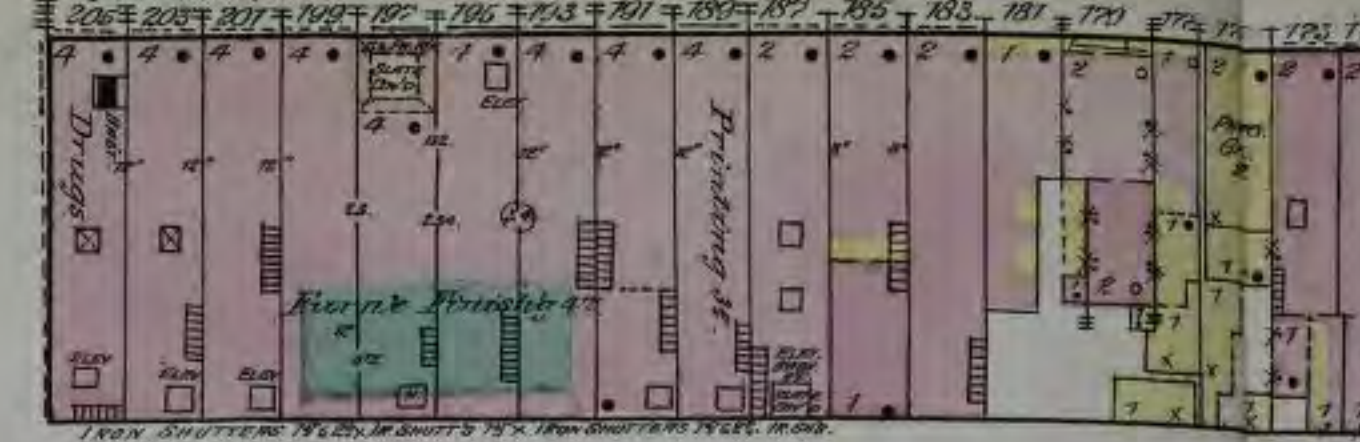
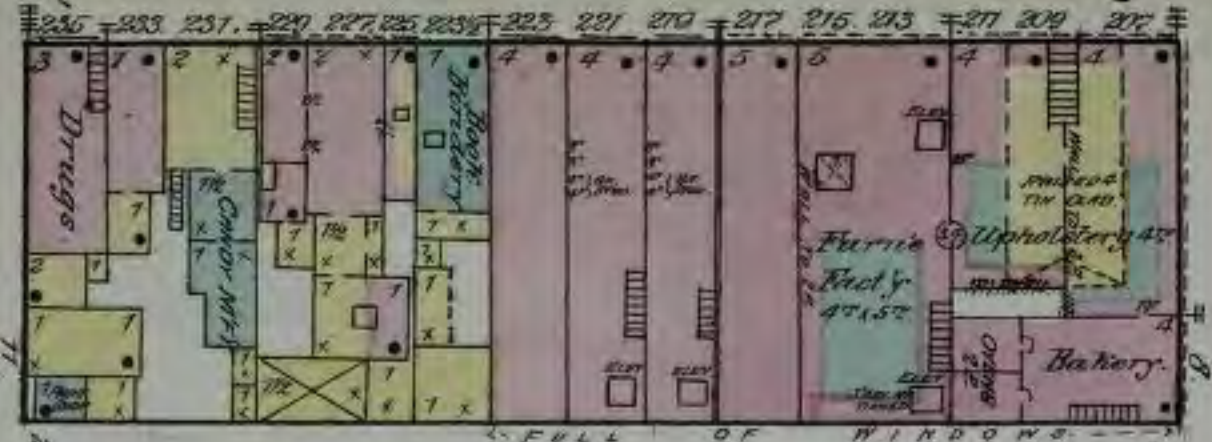

3

CLIFFORD

CRISWOLD

AVENUE

ROWLAND

HIGH SCHOOL.

WASHINGTON

1258 (50) WASHINGTON

ST. ALOYSIUS CATHOLIC CHURCH.

E. PARK

RIVER

GRAND

CHURCH OF CHRIST.

AVENUE

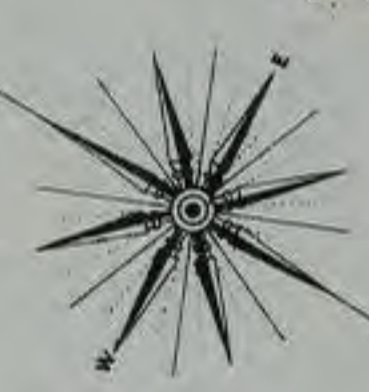

MACOMB

W. PARK

PLACE

PARK

PLACE

STATE

H. WILLIAMS RIDING SCHOOL.

DRY BLOCK.

AVE.

Scale of Feet.

CASS



1258 WASHINGTON



2

GRAND RIVER AV.

CAPITOL SQUARE PARK

ROWLAND

GRISWOLD

SEE

VOLUME

THREE

WOODWARD AV.

GRATIOT AV.

SEE VOL. FOUR

STATE

STATE

MICHIGAN AV.

VOLUME

WHITNEY'S OPERA HOUSE BLOCK

UNDER WHITNEY'S AUTOMATIC SPRINKLERS, WET SYSTEM. ONE SUPPLY SYSTEM SUPPLIED BY ONE 2.500 GALLON CAP. PRESSURE TANK AND ONE 2000 GALLON CAP. CHIEF'S TANK. 200 SPRINKLER HEADS COVERING AREA OF 100,000 SQ. FT. EACH. NO SPRINKLERS UNDER BALCONIES. NO OUTSIDE STEAMER LINK TO SYSTEM.

Scale of Map: 50 Feet to one inch

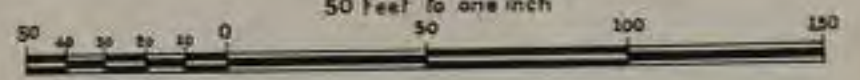

ONE

MAJESTIC BUILDING

2-12 MICHIGAN AV. BLOCK  
FIRE PROOF CONSTRUCTION  
2ND TO 8TH FLOOR INCL. OCCUPIED BY MABLEY & GUNDELSON CO'S. DEPARTMENT STORE. OFFICES ABOVE 8TH FLOOR. 3000 GALLON TANK IN ATTIC, CONNECTED TO STAND PIPE. 2 STANDARD DUPLEX PUMPS SIZE 125 G.P.M. 100 P.S.I. 4 3/4\"/>





1258 WASHINGTON

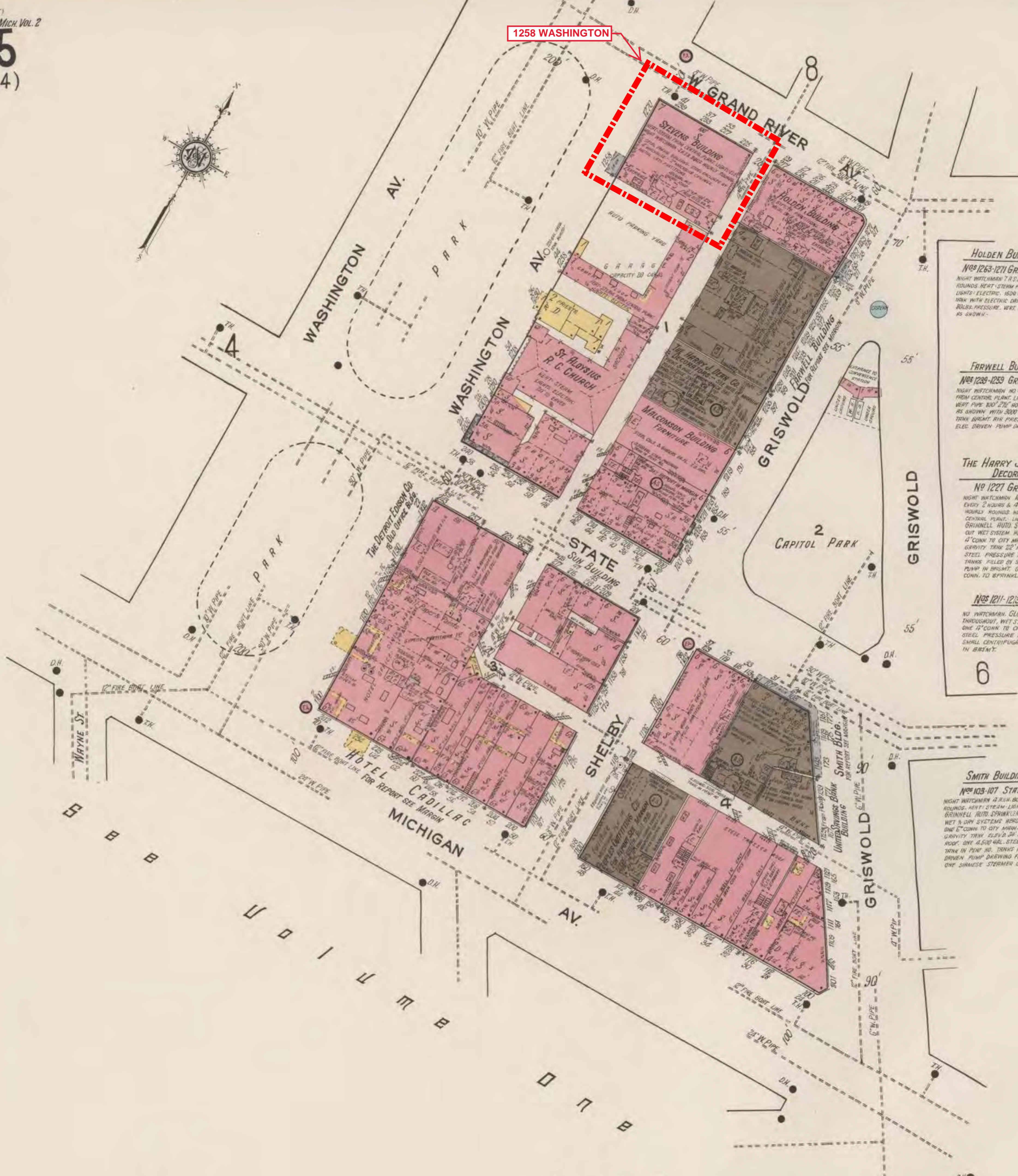

**HOLDEN BUILDING**

Nos 1263-1271 Griswold St.  
NIGHT WATCHMAN 7 H.S.R. BOLES, HOURLY ROUNDS. HEAT - STEAM FROM CENTRAL PLANT. LIGHTS - ELECTRIC. 1500 GAL. STEEL PRESSURE TANK WITH ELECTRIC DRIVEN PUMP BASMT. RISERS. PRESSURE, VERT. PIPE WITH HOLES AS SHOWN.

**FARWELL BUILDING**

Nos 1238-1239 Griswold St.  
NIGHT WATCHMAN NO CLOCK - NO STEAM FROM CENTRAL PLANT. LIGHTS - ELECTRIC. VERT. PIPE 2 1/2" HOSE ATT'D EACH FL. AS SHOWN WITH 3000 GAL. STEEL PRESSURE TANK BASMT. RISK PRESSURE 85 LBS. ELEC. DRIVEN PUMP DRAWING FROM CITY MAIN.

**THE HARRY J. DEAN CO. DECORATORS**

No 1227 Griswold St.  
NIGHT WATCHMAN 18 H.S.R. BOLES, HOURLY ROUNDS. HEAT - STEAM FROM CENTRAL PLANT. LIGHTS - ELECTRIC - GRINNELL AUTO SPRINKLERS THROUGHOUT WET SYSTEM. HEADS SPACED 8' X 4" CONN. TO CITY MAIN. ONE 15,000 GAL. GRAVITY TANK 22' DIA. AND 1500 GAL. STEEL PRESSURE TANK IN PENT. NO. TANKS FILLED BY SMALL ELEC. DRIVEN PUMP IN BASMT. ONE SIAMSE STR. CONN. TO SPRINKLERS.

**Nos 1211-1213 Griswold St.**

NO WATCHMAN. GLOBE AUTO SPRINKLERS THROUGHOUT, WET SYSTEM. HEADS SPACED 8' X 4" CONN. TO CITY MAIN. ONE 15,000 GAL. STEEL PRESSURE TANK IN PENT. NO. WITH SMALL CENTRIFUGAL PUMP & AIR COMP. IN BASMT.

**SMITH BUILDING**

Nos 103-107 State St.  
NIGHT WATCHMAN 2 H.S.R. BOLES HOURLY ROUNDS. HEAT - STEAM - LIGHTS - ELECTRIC - GRINNELL AUTO SPRINKLERS THROUGHOUT WET N-DRY SYSTEM. HEADS SPACED 10' X 10" CONN. TO CITY MAIN. 25,000 GAL. GRAVITY TANK 25' DIA. 5' ABOVE MAIN FLOOR. ONE 1500 GAL. STEEL PRESSURE TANK IN PENT. NO. TANKS FILLED BY ELEC. DRIVEN PUMP DRAWING FROM CITY MAIN. ONE SIAMSE STERNER CONNECTION.

**HOTEL CADILLAC**

No 200-228 Michigan Av.  
NIGHT WATCHMAN REPORTING TO 11 H.S.R. BOLES & TO 6 MICHIGAN BLDG. H.S.R. BOLES HOURLY ROUNDS. HEAT - STEAM FROM CENTRAL PLANT (OWN BOILERS NOT USED). LIGHTS - ELECTRIC - POWER - STEAM & ELEC. 2" VENT. PIPE WITH 30' 1 1/2" HOSE ATT'D EACH FLOOR. SUPPLY BY 7000 GAL. WATER TANK ON ROOF AND BY TWO CENTRIFUGAL FIRE PUMPS CAPACITY 100 GALS. PER MIN. EACH DRAWING FROM CITY MAIN. BARBOCK & PYRE'S CHEM. EXTING. DISTRIBUTED.

**PEOPLES OUTFITTING Co. FURNITURE, CARPETS & RUGS.**

No 150 Michigan Av.  
NIGHT WATCHMAN 3 H.S.R. BOLES, HOURLY ROUNDS. HEAT - STEAM FROM CENTRAL PLANT. POWER & LIGHTS - ELECTRIC - INTERNATIONAL AUTO SPRINKLERS THROUGHOUT. WET SYSTEM HEADS SPACED 8' X 10'. ONE 8" CONN. TO CITY MAIN. ONE 6000 GAL. STEEL PRESSURE TANK UNDER ROOF. ONE 1500 GAL. CENTRIFUGAL FIRE PUMP CAPACITY 500 GALS. PER MIN. TWO SIAMSE STERNER COANS. I. D. T. SUPERVISORY SERVICE TO SPRINKLERS. 4" V.P. 2 1/2" HOSE ATT'D EACH FLOOR AS SHOWN.

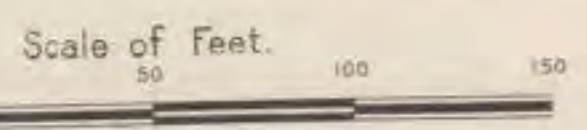

Copyright 1910 by the Sanborn Map Co.





1258 WASHINGTON



SCALE 50 FT TO ONE INCH



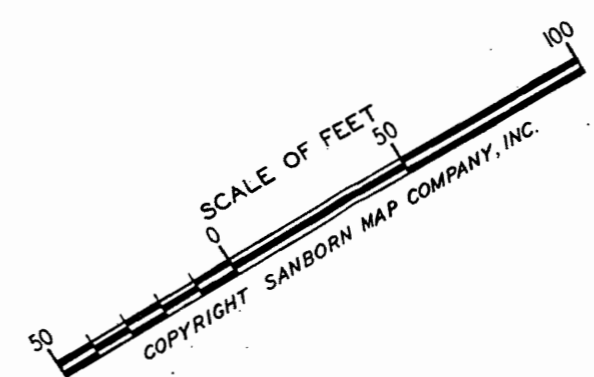
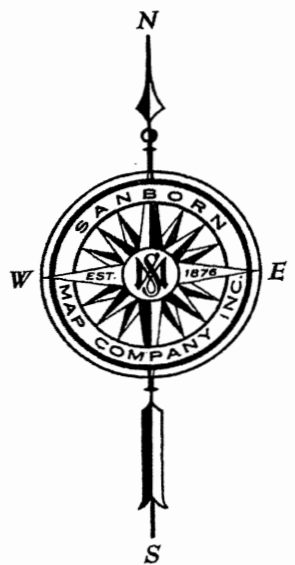
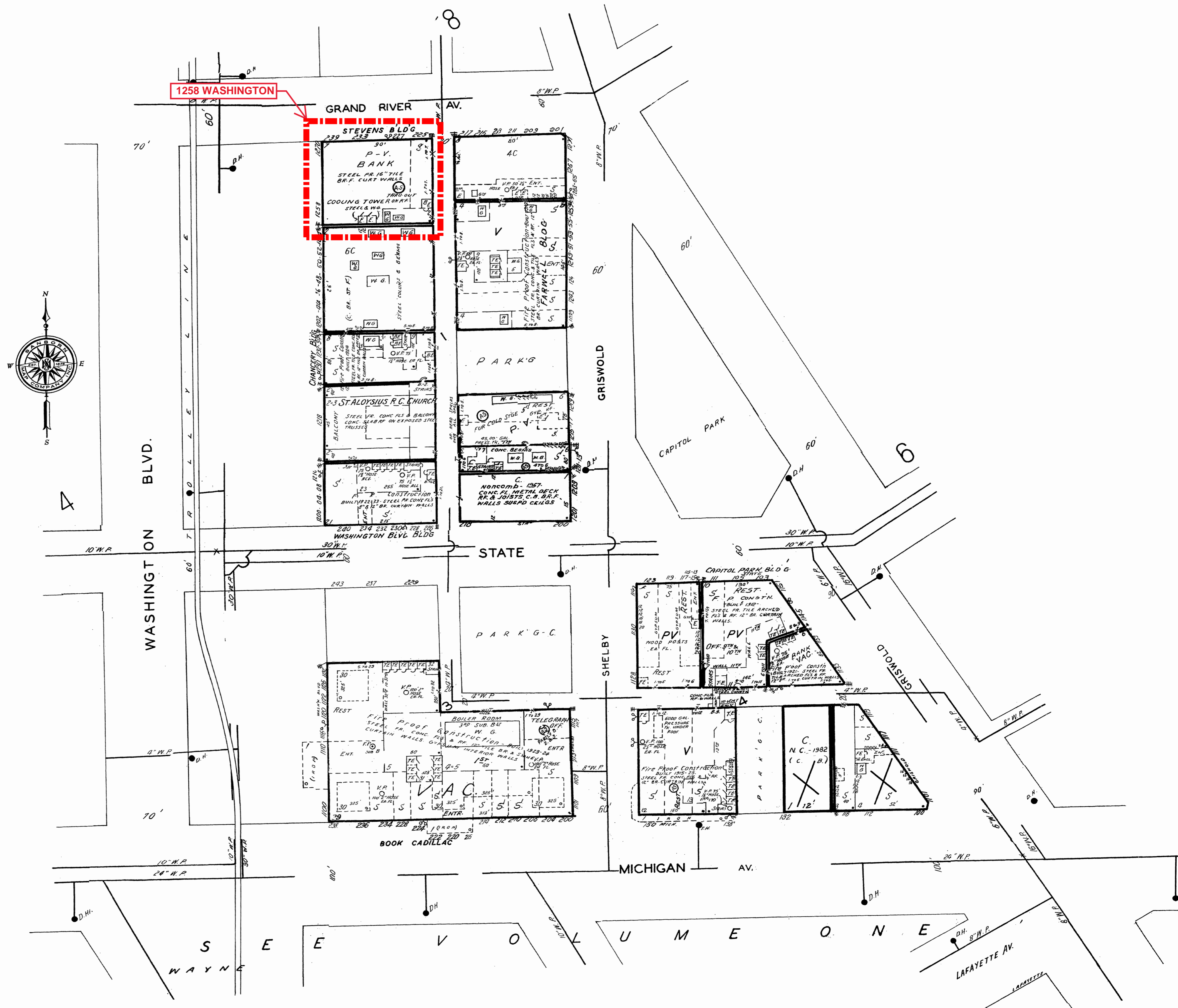





rs Jr Blvd  
on Blvd

ONE WAY  
←

DO NOT  
ENTER

Showroom/Warehouse  
**EXTREME**  
GRANITE & MARBLE  
GRANITE | MARBLE | QUARTZ | QUARTZITE  
248-307-0832  
Troy, MI

**STAFF SITE VISIT 08/04/2020**





Grand River

Washington Blvd

EXTREME  
GRANITE & MARBLE  
248-307-0832

STAFF SITE VISIT 08/04/2020





**STAFF SITE VISIT 08/04/2020**





**STAFF SITE VISIT 08/04/2020**





**STAFF SITE VISIT 08/04/2020**





STAFF SITE VISIT 08/04/2020



# HISTORIC DISTRICT COMMISSION PROJECT REVIEW REQUEST

CITY OF DETROIT  
PLANNING & DEVELOPMENT DEPARTMENT  
2 WOODWARD AVENUE, ROOM 808, DETROIT, MI 48226

DATE: 7-21-2020

## PROPERTY INFORMATION

ADDRESS: 1258 Washington Blvd AKA: 1260 Washington Blvd

HISTORIC DISTRICT: Washington Boulevard Historic District

## APPLICANT IDENTIFICATION

Property Owner/Homeowner       Contractor       Tenant or Business Occupant       Architect/Engineer/Consultant

NAME: James Flora COMPANY NAME: Beer Exchange, LLC

ADDRESS: 211 East Water Street CITY: Kalamazoo STATE: MI ZIP: 49007

PHONE: (269) 532-1188 MOBILE: (248) 207-6069 EMAIL: jflora@kalamazoobeerexchange.com

## PROJECT REVIEW REQUEST CHECKLIST

Please attach the following documentation to your request:

**Photographs** of ALL sides of existing building or site

**Detailed photographs** of location of proposed work (photographs to show existing condition(s), design, color, & material)

**Description of existing conditions** (including materials and design)

**Description of project** (if replacing any existing material(s), include an explanation as to why replacement--rather than repair--of existing and/or construction of new is required)

**Detailed scope of work** (formatted as bulleted list)

**Brochure/cut sheets** for proposed replacement material(s) and/or product(s), as applicable

### NOTE:

Based on the scope of work, additional documentation may be required.

See [www.detroitmi.gov/hdc](http://www.detroitmi.gov/hdc) for scope-specific requirements.

Upon receipt of this documentation, staff will review and inform you of the next steps toward obtaining your building permit from the Buildings, Safety Engineering and Environmental Department (BSEED) to perform the work.

**SUBMIT COMPLETED REQUESTS TO [HDC@DETROITMI.GOV](mailto:HDC@DETROITMI.GOV)**



LEONARD ELSE DESIGN ASSOCIATES INC.

2760 DIXIE HIGHWAY, WATERFORD, MICHIGAN, MI 48328-1711  
VOICE (248) 673-5730 FAX (248) 673-6480

JULY 27, 2020

**SCOPE OF WORK**

**Y1801 – Beer Exchange Detroit  
HDC Review 4 (Internally Lite Blade Sign)**

- The following Scope of Work applies to the Detroit Beer Exchange as shown on the HDC Project Review Request form dated 7-21-2020.
- The proposed work is part of a new restaurant within the basement and first level of the existing Stevens Building on 1258 Washington Blvd.
- We propose installing an exterior blade sign (sign-c) on the North-West corner of the building. This sign will be internally illuminated, not externally illuminated. It will be attached to the existing building limestone panel façade. It will be made of acrylic faces with full color graphics.
- Sign-C is noted on our architectural drawings from the last HDC Review 3, dated 6-10-2020. Sign-C is also known as Blade Sign-A by Spectrum.
- Existing building conditions along with new sign, color and materials are noted on drawing and photos from the signage contractor, Spectrum Neon Signage. For added job description by the sign contractor refer Spectrum letter dated 7-27-2020.

**Leonard Else Design Associates**

leonardelsedesign@att.net



07.27.2020

To: Detroit Historic District Commission

Re: Detroit Beer Exchange / Exterior Signage / Project description

Attn: Ann Phillips, AIA

The work being sought for approval consists of an internally illuminated projecting sign approx. 60" in dia. And having acrylic faces with full color vinyl overlay (Beer Exchange logo). To be mounted to existing limestone façade.

The sign would be mounted at a 45 degree angle at the corner of Washington Blvd. & Grand River.

Thank you,

Kerry Kulas

Sales Associate





**DETROIT BEER EXCHANGE  
WASHINGTON ELEVATION**



**DETROIT BEER EXCHANGE  
GRAND RIVER ELEVATION**





**DETROIT BEER EXCHANGE  
ALLEY ELEVATION**



**DETROIT BEER EXCHANGE  
ALLEY ELEVATION**



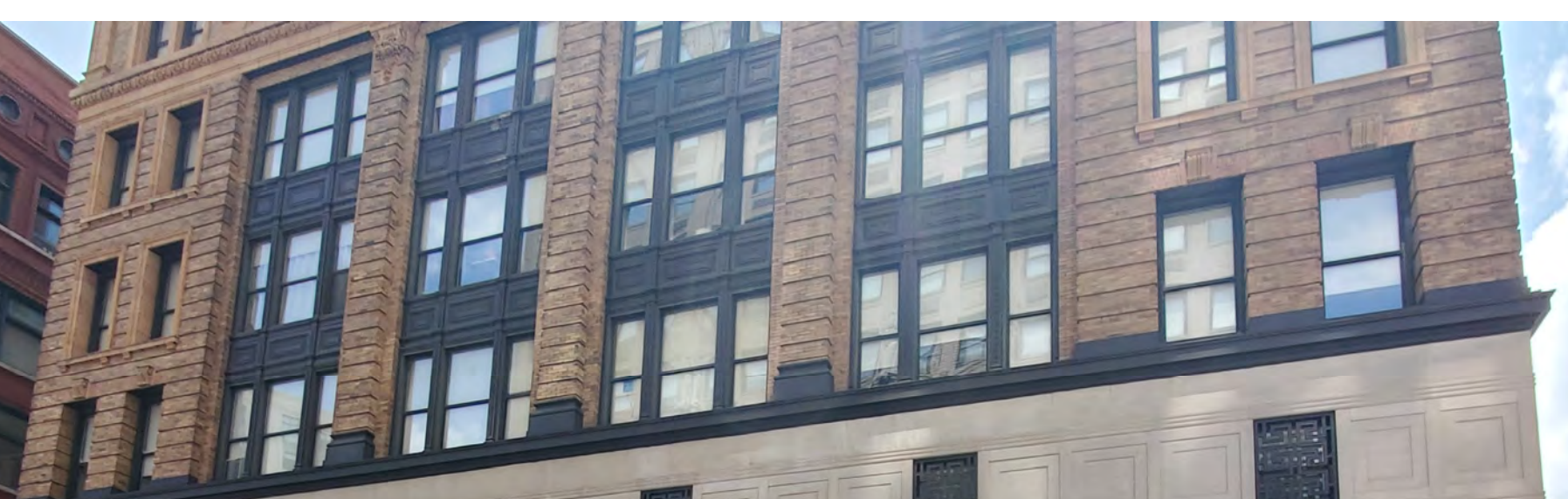



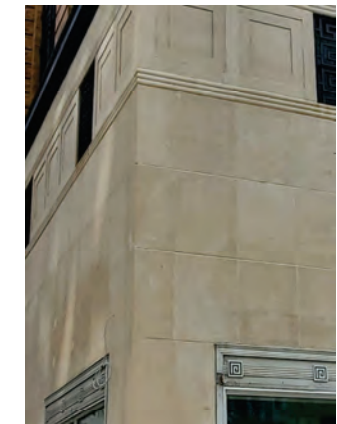









NORTH ELEVATION -  
(GRAND RIVER AVE)



WEST ELEVATION -  
(WASHINGTON BLVD.)



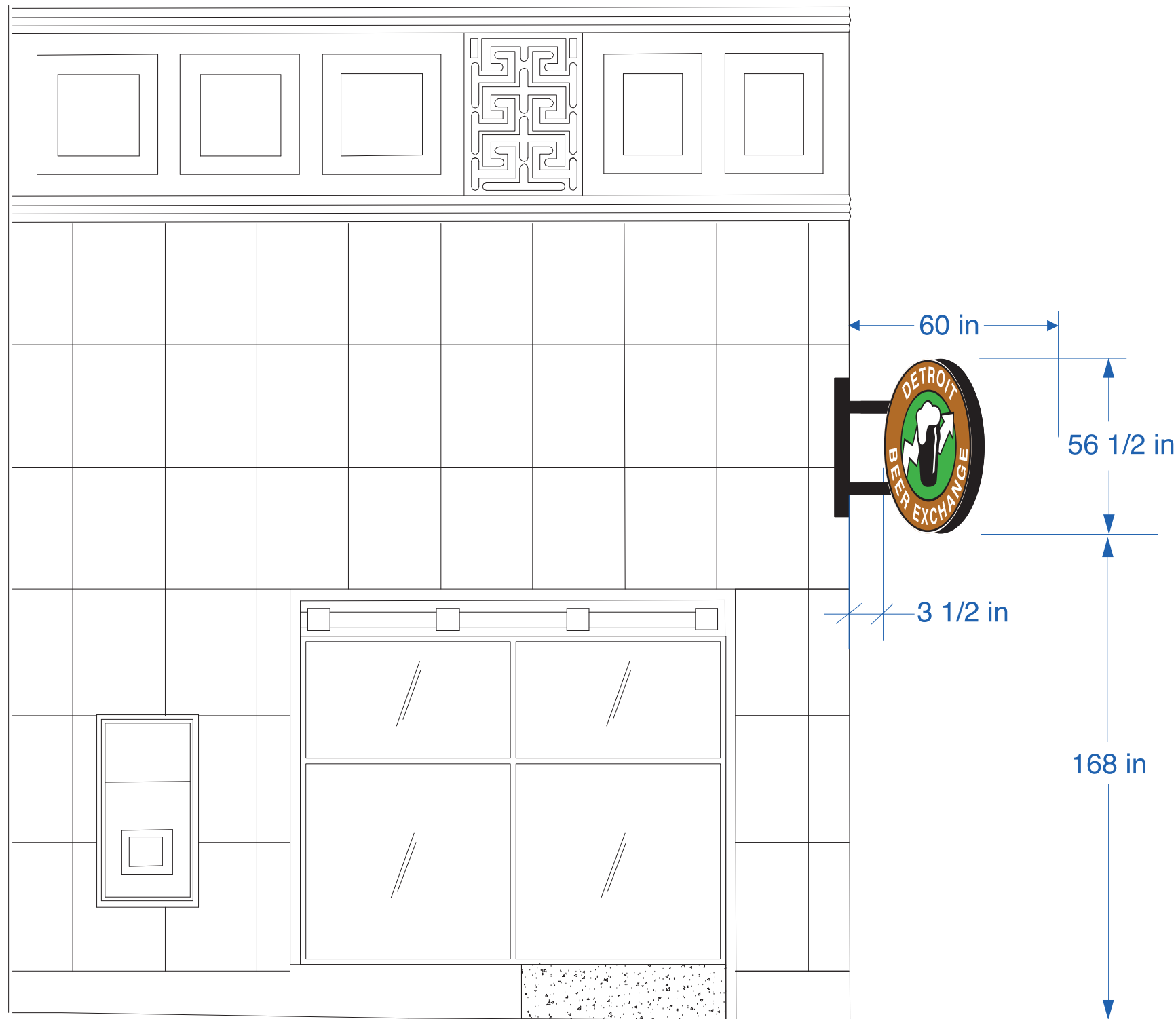

**BLADE SIGN A**

## **INTERNALLY ILLUMINATED / PROJECTION SIGN**

File Name: INTERNALLY ILLUMINATED BLADE SIGN	Date: 07.02.2020	Drawn by:
Customer: DETROIT BEER EXCHANGE	This drawing is the property of SPECTRUM NEON CO. DETROIT, MI. And is submitted in connection with the transaction to which it pertains and is not to be traced or copied. It must not be used in any manner detrimental to our interests and must be returned upon request.	Checked by:
Location: 1258 WASHINGTON BLVD.		



**SPECTRUM NEON CO.**  
 SIGNS • LIGHTING  
 3750 E. OUTER DR.  
 DETROIT, MI. 48234.  
 P. 313 366 7333  
 F. 313 366 8328

[WWW.SPECTRUMNEON.COM](http://WWW.SPECTRUMNEON.COM)



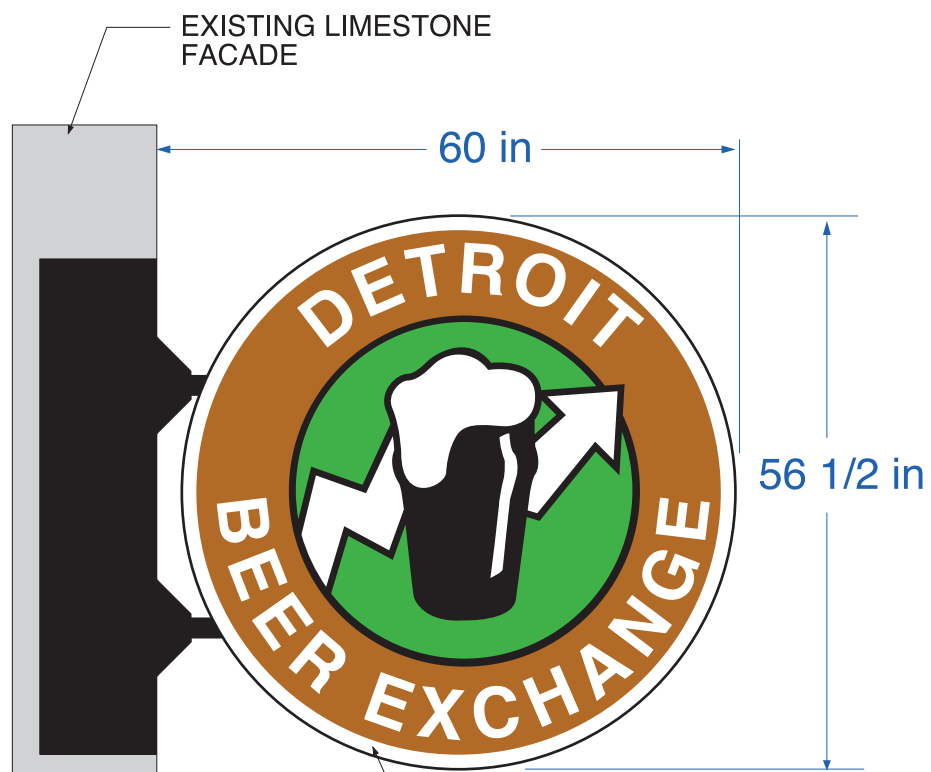

3/16" ACRYLIC FACES WITH FULL COLOR GRAPHICS INTERNALLY ILLUMINATED

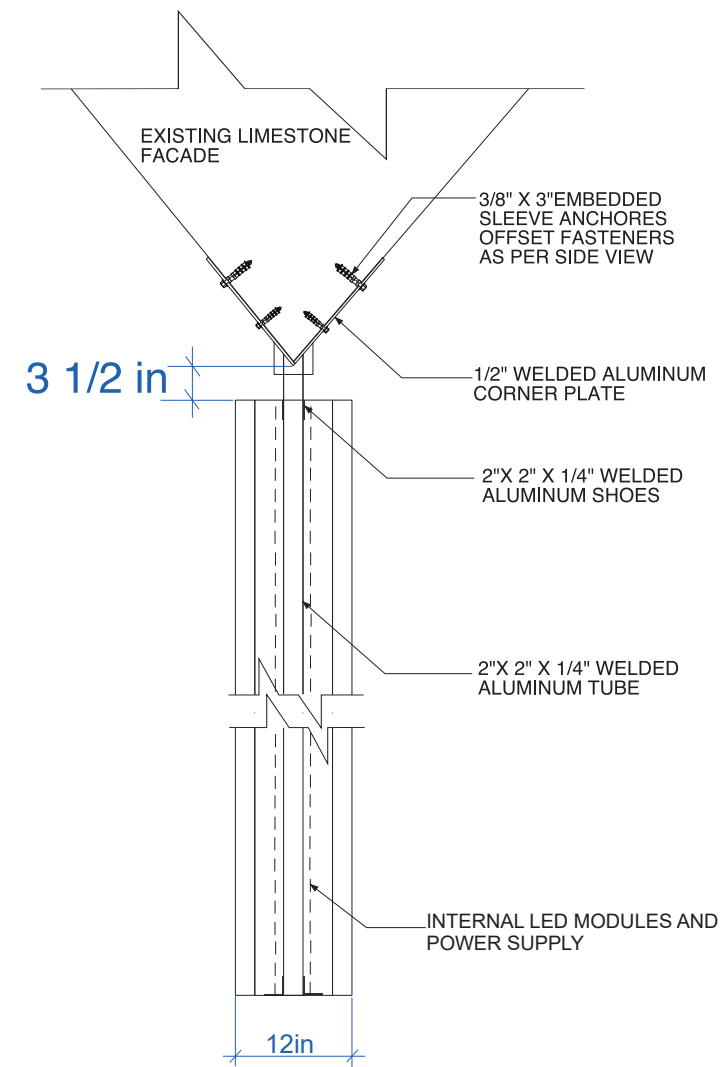
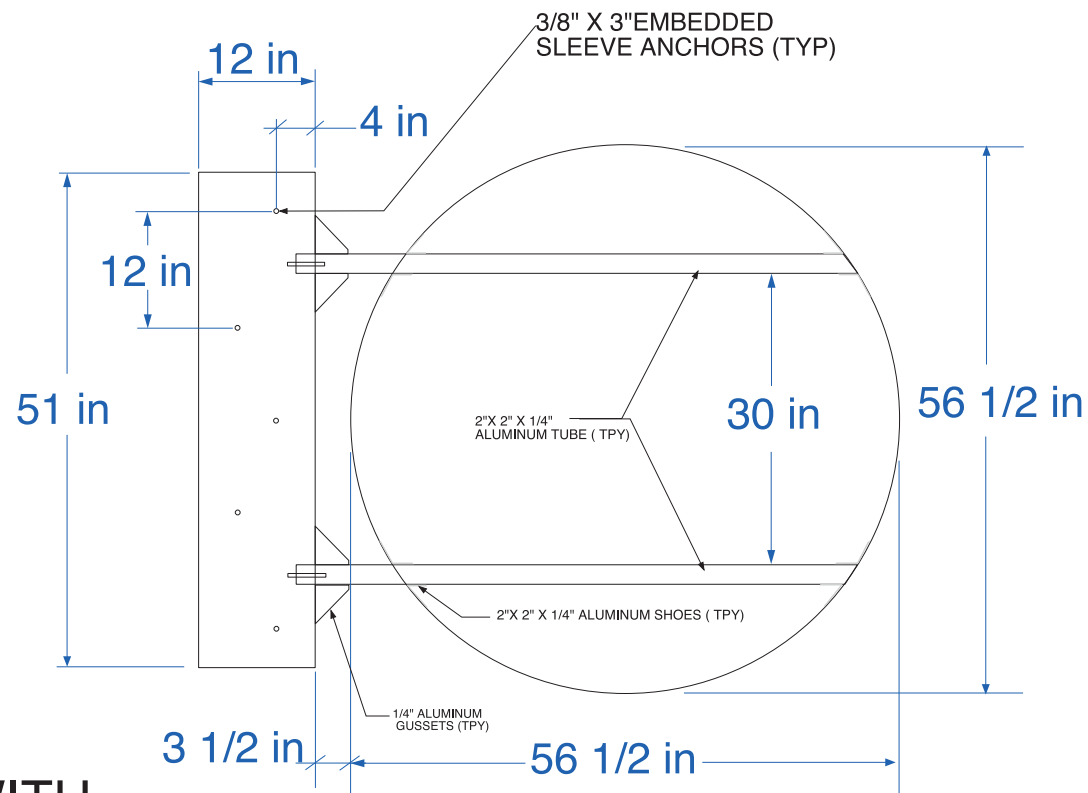

TOP VIEW

17.41 SQ. FT.

- PANTON 1675 ORANGE
- PANTON 369 GREEN

BLADE SIGN A

## INTERNALLY ILLUMINATED / PROJECTION SIGN

File Name: INTERNALLY ILLUMINATED BLADE SIGN	Date: 07.02.2020	Drawn by: KPK	 <b>SPECTRUM NEON CO.</b> SIGNS • LIGHTING 3750 E. OUTER DR. DETROIT, MI. 48234. P. 313 366 7333 F. 313 366 8328 <a href="http://WWW.SPECTRUMNEON.COM">WWW.SPECTRUMNEON.COM</a>
Customer: DETROIT BEER EXCHANGE	This drawing is the property of SPECTRUM NEON CO. DETROIT, MI. And is submitted in connection with the transaction to which it pertains and is not to be traced or copied. It must not be used in any manner detrimental to our interests and must be returned upon request.		
Location: 1258 WASHINGTON BLVD.	Checked by:		







Y1801  
EXISTING INTERNALLY  
ILLUMINATED SIGN -  
"ROAST" FACING  
WASHINGTON BLVD.  
7-29-2020





Y1801  
EXISTING INTERNALLY  
ILLUMINATED SIGN -  
"STARBUCK" FACING  
CORNER OF  
WASHGINGTON BLVD  
& MICHIGAN AVE.  
7-29-2020

