

2/14/23

NOTICE OF DENIAL

Kevin Brandon
BmK Design + Planning, LLC
54048 Mound Rd.
Shelby Township, MI 48316

RE: Application Number 23-8201; 761 Whitmore; Palmer Park Apartment Buildings Historic District

Dear Applicant,

At the Regular Meeting that was held on February 8, 2023, the Detroit Historic District Commission (“DHDC”) reviewed the above-referenced application. Pursuant to Section 5(1) and 9(1) of the Michigan Local Historic District Act, as amended, being MCL 399.205 (1), MCL 399.209 (9) and Sections 21-2-78 and 21-2-80 of the 2019 Detroit City Code; the DHDC hereby issues a Denial for the following work, effective on February 14, 2023, as it will be inappropriate according to the Secretary of Interior’s Standards for Rehabilitation and the district’s Elements of Design:

- ***The replacement of the original wood windows and wood brick moulds with vinyl windows and aluminum brick moulds***

The Commission's reason for denial is that the proposed work will destroy architectural features that characterize the property.

- The windows that were removed without approval were a distinct historic feature that characterized the property.
- Vinyl material is not an appropriate material for the Palmer Park Apartment Buildings Historic District or this particular property.
- The introduction of between the glass muntins, which replaced the true divided light of the original wood windows, is not an adequate match for the original true divided lite of the original windows.
- The current large aluminum brick moulds create a blocky appearance that destroys the refined dimensions and craftsmanship of the original wood brick moulds.

Therefore, this work fails to meet the Secretary of the Interior’s Standards, specifically Standards:

- 2) ***The historic character of a property shall be retained and preserved. The removal of historic materials or alteration of features and spaces that characterize a property shall be avoided.***
- 5) ***Distinctive features, finishes, and construction techniques or examples of craftsmanship that characterize a historic property shall be preserved.***
- 6) ***Deteriorated historic features shall be repaired rather than replaced. Where the severity of deterioration requires replacement of a distinctive feature, the new feature shall match the old in design, color, texture, and other visual qualities and, where possible, materials. Replacement of missing features shall be substantiated by documentary, physical, or pictorial evidence.***

The application may be resubmitted for the Historic District Commission's review when suggested changes have been made that address the cited reasons for denial, if applicable. Please be advised that, in accordance with MCL 399.211 and Section 21-2-81 of the 2019 Detroit City Code, an applicant aggrieved by a decision of the DHDC may file an appeal with the State Historic Preservation Review Board. Within sixty (60) days of your receipt of this notice, an appeal may be filed with:

Jon Stuckey, Michigan Department of Attorney General
2nd Floor, G. Mennen Williams Building
525 West Ottawa Street, P.O. Box 30754, Lansing, MI 48909
Phone: 517-335-0665 E-mail: stuckeyj@michigan.gov

If you have any questions regarding the foregoing, please contact staff at 313-224-1762 or hdc@detroitmi.gov.
For the Commission:



Daniel Rieden, Detroit Historic District Commission

DHDC 23-8201

APPROVAL DOCUMENT – POST AT WORK LOCATION

CITY OF DETROIT
HISTORIC DISTRICT COMMISSION

2 WOODWARD, SUITE 808
DETROIT, MICHIGAN 48226

2/14/23

CERTIFICATE OF APPROPRIATENESS

Kevin Brandon
BmK Design + Planning, LLC
54048 Mound Rd.
Shelby Township, MI 48316

RE: Application Number 23-8201; 761 Whitmore; Palmer Park Apartment Buildings Historic District

Dear Applicant,

At the Regular Meeting that was held on February 8, 2023, the Detroit Historic District Commission (“DHDC”) reviewed the above-referenced application. Pursuant to Section 5(1) of the Michigan Local Historic District Act, as amended, being MCL 399.205 (1) and Sections 21-2-73/21-2-78 of the 2019 Detroit City Code; the DHDC hereby issues a Certificate of Appropriateness (“COA”) for the following work, effective on February 14, 2023, as it meets the Secretary of Interior’s Standards for Rehabilitation and the district’s Elements of Design:

- ***The installation of the proposed 14 doors and 4 doorways per the attached drawings and details, painted Sherwin Williams (SW7593) Rustic Red***

The Certificate of Appropriateness is issued with the following conditions:

- ***Applicant supplies HDC staff with modified design for the four front entrance doors’ window configurations for approval and before installation.***

Please retain this COA for your files and post it at the subject property until work is complete. It is important to note that approval by the DHDC does not waive the applicant's responsibility to comply with any other applicable ordinances or statutes. If you have any questions regarding the foregoing, please contact staff at 313-224-1762 or hdc@detroitmi.gov.

For the Commission:



Daniel Rieden
Detroit Historic District Commission



54048 Mound Road Shelby Township Michigan 48316

November 10, 2022

Historic District Commission Review
761 Whitmore
Rosemor Apartment Window Replacement

Description of Existing Conditions

The Rosemor Apartments building was constructed in 1948 and designed by Wiedmaier & Gay Architects. Wiedmaier & Gay, who had once designed many of the eclectic apartment buildings of the 1920s in Palmer Park, later designed Modernistic buildings including the Rosemor Apartments. It is a two and one-half story, hip roof, buff brick, irregular shaped, garden court apartment building. This thirty-unit apartment building is at the corner of Whitmore and Third and has one entrance that opens onto Whitmore (761 Whitmore Road) and two entrances that open onto the court (17450 and 17452 Third Avenue).

The building has received a Certificate of Appropriateness (COA 19-6423) on September 4, 2019 for brick and roof repair. This work was permitted, work completed, inspected, and approved by the building department.

New replacement windows were installed in the Summer of 2020 when the work noted above was being performed. The existing doors and entries were in poor condition and removed. Temporary doors were installed to secure the building.

Description of Project

With this current submittal, the applicant is seeking the board's approval for the installed windows and to complete following work associated with the overall rehabilitation of the building as per the attached drawings.

Detailed Scope of Work:

- Rebuild the four door entrances as shown on Sheet A700 provided with this submittal. The doors will be insulated hollow metal with three equally sized glass lites. The framing will be constructed of wood material. The color selected will be Sherwin Williams SW7593 Rustic Red. A color sample is provided in this submittal.
- The window as installed are double-hung, vinyl clad replacement windows. A window schedule with sizes and quantities are provide on Sheet A200 provided with this submittal.

Product Data

See attached brochure and cut sheet for additional information.

- Door and Frame Color, Sherwin Williams SW 7593-Rustic Red
- Windows: Manchester Series by Quaker, Color: Earthtone

Detailed Photographs of Existing Conditions



Photo 1: View looking southeast from Third Avenue



Photo 2: View looking northeast from Third Avenue



Photo 3: View looking southwest from Whitmore



Photo 4: View looking southwest from Whitmore

Door and Frame Color



SW 7593 – Rustic Red

761 Whitmore – HDC Supplemental Information

January 26, 2023

1. The doors are to be custom made. The photo below is of the front door at 931 Covington. This is the same exact door style that will be provided at 761 Whitmore. No doors are installed at this time.



Door at 931 Covington. Same style door to be used on 761 Whitmore.

2. The window muntins are between the glass panes. The glass is clear. The photo below shows muntin between the glass.



3. The original brick moulds were removed. New aluminum brick moulds were installed. The photo above shows the installation of the aluminum brick mould. Unfortunately, I do not have photos of the windows before they were removed. I was not involved with the project at the time of this work.

- I only have two photos. One each of door 2 and door 4.



Door 4 – Existing prior to securing.



Door 2 – Existing prior to securing.

- 100% of the windows have been replaced. The windows that are currently boarded up were due to demolition. They were removed to provide openings to facilitate removal of interior removed material. This work was city approved. The windows were to remain removed to allow for bringing in construction material in the future (drywall, etc.).

6. The brick on-site is left over from the stabilization work that was completed, inspected and approved. This work was completed under COA 19-6423 and BLD2019-06541.
7. My apologies. The windows are constructed of a vinyl composite material.



Bmk DESIGN + PLANNING, LLC
 54048 Mound Road - Shelby Township - Michigan - 48316
 Ph 248.303.1446
 kmb@bmkdp.com

PROJECT:
 Window Replacement Alterations
 761 Whitmore Road
 Detroit, MI 48203

CLIENT:
 RCI-761 Whitmore, LLC
 10 E. Main Street
 Suite 201
 Bridgeport, CT 06608

HDC PROJECT REVIEW DESCRIPTION	DATE
	10/10/2022

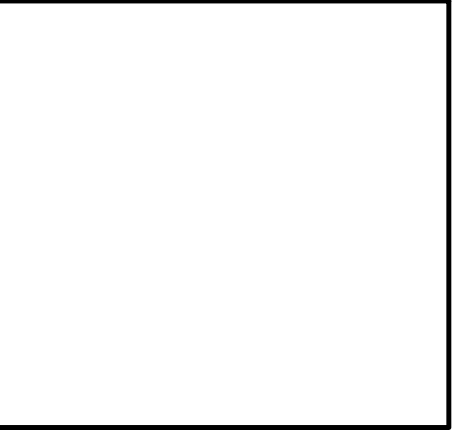

SHEET TITLE:
 OVERALL FOOTPRINT PLAN

PROJECT NUMBER:
 2020-122

DRAWN BY:
 --

CHECKED BY:
 --

SHEET NUMBER:
A100

Permit No.:

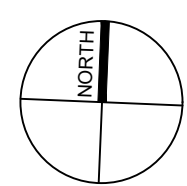
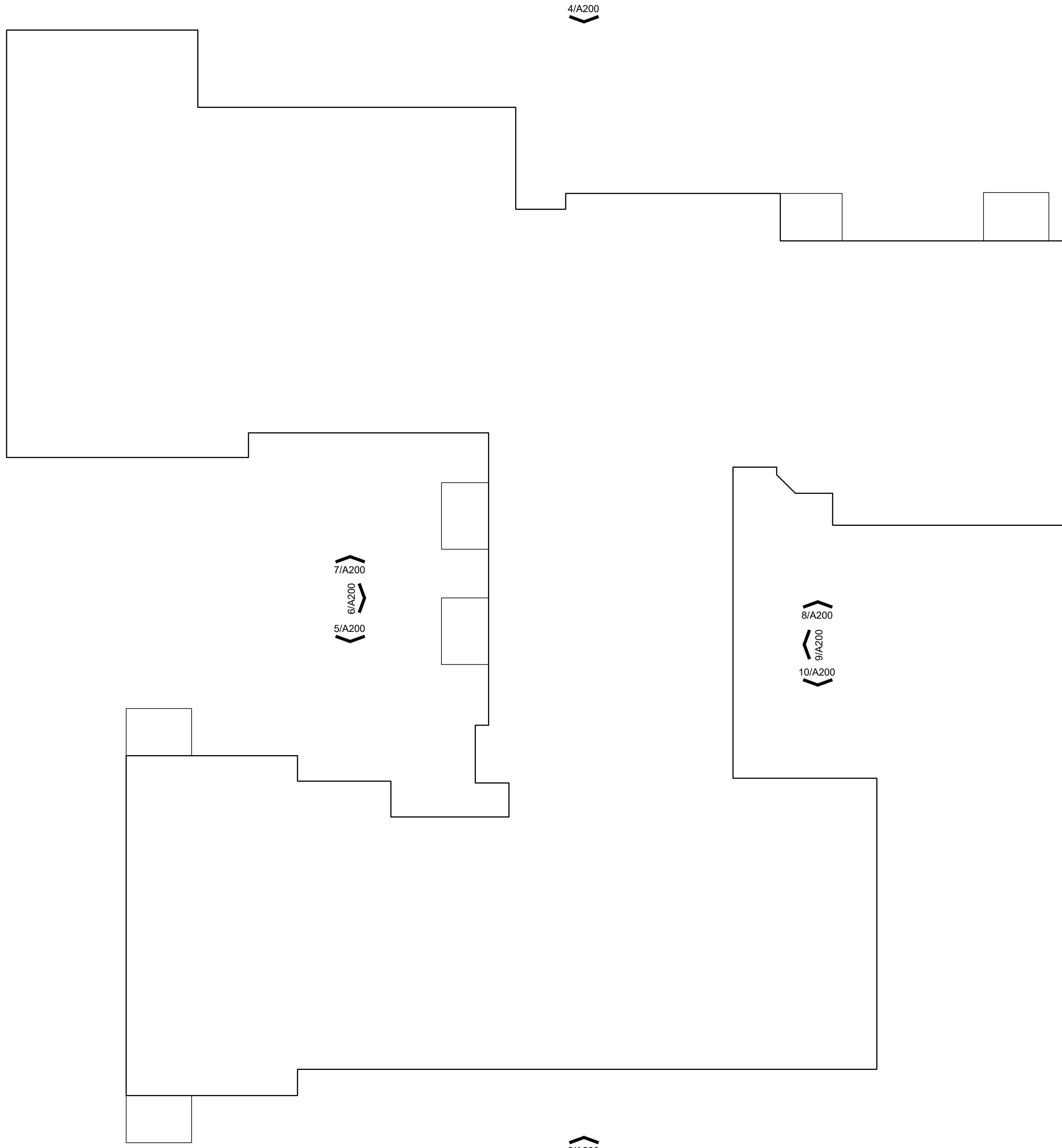

1/A100 overall footprint plan

HDC PROJECT REVIEW	10/10/2022
DESCRIPTION	DATE

SHEET TITLE:
EXTERIOR ELEVATIONS

PROJECT NUMBER:
2020-122

DRAWN BY:
--

CHECKED BY:
--

SHEET NUMBER:
A200

Permit No.:

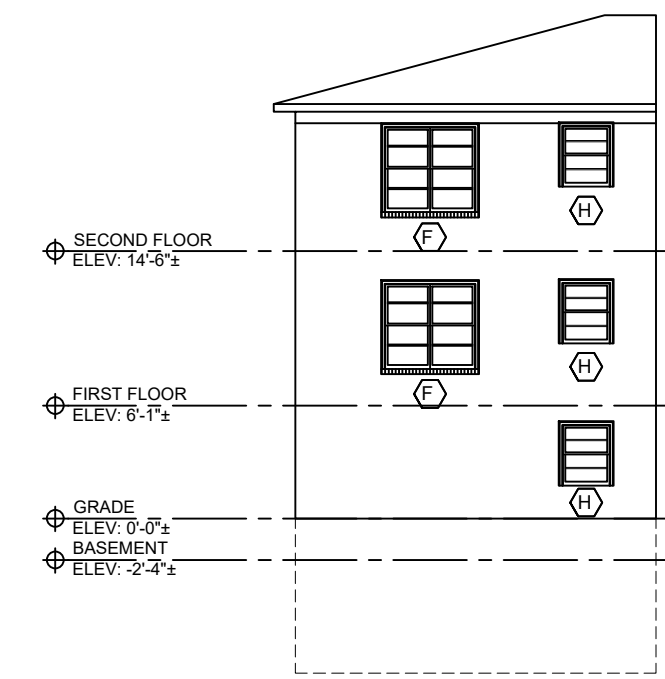

10/A200 south elevation at east courtyard
SCALE: 3/32" = 1'-0"

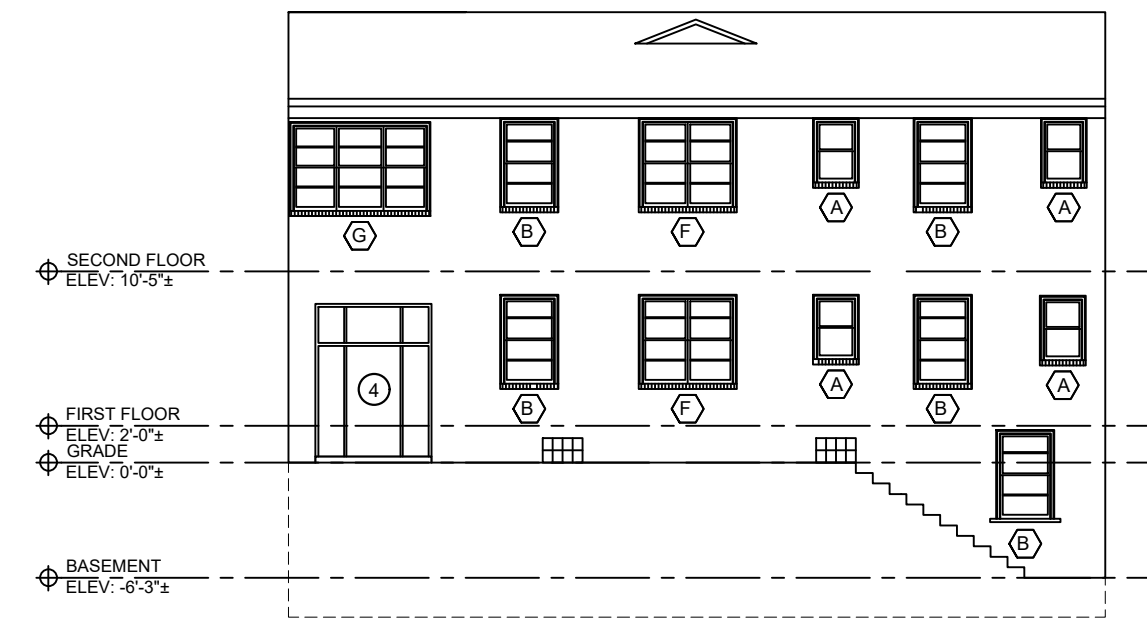

9/A200 west elevation at east courtyard



8/A200 north elevation at east courtyard

window schedule

TAG	QTY	NOM. WINDOW SIZE	TYPE
A	30	2'-6" x 3'-6"	DOUBLE HUNG
B	72	3'-0" x 5'-0"	DOUBLE HUNG
C	18	7'-6" x 5'-0"	(2) DOUBLE HUNG
D	12	9'-0" x 5'-0"	(3) DOUBLE HUNG
E	15	6'-0" x 5'-0"	(2) DOUBLE HUNG
F	25	5'-6" x 5'-0"	(2) DOUBLE HUNG
G	1	8'-0" x 5'-0"	(3) DOUBLE HUNG
H	6	3'-0" x 3'-6"	DOUBLE HUNG

ALL UNITS ARE LOW-E, DOUBLE PANE



7/A200 north elevation at west courtyard
SCALE: 3/32" = 1'-0"

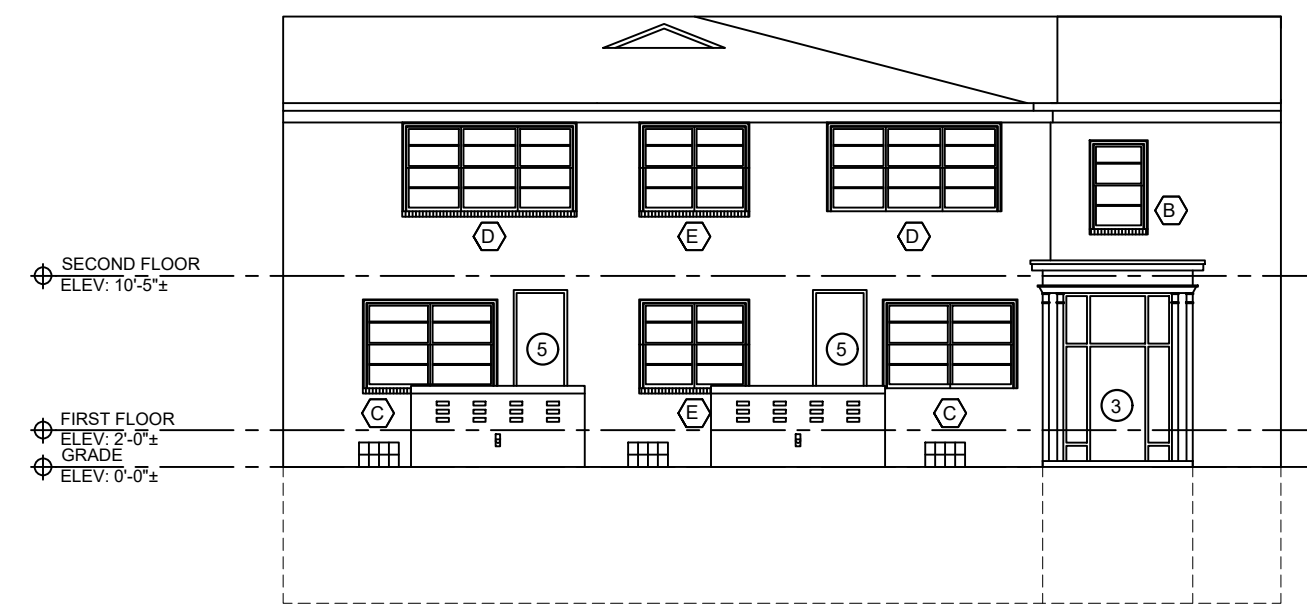

6/A200 east elevation at west courtyard
SCALE: 3/32" = 1'-0"

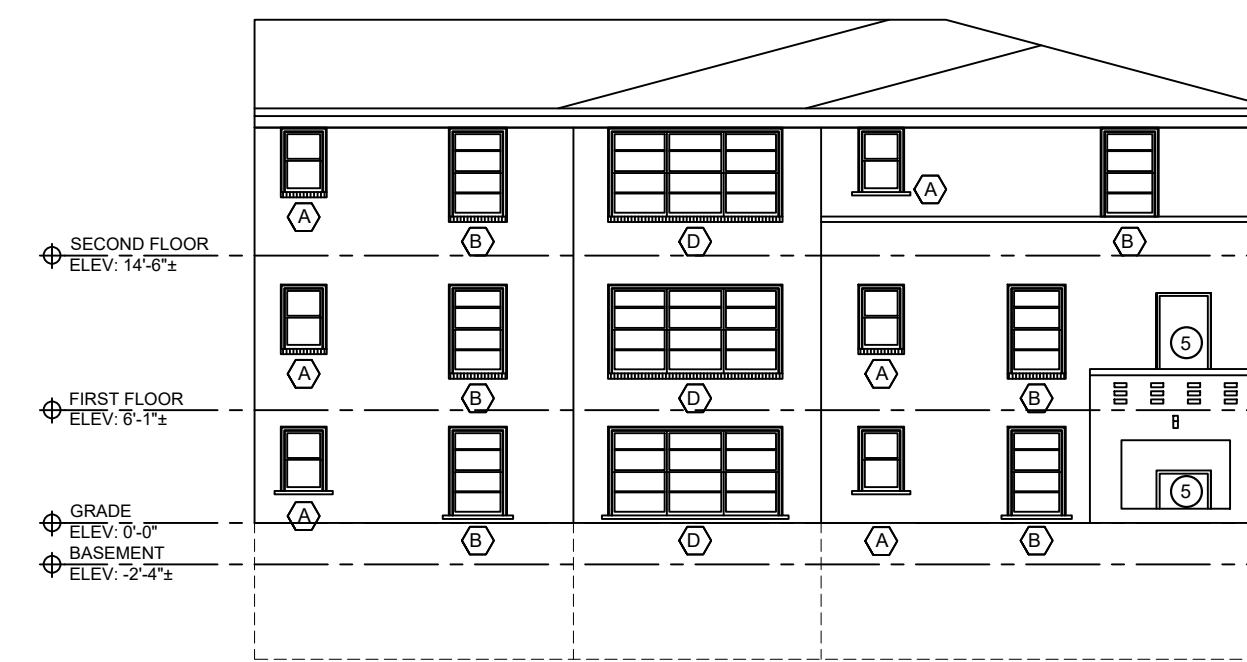

5/A200 south elevation at west courtyard
SCALE: 3/32" = 1'-0"

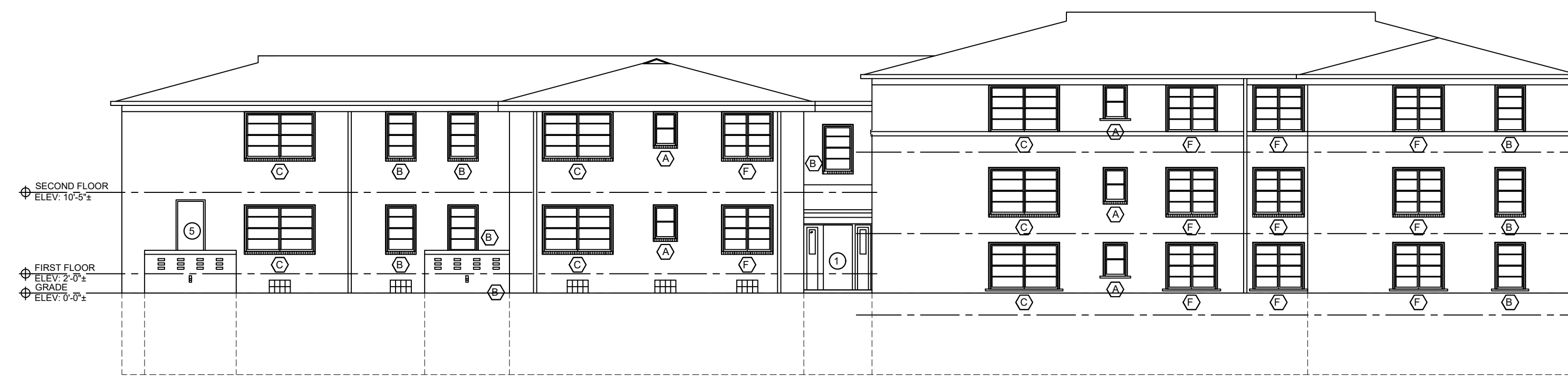

4/A200 north elevation
SCALE: 3/32" = 1'-0"



3/A200 east elevation
SCALE: 3/32" = 1'-0"

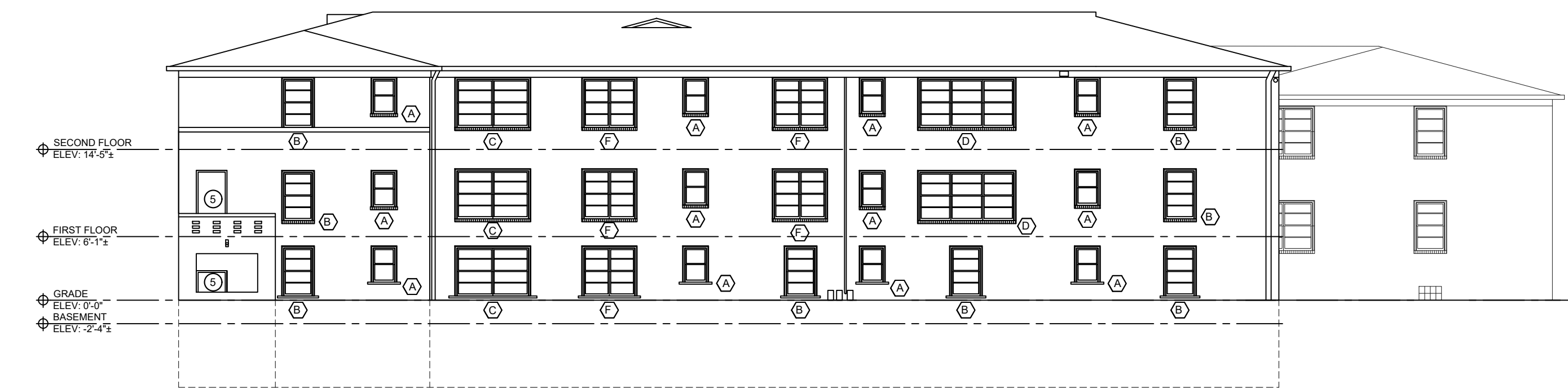

2/A200 south elevation
SCALE: 3/32" = 1'-0"



1/A200 west elevation
SCALE: 3/32" = 1'-0"



1

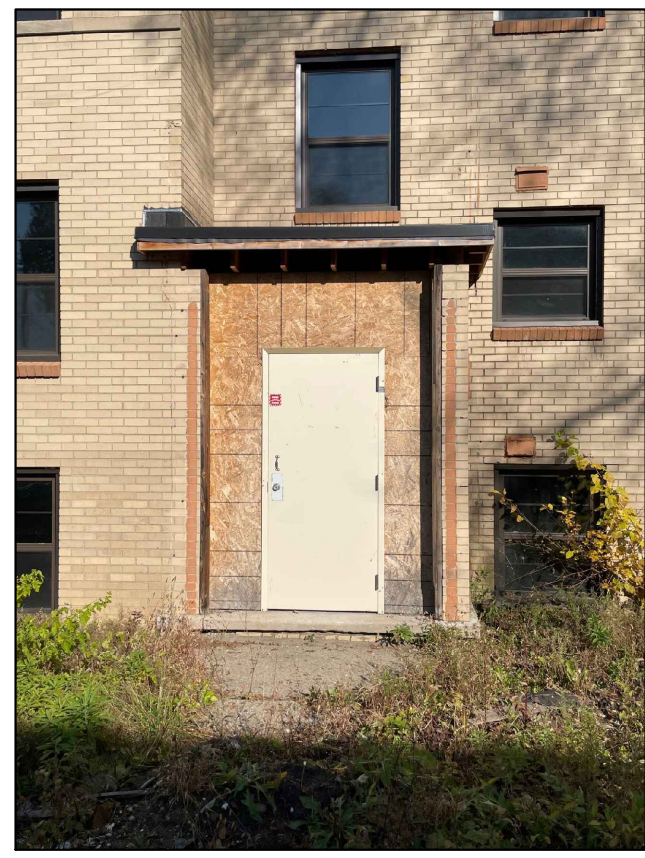

2



3



4



5



4/A700 photo of typical replacement window

3/A700 photos of existing conditions at entries

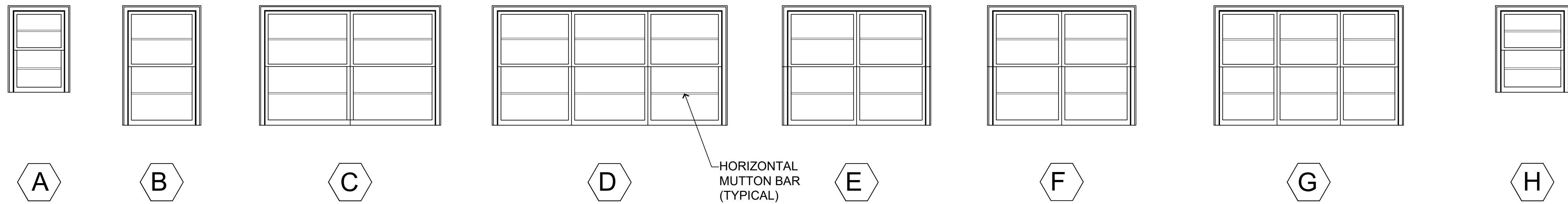

2/A700 window elevations

SCALE: 3/8" = 1'-0"

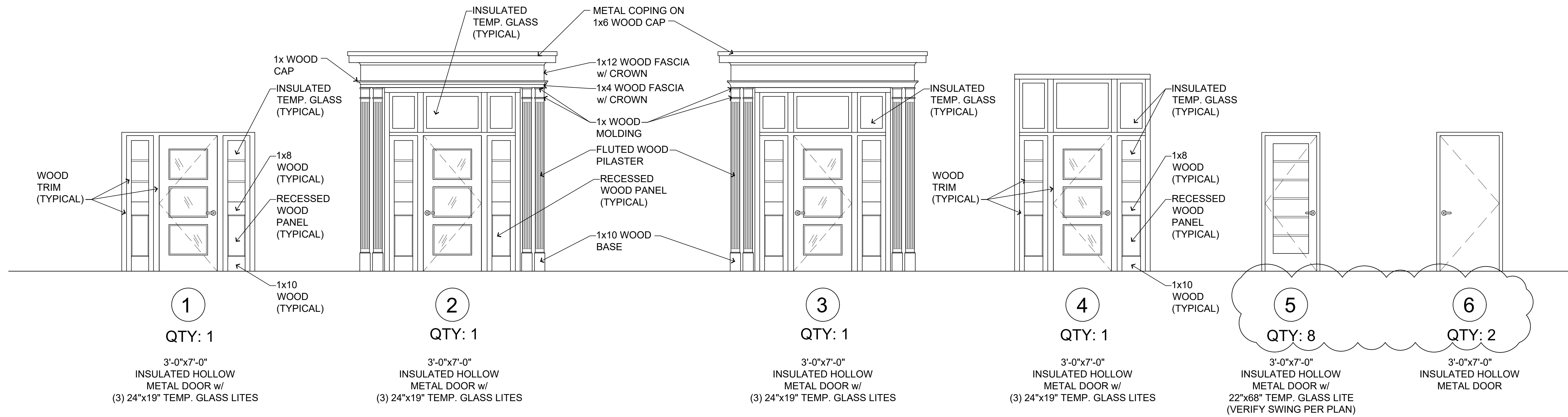

1/A700 door elevations

SCALE: 3/8" = 1'-0"

PROJECT:
Window Replacement Alterations
 761 Whitmore Road
 Detroit, MI 48203

CLIENT:
RCI-761 Whitmore, LLC
 10 E. Main Street
 Suite 201
 Bridgeport, CT 06608

HDC PROJECT REVIEW	10/10/2022
DESCRIPTION	DATE

SHEET TITLE:
DOOR & WINDOW ELEVATIONS

PROJECT NUMBER:
 2020-122

DRAWN BY:
 --

CHECKED BY:
 --

SHEET NUMBER:
A700

Permit No.:



QUAKER
COMMERCIAL WINDOWS AND DOORS

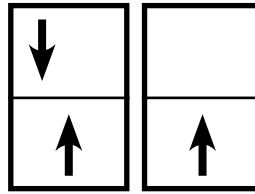

Manchester
SERIES

Manchester Series

R-40/R-35

3 1/4" Frame Depth

Double Hung/Single Hung

MANCHESTER SERIES DOUBLE HUNG/SINGLE HUNG

The Quaker Manchester Series Double Hung/Single Hung window is ideal for a variety of applications including - Energy Efficient, Apartments, Assisted Living and Housing Authority.

FEATURES

- ◇ **Commercial Framing System**
 - 3 1/4" main frame
 - 0.060" wall thickness of frame, 0.070" wall thickness of sash
- ◇ **Enhanced Design**
 - Mitered and welded corners
- ◇ **Glazing**
 - 3/4" insulated glass
- ◇ **Hardware**
 - Block and tackle balancers
- ◇ **Screen**
 - Roll form aluminum screen frame with BetterVue™ mesh

OPTIONS

- ◇ **Available Configurations**
 - Double Hung
 - Single Hung
 - Geometric shapes
- ◇ **Muntin Choices**
 - Internal or simulated divided lites available
- ◇ **Limited travel Hardware**
- ◇ **Nailing Fin**
- ◇ **Screen**
 - Roll form aluminum screen frame with aluminum wire mesh
 - Roll form aluminum screen frame with sunscreen mesh
 - Roll form aluminum screen frame with stainless steel 0.009" thickness mesh
- ◇ **Glazing**
 - Capillary tubes
 - Argon gas
 - Wide variety of glazing, tinting and thickness options
- ◇ **Panning & Trim Choices**
 - Wide variety of panning, receptor and trim available
- ◇ **Mulling**
 - Wide variety of structural mulls

BENEFITS

- ◇ The capacity to match exterior colors for unique project facades
- ◇ The ability to facilitate large sizes for taller and wider window openings

PERFORMANCE

- ◇ Structural & Thermal (test reports or thermal simulations available upon request)

Model	Double Hung	Single Hung
AAMA/WDMA/CSA 101/IS.2/A440-08 Rating	R-40	R-35
Structural Load P.S.F.	60.15	52.63
Air at 50 MPH (cfm/ft ²)	0.16	0.1
Water (No Penetration) P.S.F.	7.52	5.43
U-Value (with Low-E and Argon)	0.25-0.29	0.25-0.29
SHGC (with Low-E and Argon)	0.14-0.32	0.14-0.33
Window Test Size	40" × 63"	40" × 63"

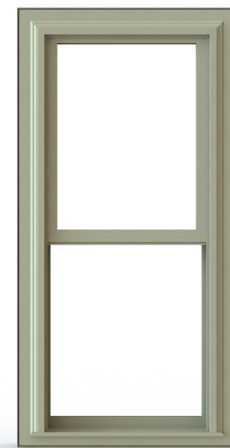

Our products are tested to the standards of and certified by the American Architectural Manufacturer's Association, the National Fenestration Rating Council and the Window & Door Manufacturers Association.



QUAKER
COMMERCIAL WINDOWS AND DOORS

VINYL COLORS AND ARCHITECTURAL EXTERIOR PAINT COATINGS AND FINISHES

◇ Solid Vinyl Colors (interior & exterior)



White



Sandstone



Beige

◇ Optional Faux Wood Grain (interior only)



Dark Oak (available with white or painted exterior only)

◇ Optional Painted Colors (exterior only)



Holly Green



Redwood



Chestnut



Satin Creme



Dark Bronze



Toffee



Earthone



Black



White



Sandstone



Beige



Resembles
Clear Anodized

◇ Optional Unlimited Custom Painted Colors (exterior only)



* Printed colors shown here may not accurately depict actual vinyl or painted colors. Color samples are available upon request.

Our products are tested to the standards of and certified by the American Architectural Manufacturer's Association, the National Fenestration Rating Council and the Window & Door Manufacturers Association.



QUAKER
COMMERCIAL WINDOWS AND DOORS



QUAKER
COMMERCIAL WINDOWS AND DOORS

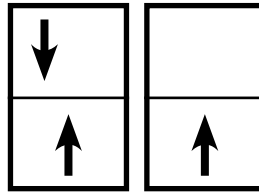

Manchester
SERIES

Manchester Series
R-40/R-35
3 1/4" Frame Depth
Double Hung/Single Hung

MANCHESTER DOUBLE HUNG

This document contains confidential and proprietary information intended for the private use of Quaker.
© 2016 Quaker Window Products Co., INC. All rights reserved.
Quaker reserves the right to change any/all designs without notice. Due to periodic re-certification requirements, result shown may vary.

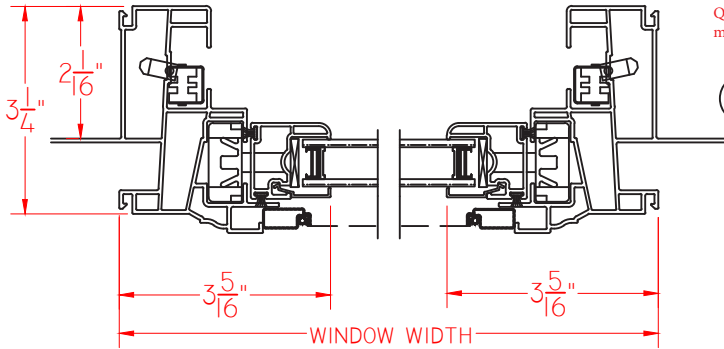

Ⓐ VERTICAL CROSS SECTION

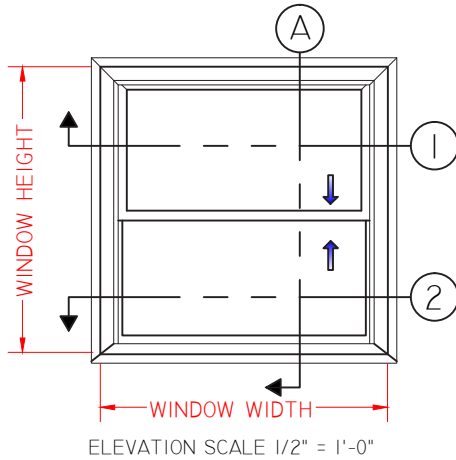
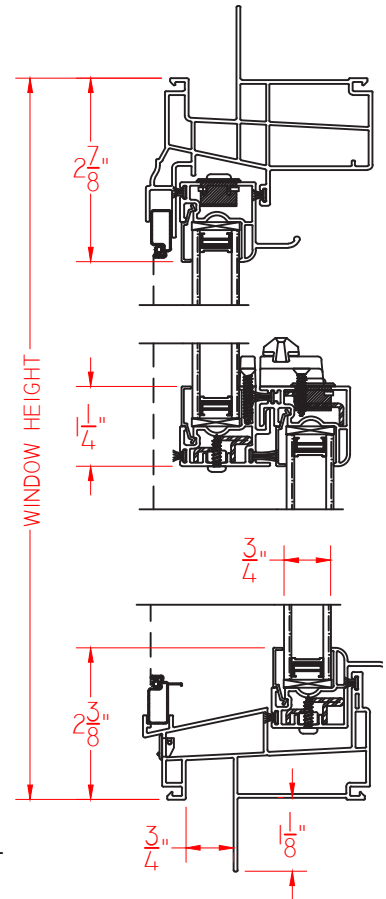

② HORIZONTAL CROSS SECTION

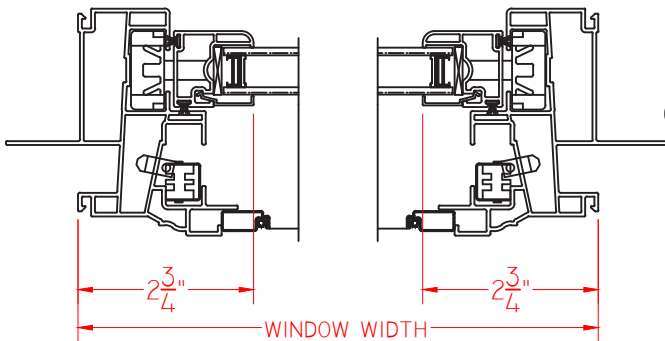

SCALE 1:3

Our products are tested to the standards of and certified by the American Architectural Manufacturer's Association, the National Fenestration Rating Council and the Window & Door Manufacturers Association.



QUAKER
COMMERCIAL WINDOWS AND DOORS