

February 18, 2021

CERTIFICATE OF APPROPRIATENESS

Gary Wilson
Wilson Construction Company
2790 Island View Road
Traverse City MI 49686

RE: Application Number 21-7055; 3960 Third; Willis-Selden Historic District

Dear Mr. Wilson,

At the regular scheduled meeting held on February 10, 2021, the Detroit Historic District Commission (“Commission”) reviewed the above-referenced application for building permit. Pursuant to Section 5(10) of the Michigan Local Historic District Act, as amended, being MCL 399.205, MSA 5-3407(5)(10) and Section 21-2-73 of the 2019 Detroit City Code; the Commission reviewed the above-referenced application for building permit and hereby issues a Certificate of Appropriateness, which is effective as February 18, 2021.

The following proposed work meets the defined elements of design for the historic district and the Secretary of the Interior’s Standards for Rehabilitation and guidelines for rehabilitating historic buildings (36 CFR Part 67).

West/Front Elevation

- **Color Change:** The applicant proposes to repaint the elevation Benjamin Moore, Raven, which is close to B:19 – Black. *Previously approved color was Benjamin Moore, Chelsea Gray, which is close to B:10 - Grayish Green and is still listed on the current elevation.*
- **Storefront Alteration:** The brick in the two openings (as seen in the 2019 photograph) has been removed, per the approval given in the original application.
Selected storefront system: Kawneer 451 & 451T (Thermal) Framing System; Selected Entry System: Kawneer, 190 Narrow Style Entrance. Color: black.
 - The right and left openings will be identical in design with fixed aluminum storefront frames, insulated fixed glass and central mullions. Each opening will be six glass panels wide and four glass panels high. *Previous approval included storefront system with folding windows below fixed glass panels (right opening); and folding and fixed panel storefront system/entry door below fixed glass panels (left opening).*
 - The existing limestone sills will be replaced with new 4” limestone sills (to match existing). Brick veneer will remain below the sills.
 - The center opening will contain two out-swing doors (each 3’-11” x 9’-0” aluminum frame will have two glass panels wide and three glass panels high with solid bottom panel, color: black). Sidelights (one panel wide and four panels high - solid bottom panel and three glass panels) and transom (six glass panels wide and two glass panels high) with central mullion will fill the remaining opening. *Previous approval included a new aluminum and glass garage door.*
 - Four swan neck lighting fixtures (indicated by circles) will be installed, color: black.

East/Rear Elevation

- The north window opening will remain bricked/blocked in as it currently exists. *Previous approval specified glass block to fill the existing opening.*

- The south opening that has brick and concrete block will be replaced with brick. The existing, non-original pedestrian door will be bricked in to match the existing wall surface. *Previous approval proposed the brick and concrete block to remain, and a new pedestrian door.*
- The currently existing rolling garage door opening will be partially filled with a wall and will also include a small roll-up/coil door and pedestrian door (3'-0" x 7'-0" insulated egress door, solid and smooth aluminum face). The wall and pedestrian door surfaces will be faced with metal siding. Material: ATAS Rigid Wall, smooth surface, color: black. According to the submitted product literature, the panels are 15/16" deep and have 1-5'8" wide ribs. The fastening system offers uninterrupted vertical or horizontal sight lines; this application will be installed horizontally. *Previous approval included a new insulated aluminum overhead garage door.*
 - The Thermisor rolling door will have flat slats and be black in color.
 - Two wall-mounted LED light fixtures will be installed on the rear elevation.

Side Elevations (North/South)

- No changes proposed from previously approved application.

The COA was issued with the following conditions:

- Where new brick is needed, the new brick shall match the existing brick in color, dimension, texture and pattern. A historic mortar mix shall be used, even if new brick (rather than reclaimed historic brick) is used. Please refer to the National Park Service Technical Preservation Services Preservation Brief "*Repointing Mortar Joints in Historic Masonry Buildings*".
- The elevations call out the Centria wall system, however the second page of the data sheets say the ATAS Rigid Wall System will be used. The drawings should be revised to state the selected system.
- The rear elevation also specifies the rigid wall system will be applied to the flat surface pedestrian door, but this application to the door is not reflected on the wall section.
- If the paint is to be removed from the rear elevation, the method of paint removal for the peeling brick must be specified.
- The above items will be submitted for staff review. Should revised plans deviate from the scope of work presented within this staff report; staff may require the applicant to resubmit the project for review at an upcoming HDC meeting.

Please retain this COA for your files. You should now proceed to obtain a building permit from the City of Detroit Buildings, Safety, Engineering and Environmental Department. It is important to note that approval by the Detroit Historic District Commission does not waive the applicant's responsibility to comply with any other applicable ordinances or statutes.

For the Commission:



Audra Dye
Staff, Historic District Commission

RE: Application 19-6538 – 3960 Third Avenue, Willis Selden HD

Request to modify work approved in COA issued December 18, 2019. The modifications will retain more of the existing/historic appearance than what was originally approved. Please see the attached revised drawings.

West/Front Elevation

- Paint color – the HDC approved Benjamin Moore, Chelsea Gray as it was close to B:10 – Grayish Green – NOTE that the enclosed drawings still indicate this color BUT
 - o It is requested for permission to change the paint color to “Raven” which is part of the tenant branding color. It is close to B:19 – Black



- Storefront windows – originally approved - removal of the brick and installation of black aluminum folding storefronts with a door in the north half of the building
 - o It is requested for permission to install black aluminum storefront that is fixed and subdivided per the attached drawings. The revised configuration does not contain a doorway in the north half of the façade as requested originally, the two window openings will be identical.
 - o Per the Commission’s condition the limestone panels below the storefront windows have been removed from the project – the existing limestone sills on the window openings will be replaced to match the existing with brick below.
- Garage door opening – originally approved – an overhead glass garage door – HOWEVER the Fire Marshall will not allow an overhead door for egress – assurances were made that the door would be kept open anytime there was someone in the building, but the Fire Marshall is requiring outward swinging pedestrian doors for egress. The team looked at a number of options for egress including 1) adding a door to the side – however the building is constructed on the property line and the building owner does not own the lots on either side and the lot owners would not grant an easement. 2) retaining the existing pedestrian door in the façade,

however there is not enough interior space to create a fire rated egress corridor. 3) Using the façade design that was originally approved with a door in the northwest corner, but it was not possible to put a fire rated egress corridor to this door either.

- THEREFORE - It is requested for permission to install an aluminum and glass storefront system with two doors within the existing opening. The doors and storefront will have mullions in order for the entire system to appear as a glass garage door. The storefront will be at the same plane as the existing garage door. This design has been approved by the easement holder on the building, the Michigan Historic Preservation Network.

East/Rear Elevation

- It is requested to leave the north window opening bricked/blocked in as currently exists
- In the existing garage door opening it is proposed to fill in part of the opening with a wall in order to accommodate a smaller overhead door and a pedestrian door. The wall and pedestrian door surfaces will be sided in metal siding to match the overhead door and thereby imitating a large overhead garage door within the existing opening. The overhead door and cladding will be black in color to match the façade storefront frames.
- It is requested to block in the existing, non-original pedestrian door located to the south of the existing garage door opening to match the existing wall surface.

Shop drawings and specifications for the storefront system and rear overhead door and siding are included with this request.





Fill in this door to match existing wall surface

Retain opening- install metal overhead door, wall surface and pedestrian door – both to be sided to match metal overhead door and read as one large overhead door

Repair to match existing

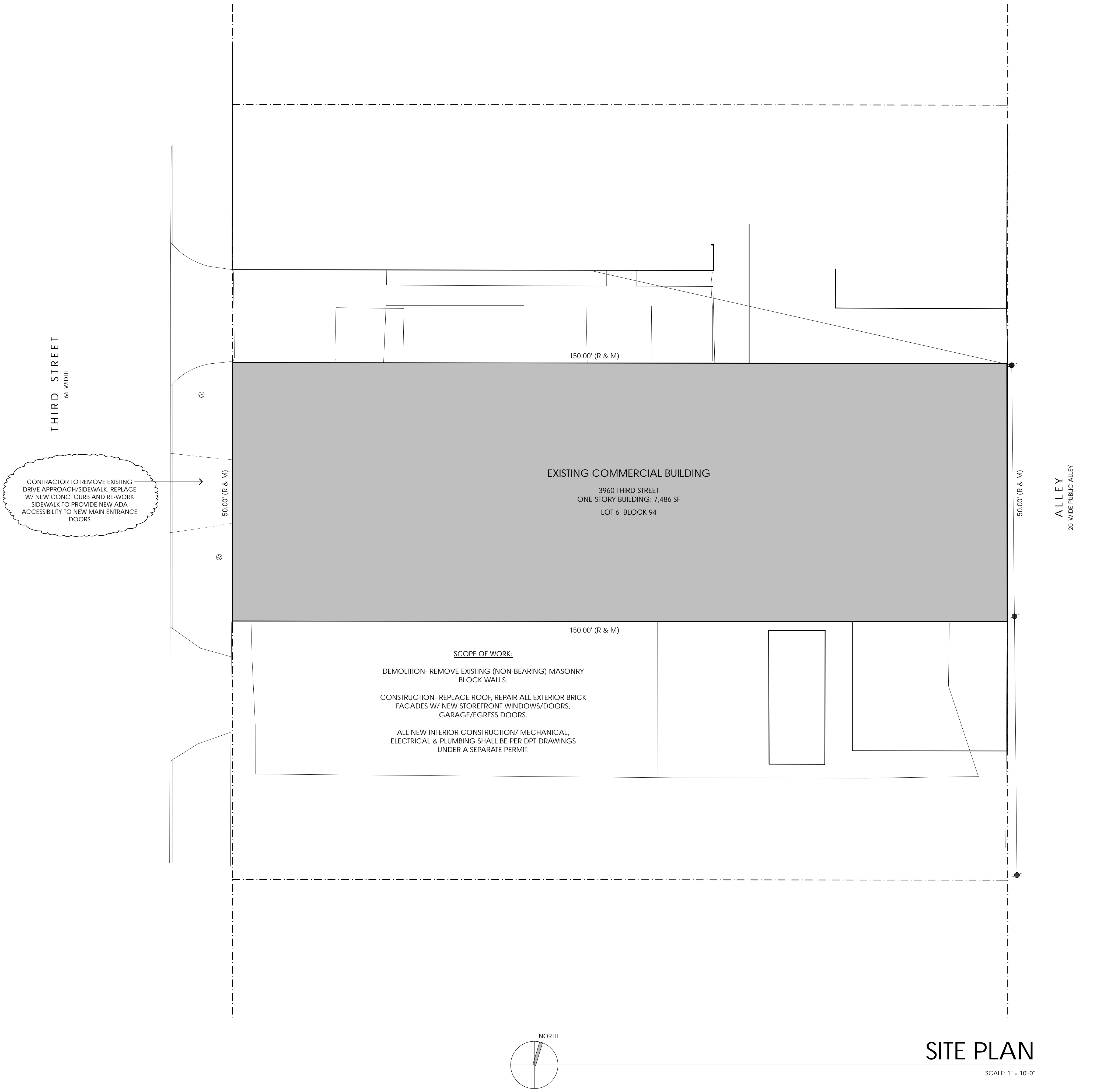

BUILDING RENOVATION

3960 THIRD STREET
DETROIT, MICHIGAN

ARCHITECTURAL SHEET INDEX:

SITE PLAN	AS00
ALTA SURVEY	1
DEMOLITION PLAN	D101
FLOOR PLAN	A101
EAST/WEST ELEVATIONS	A200
NORTH/SOUTH ELEVATIONS	A201
DPT: ALLEY WALL SECTIONS	A4.3

APPLICABLE BUILDING CODES:

2015 MICHIGAN BUILDING CODE
 2015 MICHIGAN MECHANICAL CODE
 2015 MICHIGAN PLUMBING CODE
 2015 INTERNATIONAL FUEL & GAS CODE
 2015 INTERNATIONAL FIRE CODE
 NEC 2014 MICHIGAN ELECTRICAL CODE WITH PART 8 AMENDMENTS
 MICHIGAN BARRIER FREE-ADAAG, ICC/ANSI A117.1-2009 AND/OR
 AS REQUIRED BY THE CITY OF DETROIT
 2015 MICHIGAN ENERGY CODE

CODE REVIEW:

Use Groups: Section 302
 Business (B)

General Building Heights & Areas: Section 503	Permitted SF	Actual SF
Business (B)	9,000 SF	7,486 SF
Business (B)	Permitted Height	Actual Height
Business (B)	2 story	1 story

NON-SUPPRESSED BUILDING (NO FIRE SUPPRESSION REQUIRED)

Construction classification: Section 602
 Construction Type 5B
 Fire Resistance Rating for Building:

Primary structural frame	0-hour
Bearing walls (exterior)	0-hour
Nonbearing walls/partitions	0-hour
Floor construction/secondary members	0-hour
Roof construction/secondary members	0-hour

General Means of Egress
 Occupant Load: Section 1004

Business	7,486 SF / 100 gross =	75 occupants
----------	------------------------	--------------

Exit and Exit Access Doorways: Section 1015

Business	two means of egress	(required/ provided)
----------	---------------------	----------------------

ALL PLUMBING CODE INFORMATION IS BASED ON 2015 MICHIGAN PLUMBING CODE
 Minimum Plumbing Facilities: Section 403

Men restroom: Business (B) (1 per 25, 1 per 40)
 38 men: 1 wc, 1 urinal, 1 lav (required/ provided)

Women restroom: Business (B) (1 per 25, 1 per 40)
 38 women: 2 wc, 1 lav. (required/ provided)

(1) service sink provided

SITE PLAN

SCALE: 1" = 10'-0"

THIRD STREET

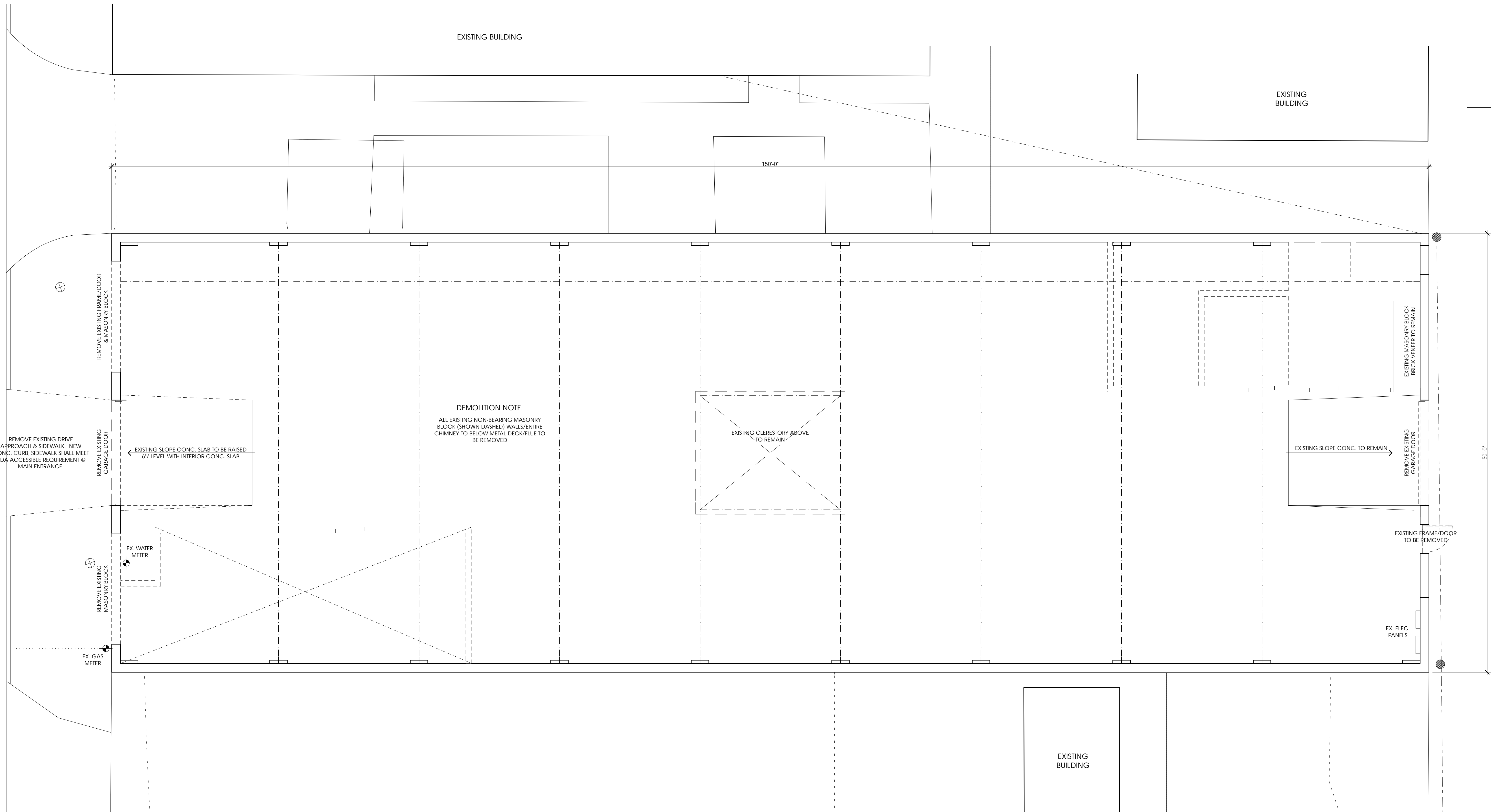

EXISTING BUILDING

EXISTING BUILDING

150'-0"

DEMOLITION NOTE:
 ALL EXISTING NON-BEARING MASONRY
 BLOCK (SHOWN DASHED) WALLS/ENTIRE
 CHIMNEY TO BELOW METAL DECK/FLUE TO
 BE REMOVED

EXISTING CLERESTORY ABOVE
TO REMAIN

EXISTING SLOPE CONC. TO REMAIN

EXISTING FRAME/DOOR
TO BE REMOVED

EX. ELEC.
PANELS

REMOVE EXISTING FRAME/DOOR
& MASONRY BLOCK

REMOVE EXISTING
GARAGE DOOR

REMOVE EXISTING
MASONRY BLOCK

EX. GAS
METER

EX. WATER
METER

← EXISTING SLOPE CONC. SLAB TO BE RAISED
6" LEVEL WITH INTERIOR CONC. SLAB

REMOVE EXISTING DRIVE
APPROACH & SIDEWALK. NEW
CONC. CURB, SIDEWALK SHALL MEET
ADA ACCESSIBLE REQUIREMENT @
MAIN ENTRANCE.

HF:architecture®
 HARMONY | FORM

512 NORTH MAIN STREET | SUITE 100
 ROYAL OAK | MICHIGAN 48067
 248 | 388 | 8563 | www.hfarchitecture.com

ISSUE DATE
 09.23.20
 12.09.20

ISSUE FOR
 HDC + MHPN FACADE APPROVAL
 EXTERIOR CONSTRUCTION PACKAGE ONLY

PROJECT
 THIRD STREET BUILDING RENOVATION
 3960 THIRD STREET
 DETROIT, MICHIGAN

50'-0"

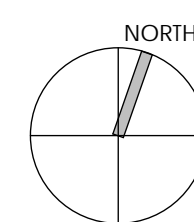

DEMOLITION PLAN

SCALE: 3/16" = 1'-0"

D101

THIRD STREET

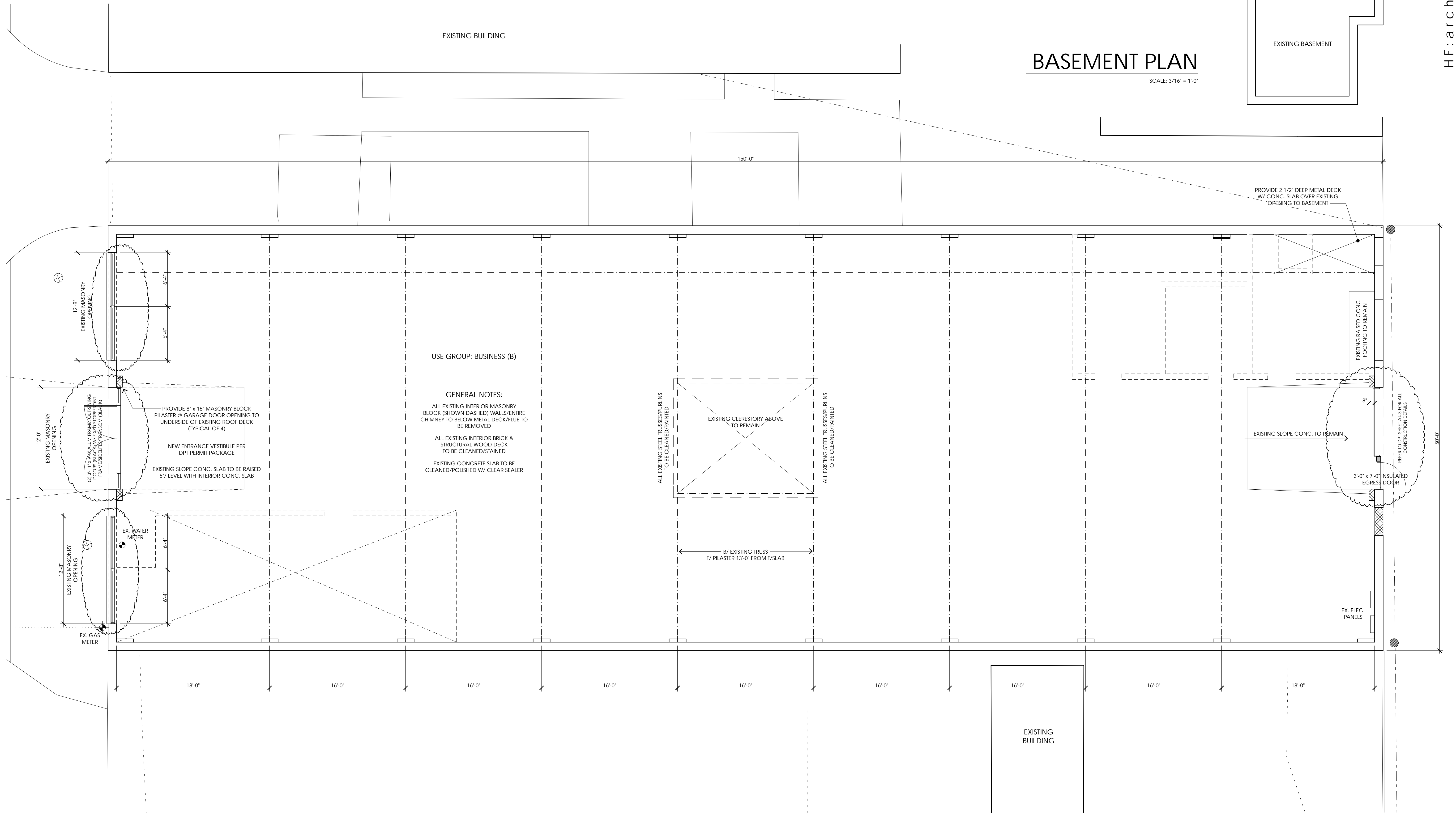

EXISTING BUILDING

BASEMENT PLAN

SCALE: 3/16" = 1'-0"

OPENING TO FIRST LEVEL
(NO STAIR CURRENTLY)

EXISTING BASEMENT

PROVIDE 2 1/2" DEEP METAL DECK
W/ CONC. SLAB OVER EXISTING
OPENING TO BASEMENT

USE GROUP: BUSINESS (B)

GENERAL NOTES:

- ALL EXISTING INTERIOR MASONRY BLOCK (SHOWN DASHED) WALLS/ENTIRE CHIMNEY TO BELOW METAL DECK/FLUE TO BE REMOVED
- ALL EXISTING INTERIOR BRICK & STRUCTURAL WOOD DECK TO BE CLEANED/STAINED
- EXISTING CONCRETE SLAB TO BE CLEANED/POLISHED W/ CLEAR SEALER

ALL EXISTING STEEL TRUSSES/PURLINS TO BE CLEANED/PAINTED

EXISTING CLERESTORY ABOVE TO REMAIN

ALL EXISTING STEEL TRUSSES/PURLINS TO BE CLEANED/PAINTED

B/ EXISTING TRUSS
T/ PILASTER 13'-0" FROM T/SLAB

EXISTING RAISED CONC. FOOTING TO REMAIN

EXISTING SLOPE CONC. TO REMAIN

REFER TO DPT SHEET A1.3 FOR ALL CONSTRUCTION DETAILS

3'-0" x 7'-0" INSULATED EGRESS DOOR

EX. ELEC. PANELS

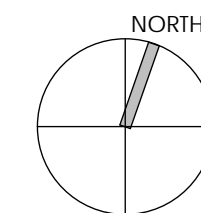

FLOOR PLAN

SCALE: 3/16" = 1'-0"

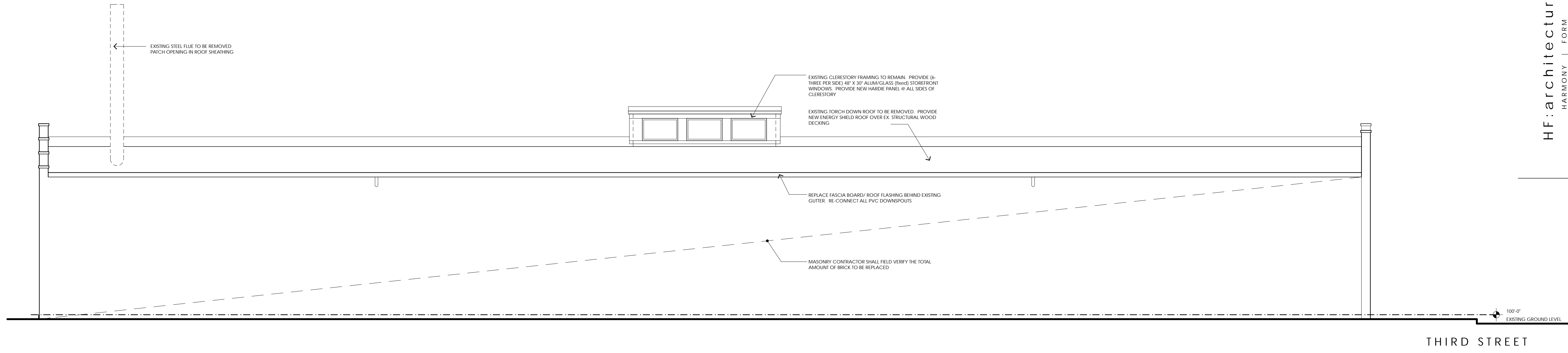

NORTH ELEVATION
SCALE: 3/16" = 1'-0"

THIRD STREET

ISSUE DATE
09.23.20
12.09.20

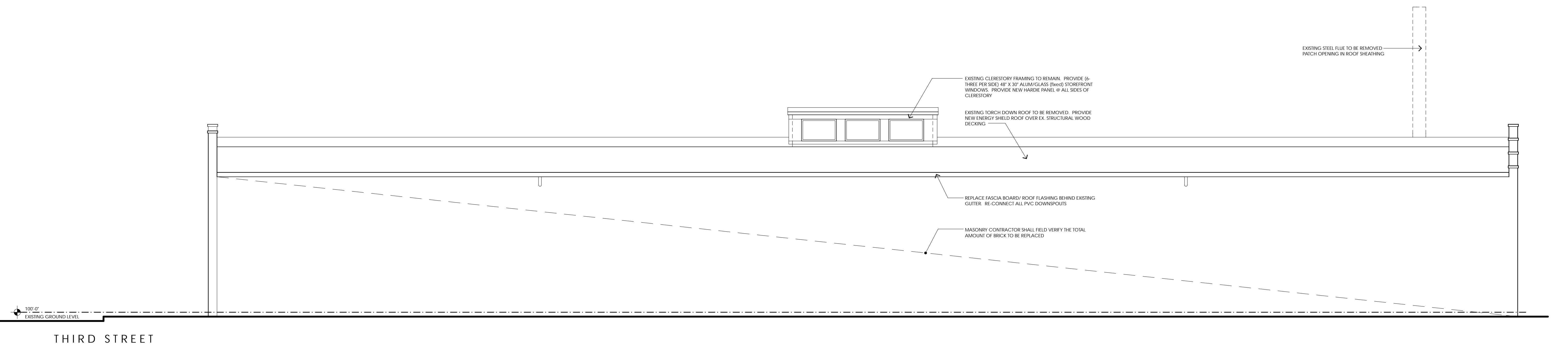

SOUTH ELEVATION
SCALE: 3/16" = 1'-0"

THIRD STREET

ISSUE FOR
HDC + MHPN FACADE APPROVAL
EXTERIOR CONSTRUCTION PACKAGE ONLY

PROJECT
THIRD STREET BUILDING RENOVATION
3960 THIRD STREET
DETROIT, MICHIGAN

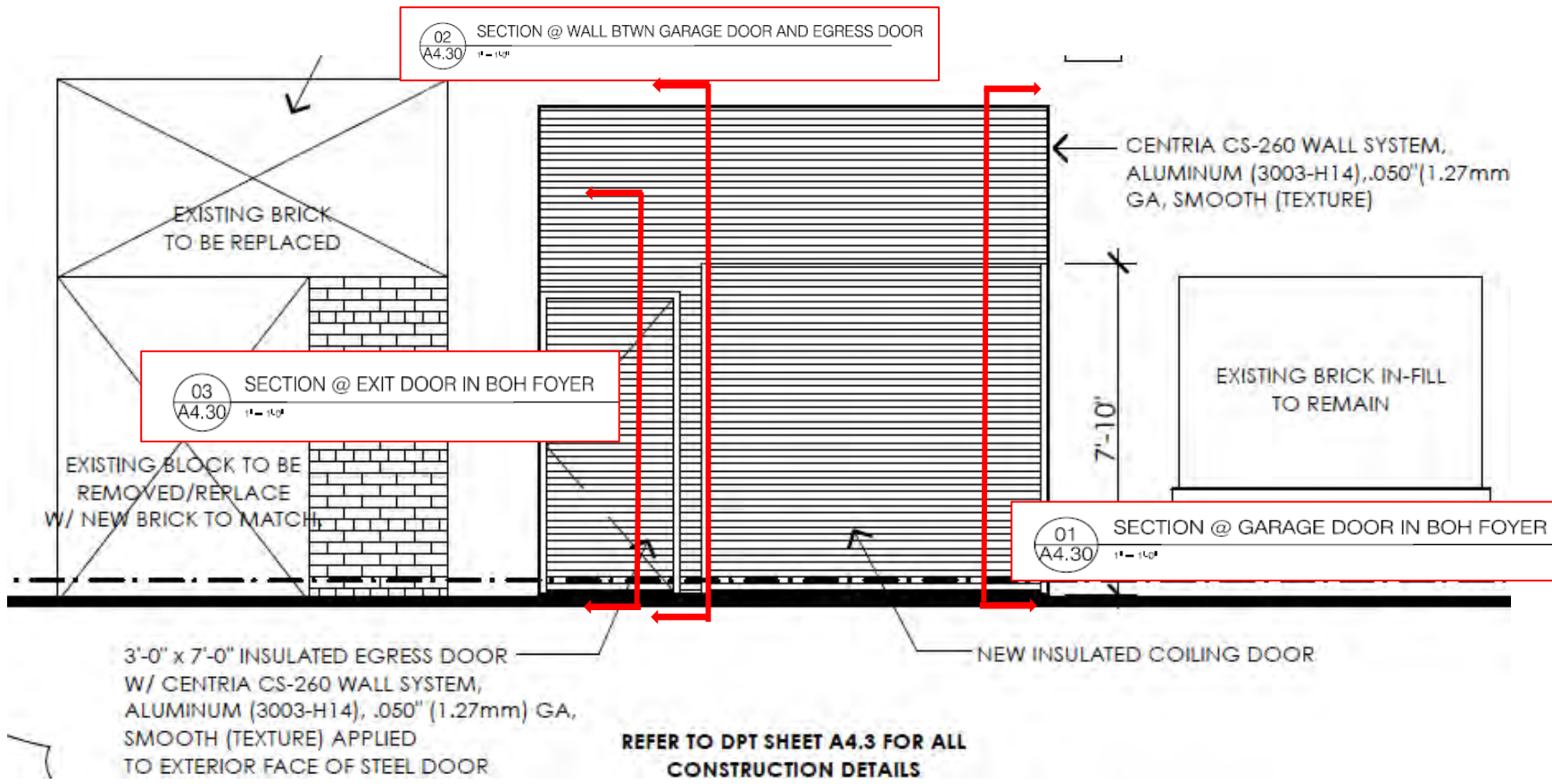

This document identifies the areas of the wall sections shown on the following page.

190, 350 AND 500 STANDARD ENTRANCES



Single-Source Packages Generate Versatile First Impressions



Curtis Culwell Center
Garland, Texas
ARCHITECT
HKS, Inc., Dallas, Texas
GLAZING CONTRACTOR
B & B Glass, Inc., Dallas, Texas
PHOTOGRAPHER
© Blake Marvin – HKS

Tough yet attractive, Kawneer's Standard Entrances are designed as a single-source package of door, door frame and hardware that is easily adaptable to custom requirements. Designed to complement new or remodel construction as well as modern or traditional architecture, they are engineered, constructed and tested to make a good first impression while withstanding the rigors of constant use by occupants and visitors.

PERFORMANCE

To resist both lever arm and torsion forces that constantly act on any door, all three entrances feature welded corner construction with Sigma deep penetration and fillet welds plus mechanical fastenings at each corner – a total of 16 welds per door. Each door corner comes with a limited lifetime warranty, good for the life of the door under normal use. It is transferable from building owner to owner and is in addition to the standard two-year warranty covering material and workmanship of each Kawneer door.



1. Thermoplastic elastomer weatherstrip in blade stop of frame jams, header or transom bar.
2. Integral polymeric fin attached to adjustable astragal, creating an air barrier between pairs of doors.
3. Optional surface-applied bottom weatherstrip with flexible blade gasket. Extruded raised lip on threshold to provide continuous contact for bottom weatherstrip.
4. Standard 1/4" beveled glass stops to sheet water and dirt off without leaving residue.
5. Available in all finishes offered by Kawneer.

GENERAL

- Heights vary up to 10'; widths range from approximately 3' to 4'
- Door frame face widths range to a maximum of 4", while depths range to 6"
- Door operation is single- or double-acting with maximum security locks or touch bar panics standard
- Architect's classic 1" round, bent bar push/pull hardware is available in various finishes and sizes
- Infills range from 1/4" to 1"

FOR THE FINISHING TOUCH

Architectural Class I anodized aluminum finishes are available in clear and Permanodic® color choices.

Painted finishes, including fluoropolymer, that meet AAMA 2605 are offered in many standard choices and an unlimited number of specially designed colors.

Solvent-free powder coatings add the "green" element with high performance, durability and scratch resistance that meet the standards of AAMA 2604.

ECONOMY

Kawneer's bulb neoprene weatherstripping forms a positive seal around the door frame and provides a substantial reduction in air infiltration, resulting in improved comfort and economies in heating and cooling costs. The system is wear- and temperature-resistant and replaces conventional weatherproofing. The bottom weatherstrip at the interior contains a flexible blade gasket to meet and contact the threshold, enhancing the air and water infiltration performance characteristics.

190 NARROW STILE ENTRANCE

- Is engineered for moderate traffic in applications such as stores, offices and apartment buildings
- Vertical stile measures 2-1/8", top rail 2-1/4" and bottom rail **24"**
- Results in a slim look that meets virtually all construction requirements

350 MEDIUM STILE ENTRANCE

- Provides extra strength for applications such as schools, institutions and other high-traffic applications
- Vertical stiles and top rails measure 3-1/2"
- Bottom rail measures 6-1/2" for extra durability

500 WIDE STILE ENTRANCE

- Creates a monumental visual statement for applications such as banks, libraries and public buildings
- Vertical stiles and top rail measures 5"; bottom rail measures 6-1/2"
- Results in superior strength for buildings experiencing heavy traffic conditions

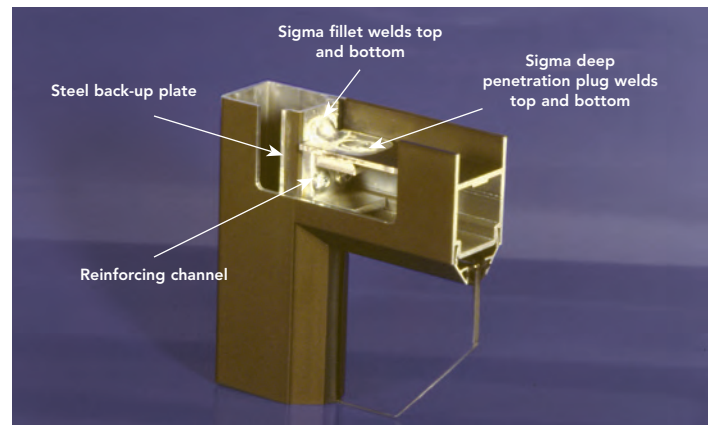

TRIFAB® VG (VERSAGLAZE®)
TRIFAB® VG 450 | 451 & 451T (THERMAL) FRAMING SYSTEMS &
TRIFAB® 451UT (ULTRA THERMAL) FRAMING SYSTEM



Design + Performance

Versatility with Unmatched Fabrication Flexibility



Geisinger Professional Building
Jenkins Township, Pennsylvania
ARCHITECT
Mericle Commercial Real Estate Services
Wilkes-Barre, Pennsylvania
GLAZING CONTRACTOR
Sterling Glass, Inc., Scranton, Pennsylvania
PHOTOGRAPHER
© Perzel Photography Group

Trifab® VersaGlaze® is built on the proven and successful Trifab® platform – with all the versatility its name implies. There are enough framing system choices, fabrication methods, design options and performance levels to please the most discerning building owner, architect and installer. The 4.5" depth Trifab® VersaGlaze® Framing System family is available with non-thermal, thermal and ultra-thermal performance levels. The ultra-thermal Trifab® 451UT Framing System, is designed for the most demanding thermal performance and employs a dual Isolock® thermal break.

AESTHETICS

Trifab® VersaGlaze® Framing Systems offer designers a choice of front-, center-, back- or multi-plane glass applications. Structural silicone

glazing (SSG) and weatherseal glazing options further expand designers' choices, allowing for a greater range of possibilities for specific project requirements and architectural styles. All systems have a 4-1/2" frame depth; Trifab® VersaGlaze® 450 has 1-3/4" sightlines, while Trifab® VersaGlaze® 451/451T and Trifab® 451UT have 2" sightlines.

With seamless incorporation of Kawneer entrances or windows, including GLASSvent® visually frameless ventilators, Trifab® framing can be used on almost any project. These framing systems can also be packaged with Kawneer curtain walls and overhead glazing, thereby providing a full range of proven, and tested, quality products for the owner, architect and installer from a single-source supplier.

ECONOMY

Trifab® VersaGlaze® 450/451/451T/451UT Framing Systems offer a variety of fabrication choices to suit your project:

- **Screw Spline** – for economical continuous runs utilizing two-piece vertical members that provide the option to pre-assemble units with controlled shop labor costs and smaller field crews for handling and installation. (available for all systems)
- **Shear Block** – for punched openings or continuous runs using tubular moldings with shear block clips that provide tight joints for transporting large pre-assembled multi-lite units. (available for 450/451/451T systems)
- **Stick** – for fast, easy field fabrication. Field measurements and material cuts can be done when metal is on the jobsite. (available for 450/451/451T systems)
- **Pre-glazed** – The combination of screw spline construction with pre-glazing in the shop accelerates installation and reduces field labor time while minimizing disruption to the surrounding area or existing tenants. Making it an exceptional choice for new or retrofit applications, particularly in urban areas or where space is limited. (available for 451/451T/451UT framing)



Brighton Landing
Cambridge, Massachusetts
 ARCHITECT
ADD Inc., Cambridge, Massachusetts
 GLAZING CONTRACTOR
Ipswich Bay Glass Company, Inc., Rowley, Massachusetts
 PHOTOGRAPHER
 © **Gordon Schenck, Jr.**

All systems can be flush glazed from either the inside or outside. The weatherseal option provides an alternative to SSG vertical mullions for Trifab® VersaGlaze® 450/451/451T. This ABS/ASA rigid polymer extrusion allows complete inside glazing and creates a flush glass appearance on the building exterior without the added labor of scaffolding or swing stages. Additionally, high-performance flashing options are engineered to eliminate perimeter sill fasteners and associated blind seals.

FOR THE FINISHING TOUCH

Architectural Class I anodized aluminum and painted finishes in fluoropolymer (AAMA 2605) and solvent-free powder coatings (AAMA 2604) offer a variety of color choices.



PERFORMANCE

Kawneer’s IsoLock® thermal break technology creates a composite section, prevents dry shrinkage and is available on Trifab® VersaGlaze® 451T. For even greater thermal performance, a dual IsoLock® thermal break is used on Trifab® 451UT.

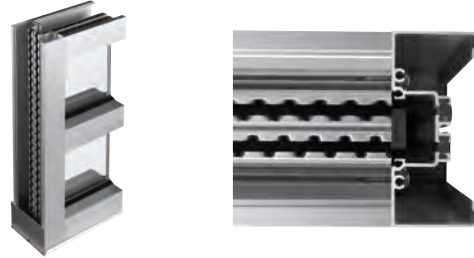

Trifab® 451UT uses a dual IsoLock® thermal break (right) and features a new high-performance sill design, which incorporates a screw-applied end dam (left), ensuring positive engagement and tight joints between the sill flashing and end dam.

U-factor, CRF values and STC ratings for Trifab® framing systems vary depending upon the glass plane application. Project-specific U-factors can be determined for each individual project. (See the Kawneer Architectural Manual or Kawneer.com for additional information.)

Thermal simulations showing temperature variations from exterior/cold side to interior/warm side.

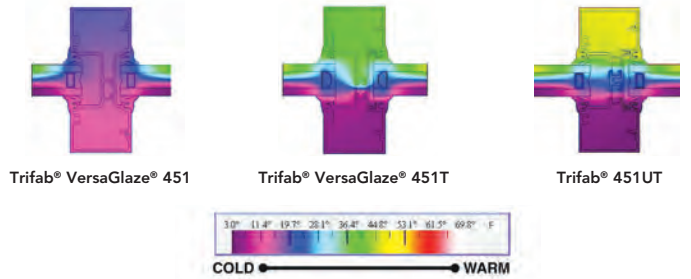

PERFORMANCE TEST STANDARDS



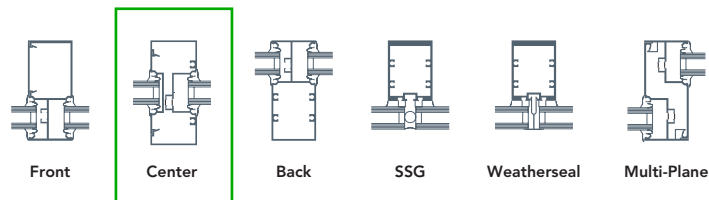

Air Infiltration	ASTM E283
Water	AAMA 501, ASTM E331
Structural	ASTM E330
Thermal	AAMA 1503
Thermal Break	AAMA 505, AAMA TIR-A8
Acoustical	AAMA 1801, ASTM E1425

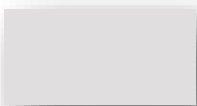
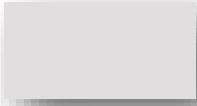
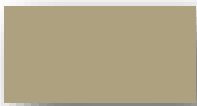

Kawneer Anodize finishes

Kawneer gives you a wide variety of anodized finishes with attractive alternatives. The benefit of a durable, anodized finish is married to the beauty of some very dynamic and exciting colors.

At the start of every design, there's a choice of how you want to finish. Contact your Kawneer sales rep for the information on these and other finishes available from Kawneer.

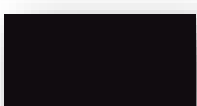
	KAWNEER FINISH NO.	COLOR	ALUMINUM ASSOCIATION SPECIFICATION	OTHER COMMENTS
	#14	CLEAR	AA-M10C21A41 / AA-M45C22A41	Architectural Class I (.7 mils minimum)
	#17	CLEAR	AA-M10C21A31	Architectural Class II (.4 mils minimum)
	#18	CHAMPAGNE	AA-M10C21A44	Architectural Class I (.7 mils minimum)
	#26	LIGHT BRONZE	AA-M10C21A44	Architectural Class I (.7 mils minimum)
	#28	MEDIUM BRONZE	AA-M10C21A44	Architectural Class I (.7 mils minimum)
	#40	DARK BRONZE	AA-M10C21A44 / AA-M45C22A44	Architectural Class I (.7 mils minimum)
	#29	BLACK	AA-M10C21A44	Architectural Class I (.7 mils minimum)

Third Street Building
 3960 Third St.
 Detroit, MI. 48201

Framing finish:
 • Black Anodized

Manufactures:
 • Kawneer Trifab 451/451 Thermal VG Fixed framing.
 • Kawneer 190 Narrow Stile Doors.
 • BAM-05 and BAM-09 Architectural Muntins.

Glass designation:
 T= 1" IGU SN68 $\frac{1}{4}$ " temp. - Air - Clear
 $\frac{1}{4}$ " Temp.
 A= 1" IGU SN68 $\frac{1}{4}$ " Ann. - Air - Clear
 $\frac{1}{4}$ " Ann.

Abbreviations:
 Temp. = Tempered
 F.S. = Frame Size
 R.O. = Rough Opening
 D.O. = Door Opening
 I.G.U. = Insulated Glass Unit
 H.W. = Hardware Set

Project Notes:

- Rough openings to be field verified.
- Drawings not to scale.
- All drawings viewed from the outside.
- Please review hardware sets as no hardware schedule was provided.
- No electrified hardware included at this time.
- Final cleaning by others.
- Please confirm finish.

1101 W HAMMOND ROAD
 TRAVERSE CITY, MI 49686
 Phone: 231-941-0050
 Fax: 231-941-2251



Project
 THIRD STREET

Sheet
 Cover Page

Drawn By
 Sam Braden
 Approved By

Date Issued
 1-14-21

File No.
 C18253

Sheet No.
 C1

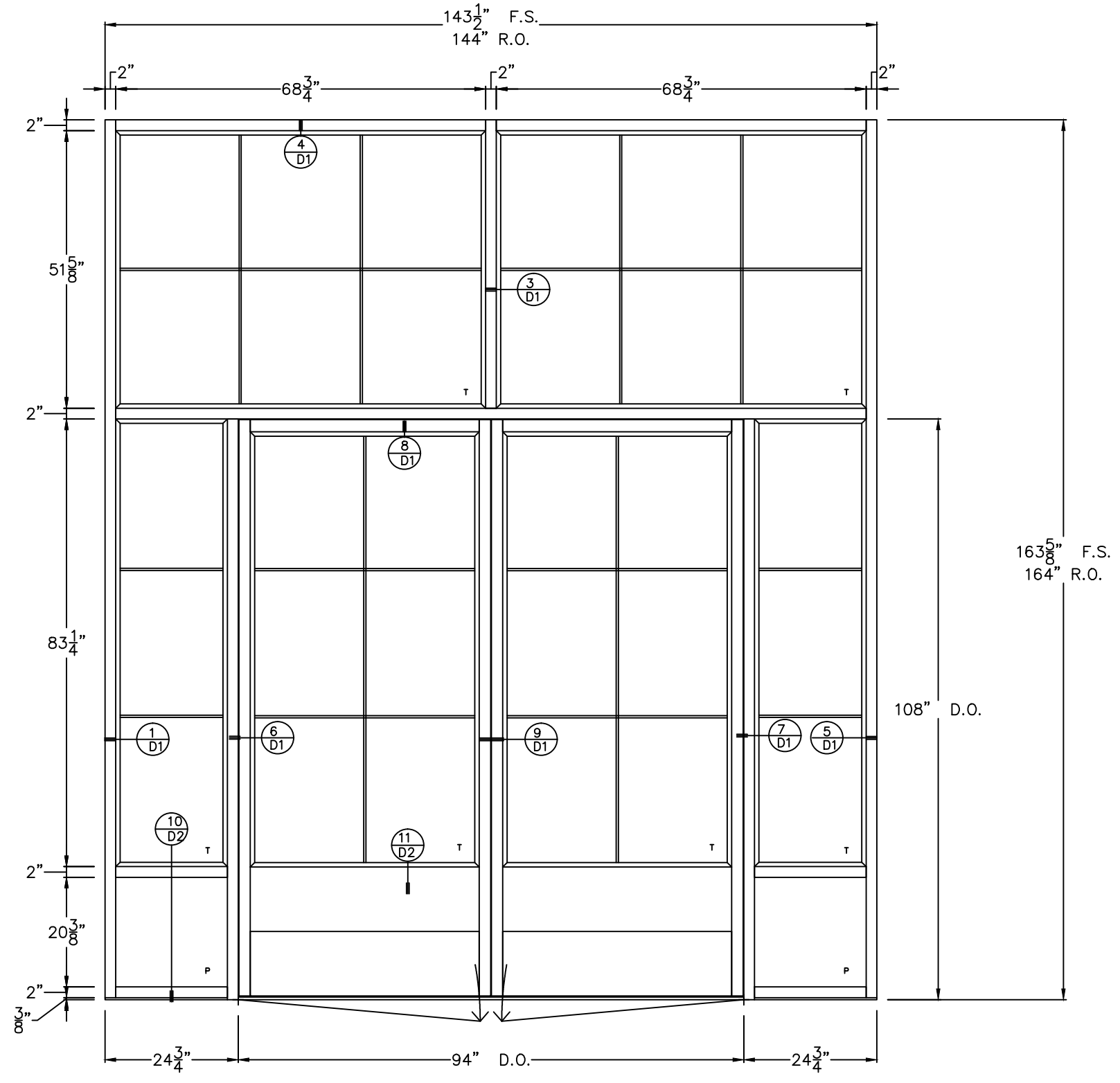

ENTRANCE QTY. REQD=1
 2 X 4 1/2" THERMAL-CENTER GLAZED-SCREW SPLINE-OUTSIDE GLAZED

1101 W HAMMOND ROAD
 TRAVERSE CITY, MI 49686
 Phone: 231-941-0050
 Fax: 231-941-2251



Project
 THIRD STREET

Sheet
 Elevation

Drawn By
 Sam Braden

Date Issued
 1-14-21

File No.
 C18253

Sheet No.
 E1

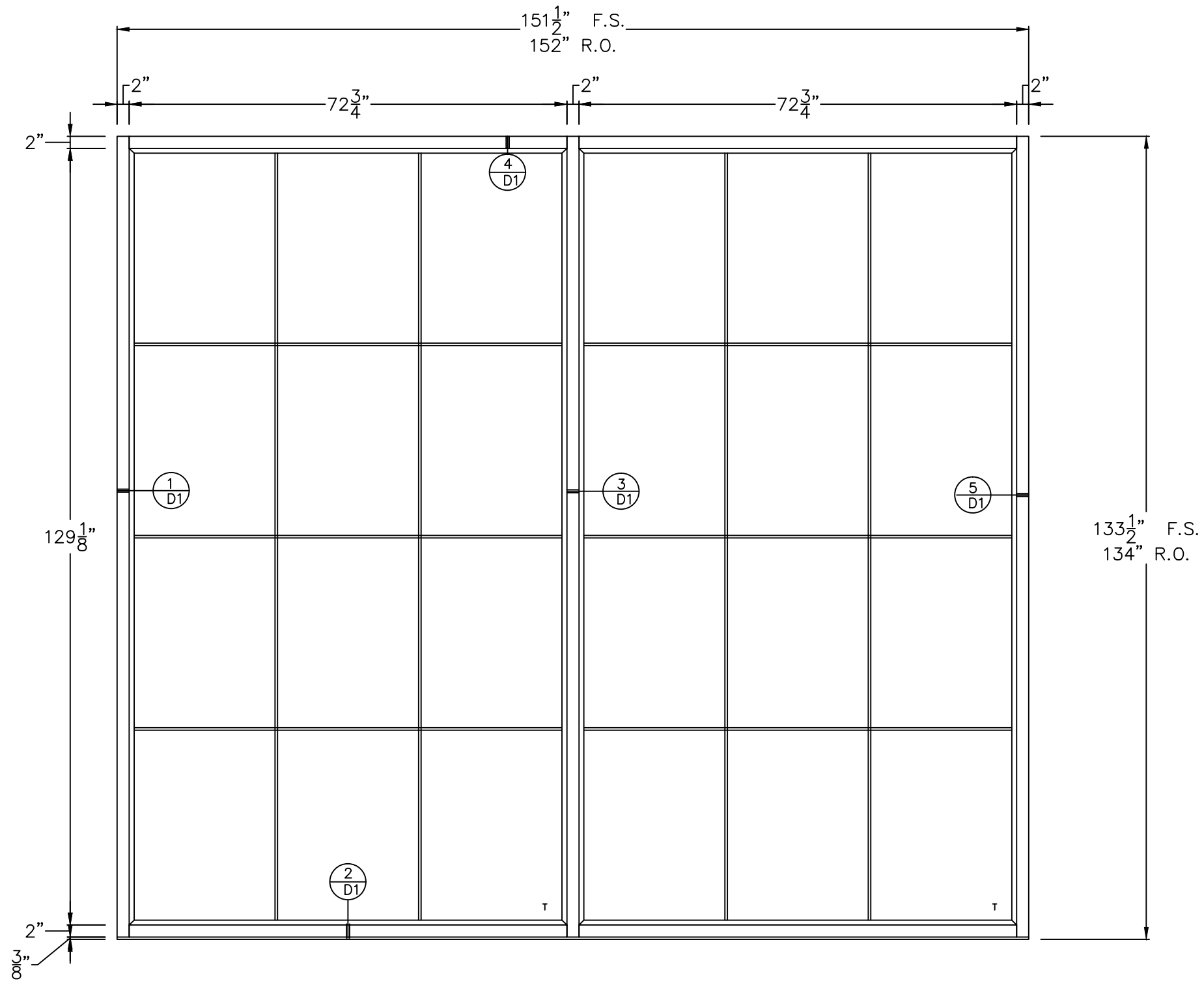

SIDE LITES QTY. REQD=2
 2 X 4 1/2" THERMAL-CENTER GLAZED-SCREW SPLINE-OUTSIDE GLAZED

1101 W HAMMOND ROAD
 TRAVERSE CITY, MI 49686
 Phone: 231-941-0050
 Fax: 231-941-2251



Project
 THIRD STREET

Sheet
 Elevation

Drawn By
 Sam Braden

Approved By

Date Issued
 1-14-21

File No.
 C18253

Sheet No.
 E2

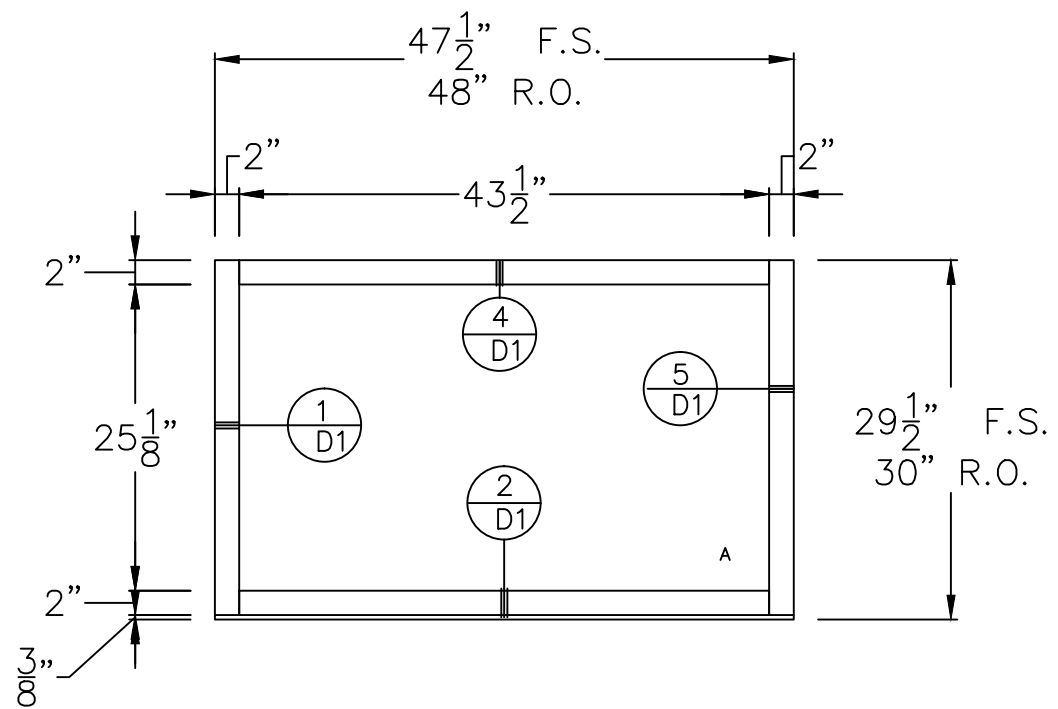

CLERESTORY QTY. REQD=6
 2 X 4 1/2" THERMAL-CENTER GLAZED-SCREW SPLINE-OUTSIDE GLAZED

1101 W HAMMOND ROAD
 TRAVERSE CITY, MI 49686
 Phone: 231-941-0050
 Fax: 231-941-2251



Project
 THIRD STREET

Sheet
 Elevation

Drawn By
 Sam Braden

Approved By

Date Issued
 1-14-21

File No.
 C18253

Sheet No.
 E3

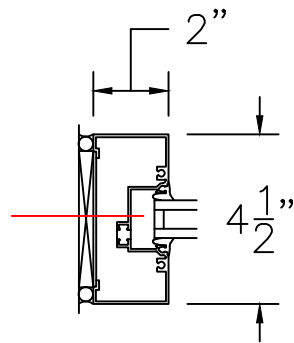

1 LEFT JAMB
D1

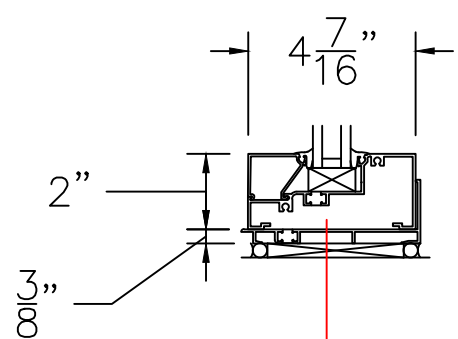

2 SILL
D1

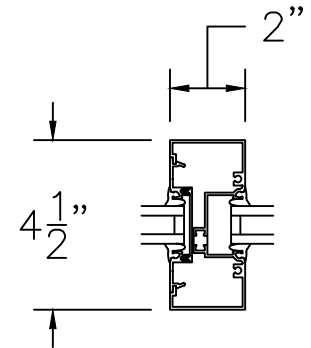

3 INTERMEDIATE VERTICAL
D1

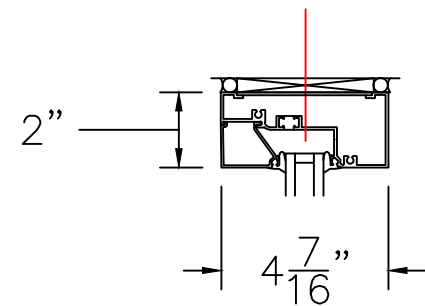

4 HEAD
D1

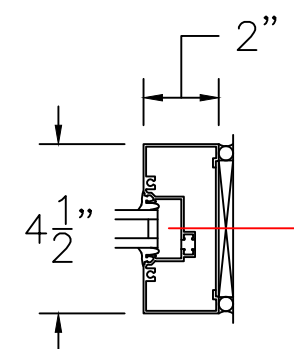

5 RIGHT JAMB
D1

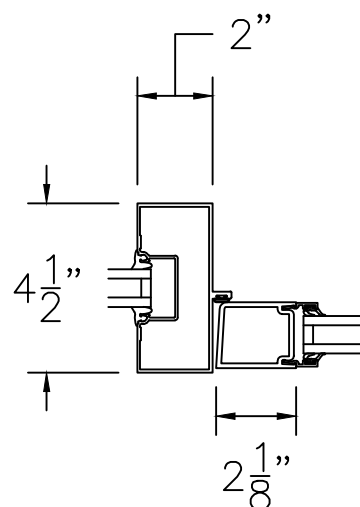

6 LEFT DOOR JAMB
D1

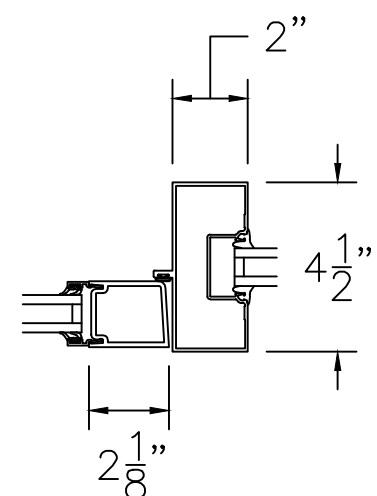

7 RIGHT DOOR JAMB
D1

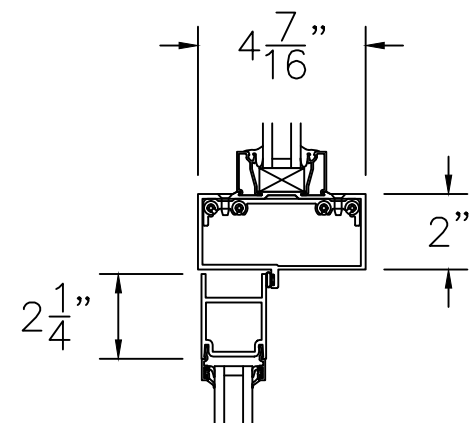

8 DOOR HEAD
D1

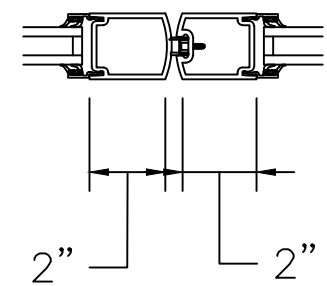

9 MEETING STILES
D1

1101 W HAMMOND ROAD
TRAVERSE CITY, MI 49686
Phone: 231-941-0050
Fax: 231-941-2251



Project
THIRD STREET

Sheet
Details

Drawn By
Sam Braden

Approved By
Date Issued
1-14-21

File No.
C18253

Sheet No.
D1

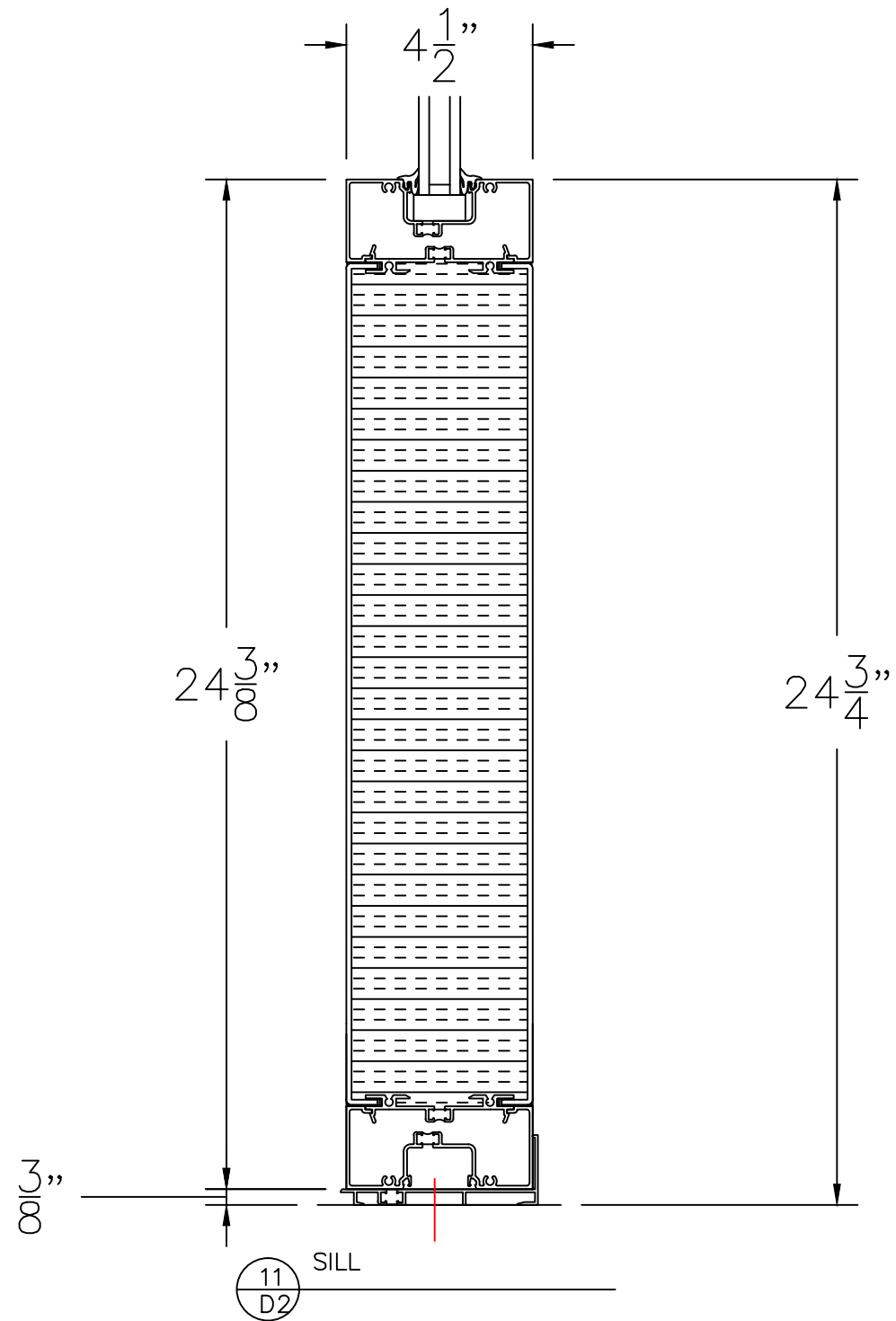
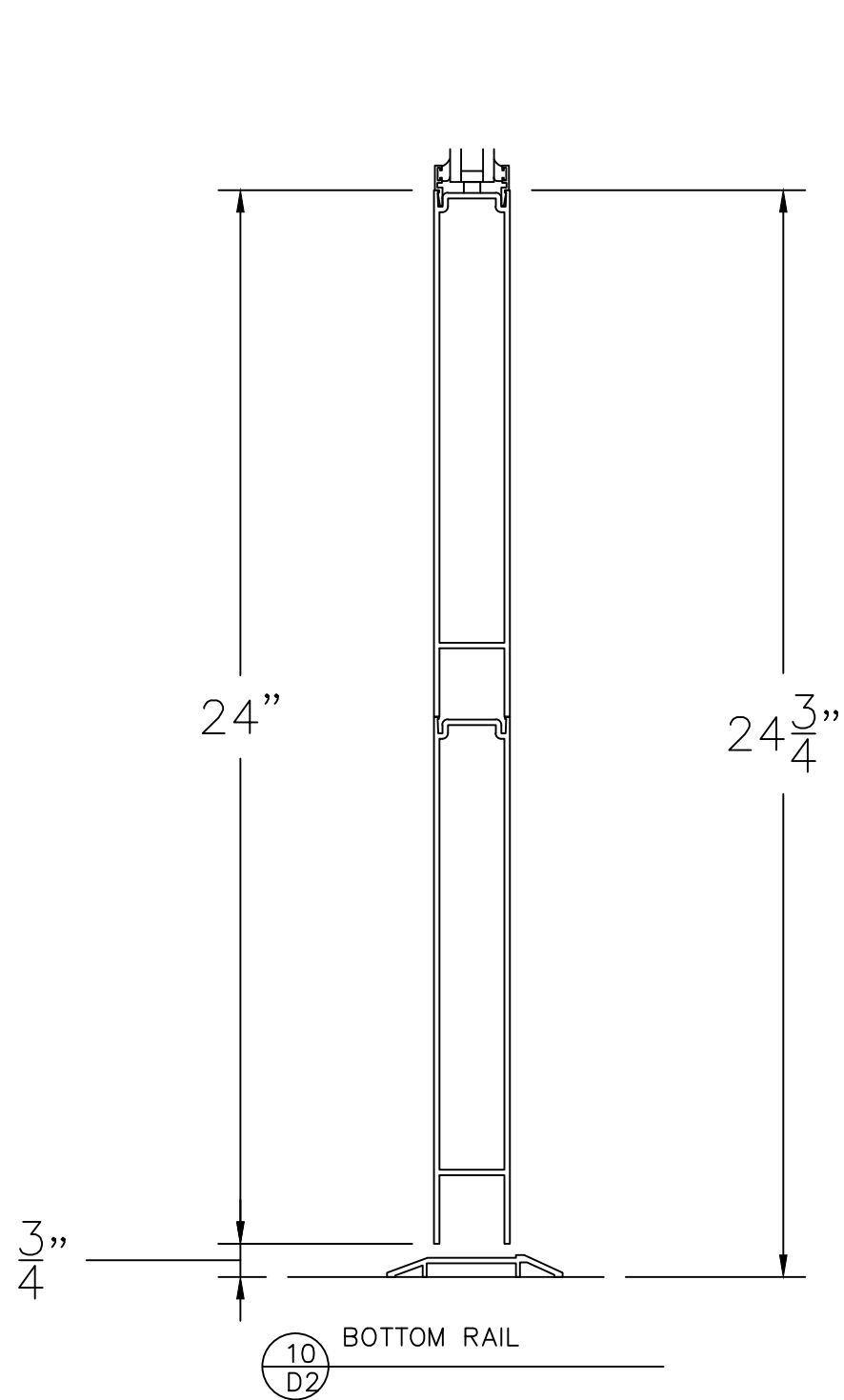

1101 W HAMMOND ROAD
 TRAVERSE CITY, MI 49686
 Phone: 231-941-0050
 Fax: 231-941-2251



Project
 THIRD STREET

Sheet
 Details

Drawn By
 Sam Braden

Approved By

Date Issued
 1-14-21

File No.
 C18253

Sheet No.
 D2



BAM-05R*
STANDARD
TAPE-ON

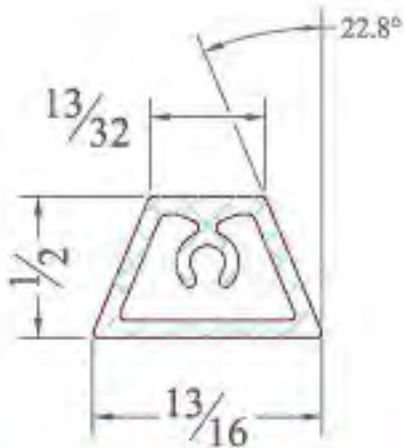

BAM-09

Laws and building and safety codes governing the design and use of Kawneer products, such as glazed entrance, window, and curtain wall products, vary widely. Kawneer does not control the selection of product configurations, operating hardware, or glazing materials, and assumes no responsibility therefor.

Kawneer reserves the right to change configuration without prior notice when deemed necessary for product improvement.
© 2015, Kawneer Company, Inc.

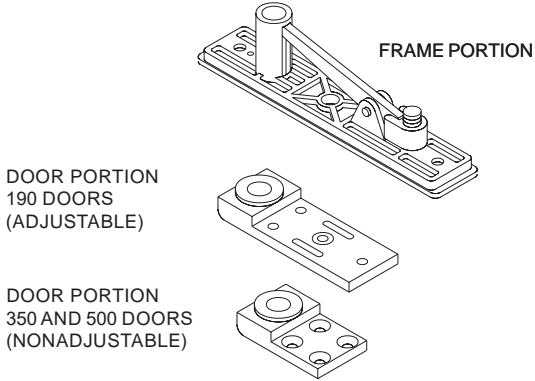

TOP CENTER PIVOT

Description: (Frame Portion) The “walking beam” frame pivot portion is cast aluminum with a hardened steel pivot pin. The pin is adjustable for additional extension through the transom bar/header. (Door Portion) Both door pivot portions are machined aluminum with oilite bronze self-lubricating bearings. All top center hung pivot parts are concealed.

Application: This pivot assembly is used in conjunction with center hung doors with floor closers. The adjustable portion for the 190 Narrow Stile Door provides for a one time only adjustment. Dimension 3" (76.2) long, 1-7/16" (36.5) wide, and 1/2" (12.7) at its thickest point. The 350 Medium Stile and 500 Wide Stile door pivot portion is nonadjustable. Dimensions 2-3/8" (60.3) long, 1-7/16" (36.5) wide, and 1/2" (12.7) at its thickest point.

Finish: The *frame portion* is natural cast aluminum with dress plate to match color of frame. The machined *door portion* is mill finish.

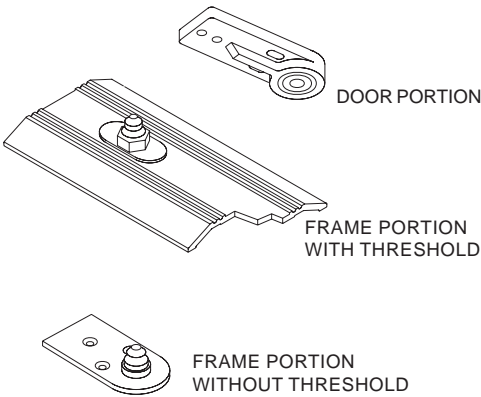

BOTTOM CENTER PIVOT

Description: The low profile center pivot for use with a threshold has an adjustable stainless steel pivot pin that is mounted and locked into the threshold. The center pivot for use without a threshold has a stainless steel pivot pin press fit into a stainless steel plate. The door portion is comprised of a roller bearing press fit into a cast aluminum pivot block.

Application: Both pivot portions, with or without threshold, are used on doors with concealed overhead closer control. On entrances with thresholds the pivot is anchored securely into the threshold. The frame portion is adjustable for proper door and frame clearance. The frame portion for use on doors without threshold is fastened directly to the floor. When no threshold is used, height adjustment is obtained by shimming the pivot block. The door pivot block is securely mounted to the bottom rail web.

Finish: Mill finish is standard for all bottom center pivot parts.

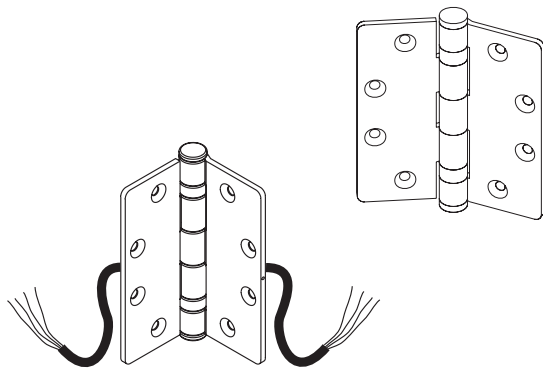

BUTT HINGE

Description: Commercial quality 300 series stainless steel hinge with leaves of five knuckle two ball bearing construction. The hinge barrel is enclosed with button tips and incorporates a non-removable pin. The hinge is a radius corner, standard template butt of 4-1/2" x 4" (114.3 x 101.6). The hinge leaf thickness is 0.134 inches (3.4). It is also available in electric transfer model.

Application: The butt hinge is fully mortised into the door hinge stile and frame hinge jamb. Reinforcing plates are used in both the frame jamb and hinge stile for secure screw anchorage available. The use of an intermediate butt (1-1/2" pair per leaf) is suggested for doors in high traffic areas or for doors over 7'-6" (2,286).

Finish: Hinges are powder painted to blend with door finish.

OPTIONAL EL version for access control applications.

CONTINUOUS HINGE

Description: Aluminum Continuous Geared Hinges provides long-lasting solutions for high-traffic and high-impact doors. The continuous geared hinge extends the full length of the door and frame. The two center gears form a rotating joint and the door weight is supported and cushioned by molded bearings evenly spaced along the entire length of the interlocking leaves.

Application: The continuous geared hinge is the hinge to suitable in high-traffic and high-impact areas. The hinge is surface applied to the frame and door stile. Fasteners are staggered at approximately 6" (152.4 mm) on center. Compatible with Standard Entrance, Heavy Wall®, Tuffline®, Flushline® and Insulclad® Thermal Entrances.

Finish: Available in #17 Clear, #29 Black, and #40 Dark Bronze anodized finishes. Painted finishes available on a custom basis.

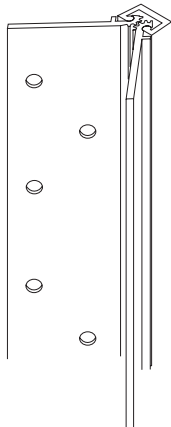

KAWNEER 1686 CONCEALED ROD EXIT DEVICE

Description: The Kawneer 1686 Concealed Rod exit device is an exclusive to Kawneer customers. This exit device is UL Listed, is Hurricane Impact tested and Florida Product Approved. This device has the feature of rod adjustment without panel removal. Depression of the touchbar on the interior retracts the concealed rods from the transom bar and the threshold, allowing egress from the building. Upon closing, the top rod is released and frees the bottom rod to engage the threshold. The door is now relocked. A quick single point "dogging" feature in the housing deactivates the device and permits unrestricted traffic flow. Vertical rods and latch mechanisms are concealed in the vertical door stile. A 1-5/32" diameter mortised 5-pin cylinder with trim is required.

Application: Designed for use on single or pairs of doors. It is suited for medium and high traffic areas. Available on 190, 350, and 500 Standard Entrances, 350/500 IR, 350/500 Heavy Wall®, 350/500 Heavy Wall® IR Entrances, and AA® 250/425 Thermal Entrances.

Dimensions: Center line of touchbar to bottom of door 40" (1,016); height 3-3/16" (81); Projection 2-3/4" (70); Projection when dogged 1-13/16" (46).

Finish: Clear and dark bronze.

Optional:

- 1686 MEL version for access control applications.
(Mechanical Hex Key and Cylinder dogging not available)
- Cylinder dogging in lieu of hex key dogging.
- Exterior lever trim handle.

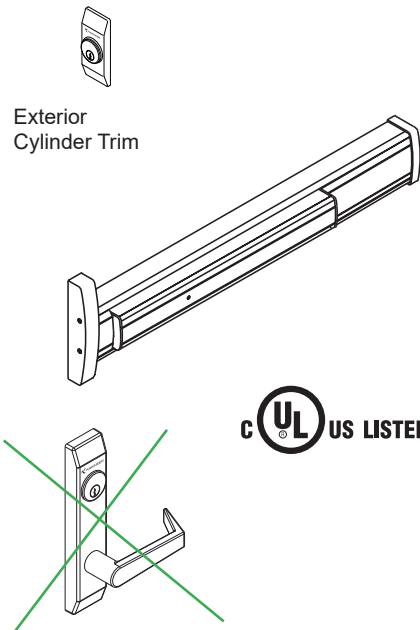

KAWNEER 1786 RIM EXIT DEVICE

Description: The Kawneer 1786 Rim exit device is an exclusive to Kawneer customers. This exit device is UL Listed. This device has the same basic features as the concealed vertical rod device above. Its difference is in the latching mechanism. A 5/8" throw latch bolt in the rim of the housing engages an aluminum jamb or removable mullion mounted strike. Depression of the touchbar on the interior retracts the latch bolt and permits egress from the building.

Application: Designed for use on single or pairs of doors. It is suited for medium and high traffic areas. Available on 190, 350, and 500 Standard Entrances, and 350/500 Heavy Wall® Entrances, and AA® 250/425 Thermal Entrances.

Dimensions: Center line of touchbar to bottom of door 40" (1,016); height 3-3/16" (81); Projection 2-3/4" (70); Projection when dogged 1-13/16" (46).

Finish: Clear and dark bronze.

Optional:

- 1786 MEL version for access control applications.
(Mechanical Hex Key and Cylinder dogging not available)
- Cylinder dogging in lieu of hex key dogging.
- Exterior lever trim handle.

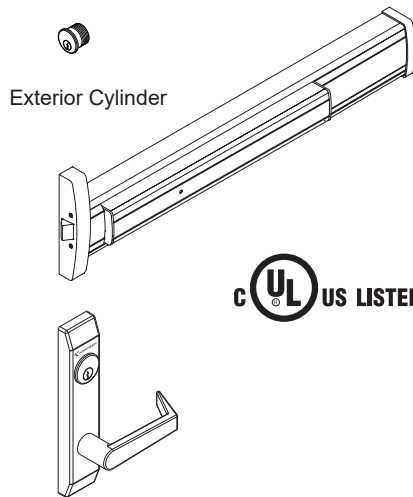

RM86 REMOVABLE MULLION

Description: This removable mullion is used with Kawneer 1786 Rim Exit Device.

Application: Designed for use with pairs of doors.

Finish: #17 Clear and #40 Bronze anodized.

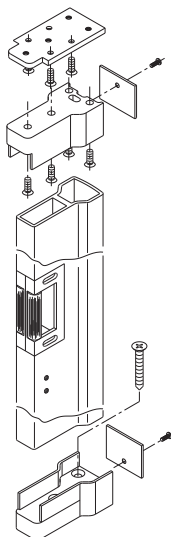

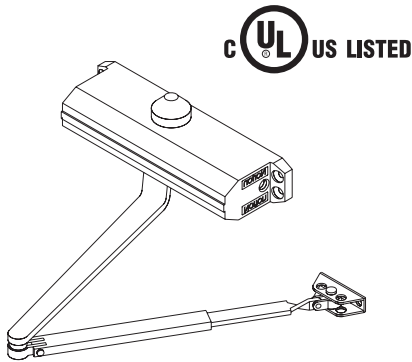

NORTON 1601

Description: The Norton 1601 is ANSI Grade 1 certified and is the standard offering in Kawneer's entrance package program. The compact closer design blends well with narrow aluminum door and frame sightlines. This versatile and rugged surface closer features hydraulic spring power controlled rack and pinion operation. The Norton 1601 offers adjustable spring sizes 1 - 6 and is ADA compliant for interior doors. The closer is non-handed, with separate adjustment for sweep and latch ranges are standard, an adjustment screw controls the back-check. Drop plates, corner brackets, and hold open arms are optional accessories.

Application: Closer mounting options are: Hinge (Pull) Side Mounting; the closer is mounted to the top door rail with the arm attached to the transom bar/header. Top Jamb (Push Side) Mounting; the closer is mounted to the transom bar/header. Parallel Arm (Push Side) Mounting; the closer is mounted to the top door rail with the arm and soffit plate attached to the transom bar/header. Parallel Arm mounting folds the closer arm parallel to the transom bar/header and minimizes the arm projection. The closer is suitable to areas of medium traffic volume.

Finish: Painted to match #17 finish and #40 finish.

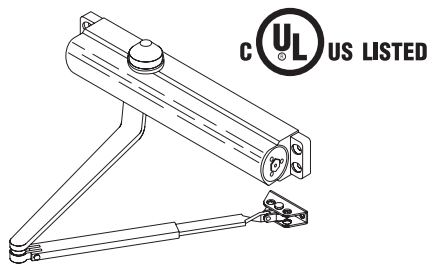

NORTON 8101

Description: A versatile, compact surface closer featuring spring and hydraulic powered rack and pinion operation. The closer incorporates field adjustable spring power and adjustable backcheck cushioning. The power can be adjusted by 50% by rotating the nut on the end of the closer to achieve an effective closer range of a size 2 through 6. The closer is non-handed with individual adjustable sweep speed and latch speed controls.

Application: See 1601 closer above.

Finish: Painted to match #17 finish or #40 finish.

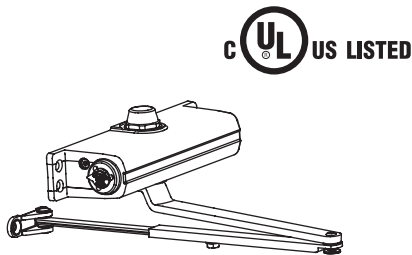

LCN 1260 SERIES

Description: A versatile closer incorporating spring and hydraulic powered rack and pinion operation with a 1-5 spring power adjustment. The 1261 is a one-piece cast iron closer to ensure reliability, extra leak protection, and longer closer life. An adjustable backcheck cushion is also standard. The 1261 is offered in a full range of arm options including heavy duty, extra duty, hold open, cushion and stop, and spring cushion. Adapter plates, cover, and other accessories are also offered. As with all LCN closers, a "peel and stick" template comes standard with each closer for faster closer installation.

Application: See 1601 closer above.

Finish: Painted to match #17 finish or #40 finish.

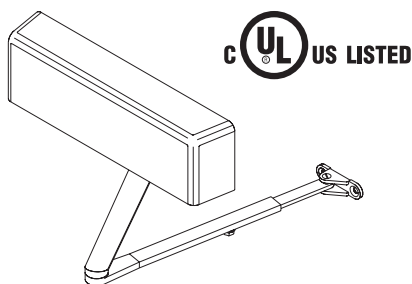

LCN 4040 XP

Description: A versatile closer incorporating spring and hydraulic powered rack and pinion operation. The closer spring power is field adjustable over a wide range for various power requirements. An adjustable back check cushions the opening swing prior to 90 degrees in all applications. Adapter plates, hold open arms, and other accessories are available.

Application: Closer mounting options are: Hinge (Pull) Side Mounting; the closer is mounted to the top door rail with the arm attached to the transom bar/header. Top Jamb (Push Side) Mounting; the closer is mounted to the transom bar/header. Parallel Arm (Push Side) Mounting; the closer is mounted to the top door rail with the arm and soffit plate attached to the transom bar/header. Parallel Arm mounting folds the closer arm parallel to the transom bar/header and minimizes the arm projection. The closer is adaptable to special applications and medium and heavy traffic volume.

Finish: Painted to match #17 finish, #29 finish or #40 finish.

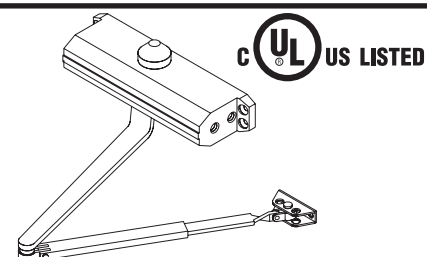

FALCON SC 60

Description: This economical and adjustable spring surface closer features hydraulic spring power controlled rack and pinion operation. The closer is non-handed, with separate adjustments for sweep, latch and back check. The adjustable power shoe allows total closer power adjustment of 15%. Plates, Parallel Arms and Hold-Open Arms are optional accessories.

Application: See 1601 closer above.

Finish: Painted to match #17 finish or #40 finish.

KAWNEER THRESHOLDS

Description/Application: Kawneer thresholds are factory fabricated and prepared for the appropriate hinging and locking hardware. They are extruded-mill finish aluminum and are engineered for maximum strength as an integral part of the door and frame. Threshold height from the finished floor is 1/2" (12.7 mm) except as noted.

Laws and building and safety codes governing the design and use of Kawneer products, such as glazed entrance, window, and curtain wall products, vary widely. Kawneer does not control the selection of product configurations, operating hardware, or glazing materials, and assumes no responsibility therefor.

Kawneer reserves the right to change configuration without prior notice when deemed necessary for product improvement.
© 2015, Kawneer Company, Inc.

CENTER HUNG

For Concealed Overhead Closer

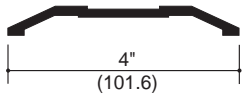

OFFSET PIVOT

For Overhead Closer

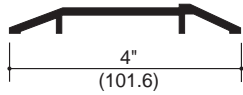

BUTT HUNG

For Overhead Closer

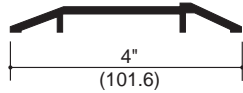
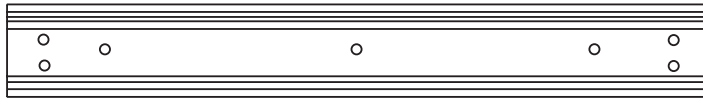

OPTIONAL

For Offset Pivot and Butt Hung Doors

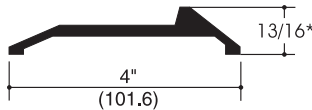
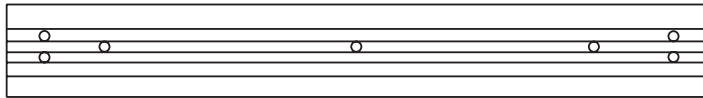

* On units that require ADA compliance the standard 1/2" high, offset pivot/butt hung threshold with bottom sweep will be supplied.

KAWNEER STANDARD "ARCHITECTS CLASSIC" HARDWARE

Description: Contemporary styled 1" (25.4) round bent bar is the basis for this hardware line. A 90 degree offset pull is available in two centerline dimensions: 9" (228.6) and 12" (304.8).

Application: For use with single or double acting doors.
A CP single bend push bar and a pull handle for single acting doors.
Two CP push bars or two pull handles mounted back to back for double acting doors.
Secure attachment is obtained by through the door mounting.

Finish: Hardware is available in:

- #14 Clear anodize
- #29 Black anodize
- #40 Dark Bronze anodize
- #44 Bronze - US10B oil rubbed
- #45 Stainless Steel - US32 polished
- #46 Stainless Steel - US32D dull
- #47 Bright Brass (PVD) - US3

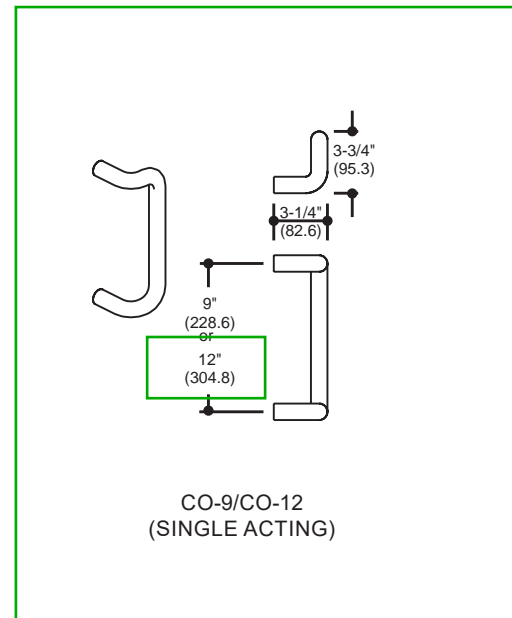
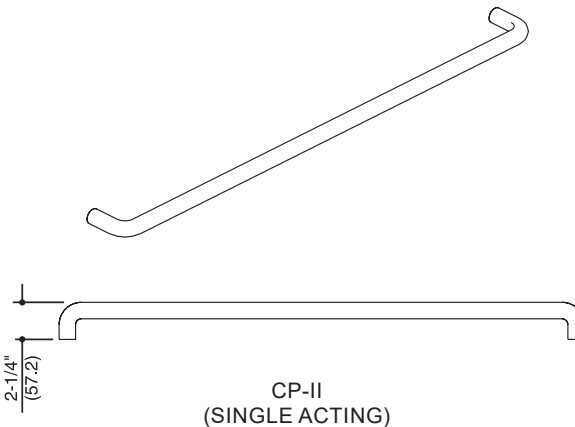
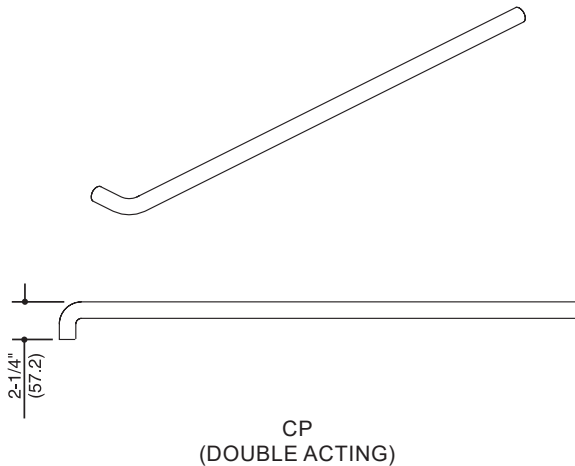

Laws and building and safety codes governing the design and use of Kawneer products, such as glazed entrance, window, and curtain wall products, vary widely. Kawneer does not control the selection of product configurations, operating hardware, or glazing materials, and assumes no responsibility therefor.

Kawneer reserves the right to change configuration without prior notice when deemed necessary for product improvement.
© 2015, Kawneer Company, Inc.



Nylon Brush Perimeter Seal or Sweep

D608



Perimeter & Door Sweep



Door Sweep Application only

Material

Aluminum alloy 6063, T5 temper
 Synthetic polymer: Polyamide
 Nylon brush

- Excellent abrasion resistance, flexibility and memory
- Moisture resistant
- Retains insecticides well
- Temperature range -70°F to 425°F
- Door Sweep application is Category H Smoke & Draft Control
- REACH and RoHS compliant
- Not effective against water penetration
- #6 x 3/4" stainless steel sheet metal screws furnished
- Screw holes slotted for adjustment

Finishes

D608A	Anodized Aluminum	Gray Brush
D608B	Gold	Black Brush
D608DKB	Dark Bronze	Black Brush

Options

FATT - Fast Attach Tape

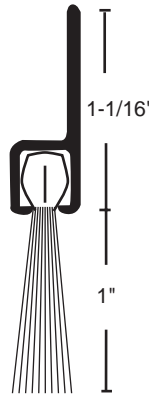

Project:

Submitted by:

Date:

Notes:

LCN®

1461 Series

Door controls



Fire Rated: Tested on fire door assemblies in accordance with Australian Standards, refer fire door manufacturer for specific approval details

The LCN 1461 Series is a non-handed surface mounted closer designed for maximum versatility. A wide choice of options, mounting accessories and ease of installation make this a fully universal closer.

The LCN 1461 Series has been designed to be used on aluminium, hollow metal or wood swinging commercial interior/exterior doors and is ideally suited for hospitals, nursing homes, hostels, shopping centres, commercial buildings, hotels, educational and institutional applications.

Features

- Universal, fully reversible, non-handed door closer
- Closer cylinder constructed of high strength cast iron for increased durability
- Tested to 2,000,000 cycles
- Fully adjustable 1-6 spring strength to suit door size and site conditions
- Factory set to strength 3
- Standard closer offers 3 installation options
 - Regular (pull side)
 - Top jamb (push side)
 - Parallel arm (push side)
- Independent adjustment valves for adjusting backcheck, closing and latching speeds
- All adjustment valves are concealed behind the cover to prevent tampering
- Joints in arms and shoe brackets adapt to uneven mounting surfaces
- Stick-on template for fast, accurate installation. Cuts installation time in half
- Closers installed according to LCN installation instructions require minimal periodic maintenance or adjustments
- Cush-N-Stop® function has a built in stop incorporated into the arm to prevent damage to the closer, door or frame in the event of an abrupt stop
- The 30 year warranty provides specifiers and users with assured quality and performance

Specification guide

Series	Function	Finish
LCN 1461 series LCN1461	Regular R Hold open HO Delayed action DA Cush-N-Stop® CNS Hold open Cush-N-Stop® CNS-HO	Aluminium ALUM

- Series
Select the desired series e.g. LCN 1461 series LCN1461
- Function
Select the required function LCN1461HO
- Finish
Select the desired finish e.g. Aluminium LCN1461HOALUM

Selection Chart

Strength	Exterior door	Interior door
1 - 2	NA	610mm - 864mm
3	610mm - 762mm	864mm - 965mm
4	762mm - 914mm	965mm - 1219mm
5	914mm - 1067mm	1219mm - 1372mm
6	1067mm - 1219mm	1372mm - 1524mm

Specifications

Door type	Timber or metal
Door size	External door 610mm - 1219mm Internal door 610mm - 1524mm
Applications	Regular - pull side mount Parallel arm - push side mount Top jamb - push side mount
Adjustment controls	Closing speed Latching speed Delayed action Backcheck
Strength	1-6 adjustable
Options	Hold open arm Cush-N-Stop® arm Hold open Cush-N-Stop® arm Adaptor plate Parallel arm drop plate Square metal cover
Finishes	Aluminium, satin stainless steel (optional cover only), polished stainless steel (optional cover only)
Warranty	30 year mechanical



Caution!

The LCN 1461 is designed for reduced opening force which when set to a 1 strength makes it suitable for use by people who are frail, aged or disabled. This closer can operate at between 14-20Nm from initial opening up to 90°

Where door closers are installed and adjusted to meet reduced opening force requirements, there may be insufficient power to reliably close and latch the door, depending on prevailing operating conditions

Note

In areas of high wind pressure and/or air conditioning pressures or doors located in exceptionally heavy traffic or oversized/heavy doors, the LCN 4041 series closers or LCN automatic door operators are recommended

Regulating controls

The LCN 1461 has independent regulators to control

Closing speed	Adjustment to increase or decrease the speed at which the door closes. This allows the appropriate momentum to close the door in a safe and secure manner. Closing speed adjustment operates from the maximum opening to 15°
Latching speed	The latching speed allows the door to close quietly and firmly. It can be adjusted to increase or decrease the speed at which the door finally closes. This assists the final stage of the closing cycle to help overcome stubborn latchbolts or air pressure conditions. The latching speed adjustment operates from 15° to closing
Backcheck	Adjustable hydraulic backcheck provides a cushioning effect when the door is forcibly thrown open to prevent damage to the closer, door and frame. The backcheck adjustment allows the level of resistance in the latter stage of opening to be set at the level required. Backcheck is effective from 75°. Backcheck is a requirement for all fire rated closers
Delayed action	Enables door closing action to be delayed for an adjustable period of time before resuming normal closing, allowing slow moving traffic to pass through. Delay action can be adjusted up to a delay time of approximately 1 minute. Operational zone of delay is between 180° to 75°
Power adjustment	Spring strength may be increased or decreased by turning the allen head screw located in the end of the door closer body

Functions

Regular	For applications where the door must fully close after each opening
Hold open	Suitable for doors where the door may need to be left in a hold open position. The hold open function can be set to hold open at a single point. Hold open closers can not be used on fire doors
Delayed action	Delayed action closers have an inbuilt adjustable control that delays the closing of the door, for up to approximately 1 minute
Cush-N-Stop®	Used predominantly on outward swinging doors in situations where it is not practical to fit a door stop. The Cush-N-Stop® function has a built in stop incorporated into the arm to prevent damage to the closer, door or frame in the event of an abrupt stop. It is recommended that metal door frames be reinforced where the arm attaches to the transom. Maximum door opening 100°
Hold open Cush-N-Stop®	Provides the same function as the Cush-N-Stop®, but has the added feature of a hold open function in the arm, which is engaged/disengaged by a tee handle. Maximum door opening 100°

Mounting details

Regular (pull side) mounting

Regular mounting has a maximum opening of 180°, with frame and trim permitting. The hold open arm allows the door to be set at one given hold open point up to the maximum opening. The reveal should not exceed 19mm for a regular arm or 13mm for a hold open arm. Top rail less than 64mm requires adaptor plate. Adaptor plate requires a 38mm minimum top rail. Clearance of 70mm behind door is required for 90° installation. Delayed action closer delays closing from 110° to 65° or 160° to 75° depending on templating

Maximum opening 110°

A = 169mm

B = 286mm

Maximum opening 180°

A = 76mm

B = 191mm

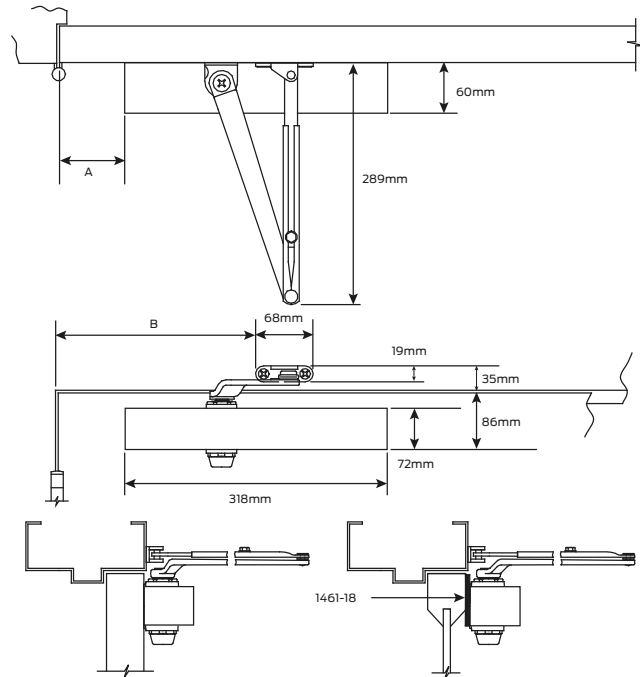

Top jamb (push side) mounting

Top jamb mounting has a maximum opening of 180°. The hold open arm allows the door to be set at a given hold open point up to the maximum opening. A reveal of 64mm for hold open arms and 89mm for regular arms allows a 180° opening. Top rail less than 48mm requires adaptor plate. Adaptor plate requires a 70mm minimum top rail. For situations where the head frame is less than 44mm or a flush ceiling condition exists with a 51mm head frame, an adaptor plate is required. Adaptor plate requires a 32mm minimum head frame. Delayed action closer delays closing from 110° to 75° or 180° to 95° depending on templating.

Maximum opening 110°

A = 169mm

B = 286mm

Maximum opening 180°

A = 76mm

B = 191mm

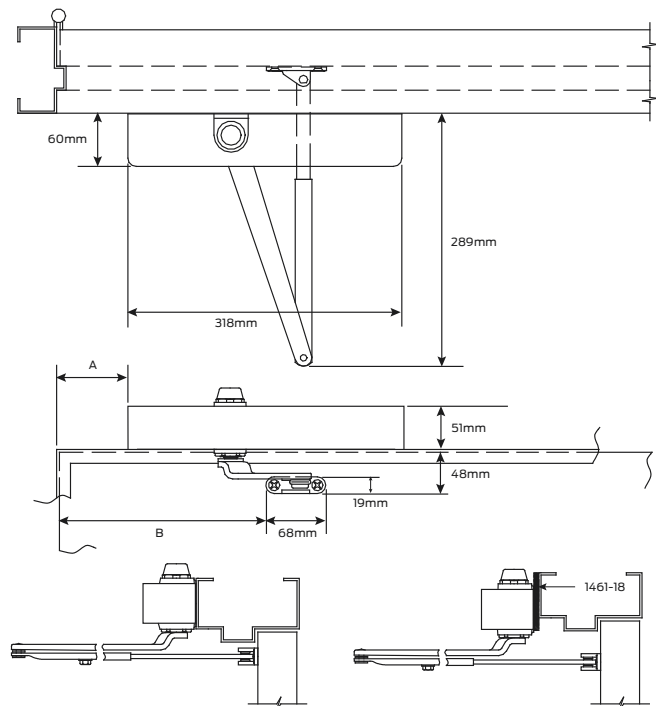

Mounting details

Parallel arm (push side) mounting

Parallel arm mounting has a maximum opening of 180°. The hold open arm allows the door to be set at one given hold open point up to the maximum opening. Clearance for the PA shoe is 102mm from door face. Top rail less than 108mm measured from the stop requires drop plate. The drop plate requires a 44mm minimum top rail. Minimum stop width is 25mm. Blade stop clearance requires 13mm blade stop spacer. Delayed action closer delays closing from maximum opening to approximately 75°. When installing closers in parallel arm configuration, strength may be needed to be adjusted upwards to compensate for power reduction

Maximum opening 100°

A = 108mm

B = 235mm

Maximum opening 180°

A = 44mm

B = 171mm

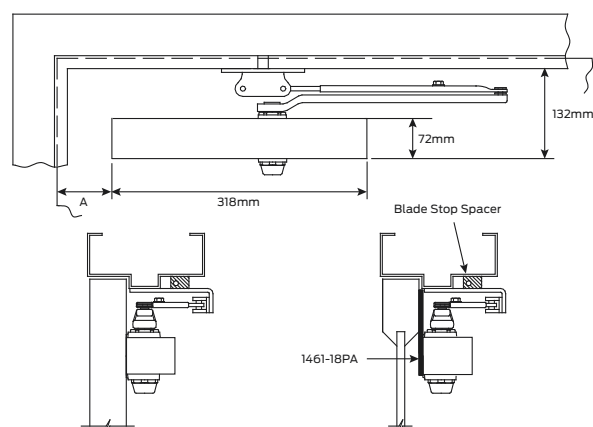
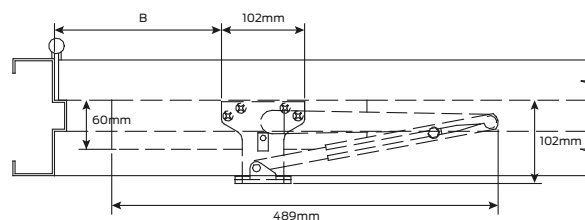

Cush-N-Stop® (push side) mounting

Cush arms can be templated for the following maximum opening/hold open points:

1. 85° - A = 60mm & B = 243mm
2. 90° - A = 41mm & B = 230mm
3. 100° - A = 16mm & B = 205mm

Clearance for the cush shoe is 140mm from door face. Top rail less than 108mm measured from the stop requires drop plate. The drop plate requires a 44mm minimum top rail

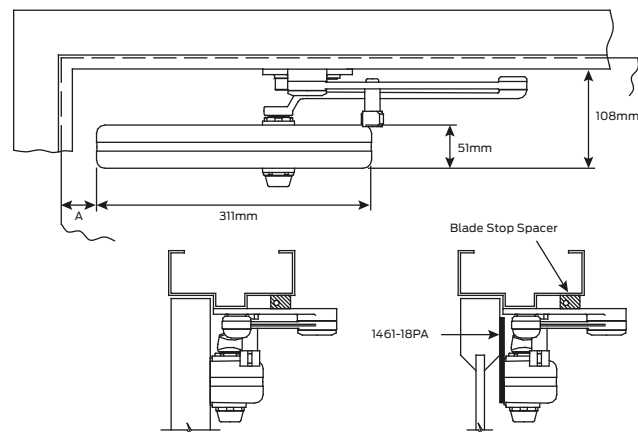
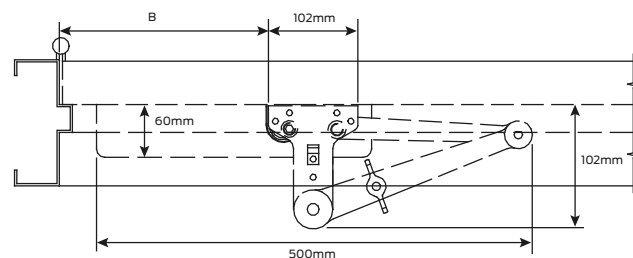

1461 Series accessories

Regular arm 1460-3077

Standard, non-handed arm mounts hinge side or top jamb. For parallel arm mounting, a PA shoe is also required
Finish: Aluminium

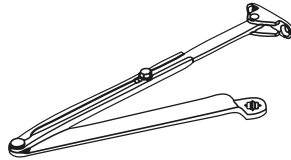

Hold open 1460-3049

Non-handed, hold open arm mounts hinge side or top jamb. For parallel arm mounting, a PA Shoe is also required. Hold open adjustable at shoe
Finish: Aluminium

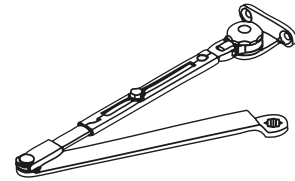

Cush-N-Stop[®] arm 1460-3077CNS

Non-handed parallel arm features solid forged steel main arm and forearm, with stop in soffit shoe
Finish: Aluminium

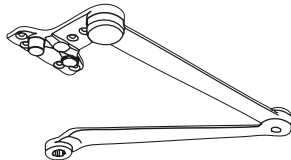

Hold open Cush-N-Stop[®] arm 1460-3049CNS

Non-handed arm, provides hold open function with templated stop/hold open points. Handle controls hold open function
Finish: Aluminium

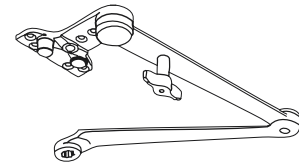

Metal cover 1460-MC

Non-handed cover, providing complete enclosure of closer body
Finishes: Polished stainless steel, satin stainless steel

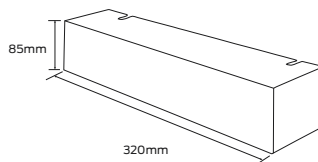

Blade stop spacer 1460-61

Lowers parallel arm shoe to clear 13mm blade stop

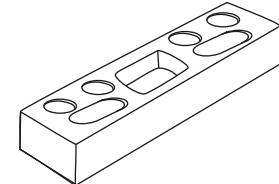

Drop plate 1460-18PAFC

Mounting plate required for parallel arm mounting configuration where top rail is less than 114mm, measured from the stop. A drop plate requires a 44mm minimum top rail

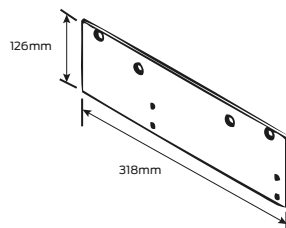

Adaptor plate 1460-18FC

Mounting plate required top jamb mounting where head frame is less than 60mm or a flush ceiling condition exists

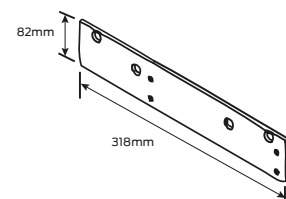

PA shoe 1460-62PA

Required for parallel arm mounting configurations
Finish: Aluminium

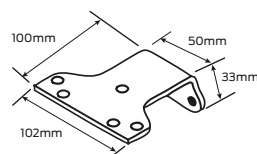



Proposed Front Elevation Light Fixture

Description

12" [305mm] wide coverage, 7/8" [22mm] deep profiled panels featuring one, two, or three asymmetrical ribs. These profiles have a unique interlocking side joint that incorporates a 16 gage [1.52mm] clip that provides concealed fastening and allows for thermal movement in non-overlapping conditions. This joint also functions to minimize moisture intrusion.

All Concept Series wall panels can be installed in a variety of horizontal or vertical rainscreen applications to form a complete wall system. Systems may vary from an uninsulated screen wall to a system utilizing MetalWrap®, an insulated composite backup panel system that provides Advanced Thermal and Moisture Protection (ATMP®). Contact your local CENTRIA sales person for more information regarding the performance of CENTRIA's rainscreens. This wall panel system has three attachment clip options. Contact CENTRIA for more information.

Notes

- A. For information on special applications, contact your local CENTRIA Representative.
- B. All Concept Series panels may be used on walls and soffits but not roofs.
- C. Panel length tolerance is + or - 1/4" [6mm].
- D. For protective coatings - see CENTRIA Color Chart or visit www.CENTRIA.com.
- E. Oil canning within mill tolerances will not be cause for rejection.

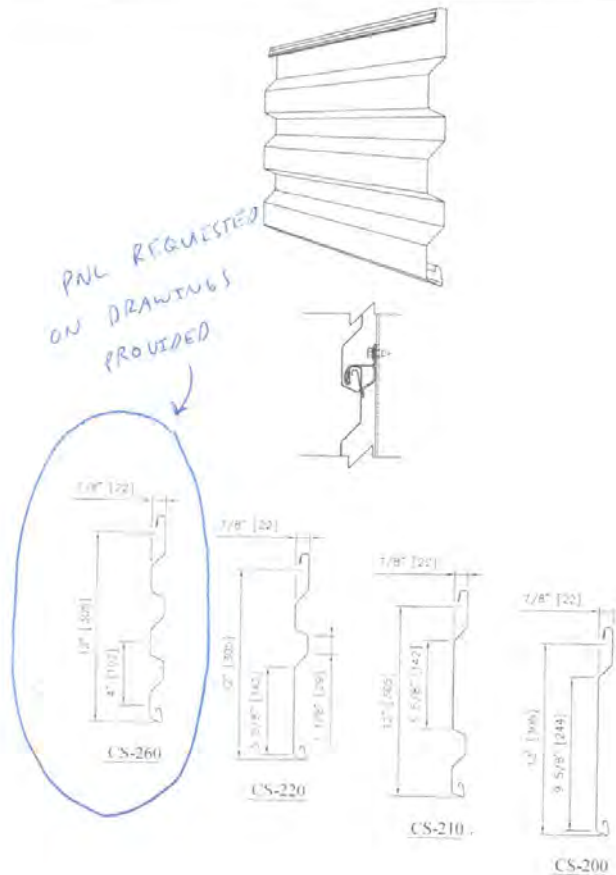

General Design Options

	GALVANIZED ¹ (G90)	STAINLESS STEEL ¹ (304)	ALUMINUM ¹ (3003-H14)	ZINC ¹ (PRE-WEATHERED)
PANEL DEPTH	7/8" [22mm]	7/8" [22mm]	7/8" [22mm]	7/8" [22mm]
PANEL COVERAGE	12" [305mm]	12" [305mm]	12" [305mm]	12" [305mm]
SIDE LAP	Interlocking	Interlocking	Interlocking	Interlocking
END LAPS	(See standard detail) Shop or field notch 2" [51mm] for 22 [.76mm] and 24 [.60mm] gages only. Flash or extrusion for all gages	(See standard detail) Shop or field notch 2" [51mm] for 22 [.76mm] and 24 [.60mm] gages only. Flash for all gages	(See standard detail) Shop or field notch 2" [51mm] for .032" [.81mm] Flash or extrusion for all thicknesses	(See standard detail) Flashing
GAGES (STANDARD)	20 [.91mm], 22 [.76mm]	20 [.91mm], 22 [.76mm]	.040" [1.02mm], .050" [1.27mm]	1mm [.039"]
GAGES (OPTIONAL)	18 [1.19mm], 24 [.60mm] CS-260 only	24 [.60mm] CS-260 only	.032" [.81mm] CS-260 only	Contact CENTRIA
STANDARD LENGTH	5 [1.52m] - 30 ft. [9.14m]	5 [1.52m] - 30 ft. [9.14m]	5 [1.52m] - 20 ft. [6.10m]	5 [1.52m] - 10 ft. [3.05m] ³
TEXTURE (STANDARD)	Smooth	Smooth	Smooth	Smooth - Directional
TEXTURE (OPTIONAL)	Embossed ² (20 [.91mm] - 24 [.60mm] gage only)	Embossed ²	Embossed ² (.032" [.81mm] only)	N/A
FINISHES	See CENTRIA Color Chart	#4 Brushed	See CENTRIA Color Chart	See Jarden Color Chart

1. Alternate base material, panel lengths and gages may also be available. Contact CENTRIA.
 2. Embossing is non-directional.
 3. Maximum Zinc Panel lengths are 10' [3.048m] for vertical and 20' [6.0m] for horizontal panels.
 * Patent No.: US D538,948; D527,834



ATAS International, Inc.

Sustainable Building Envelope Technology

THIS IS THE PANEL WE INTEND TO SUPPLY IN LIEU OF THE CONTRA PNL

SPECIFICATION DATA SHEET

1. PRODUCT NAME

RIGID WALL II™ MFN

2. MANUFACTURER

ATAS INTERNATIONAL, INC.
 Website: www.atas.com
 Email: info@atas.com
 Corporate Headquarters:
 Allentown, PA 18106
 Phone: (800) 468-1441
 Western Facility:
 Mesa, AZ 85204
 Phone: (480) 558-7210

3. PRODUCT DESCRIPTION

Basic Uses:

Rigid Wall II profiles are available in widths of 8", 12", or 16". The panels are 1 5/8" deep and provide dramatic shadow lines with their 1 3/8" wide ribs. The panels utilize the Wind-Lok™ concealed fastening system and offer uninterrupted vertical or horizontal sight lines.

Composition & Materials:

Standard Offerings: Rigid Wall II panels are roll-formed from .032, .040 and .050 aluminum; 24, 22 gauge metallic coated steel; and 24 gauge 55% Al-Zn alloy coated steel with acrylic coating.

Special Offerings: 18 and 20 gauge metallic coated steel; 1.0 mm zinc; and 18, 20, and 22 gauge Al-Zn alloy coated steel with acrylic coating.

Sizes:

Rigid Wall II panels have an 8", 12", or 16" wide nominal coverage. Panel lengths are cut to customer specifications, with a minimum of 6'-0" and maximum to transportation limitations and/or product and project design considerations.

Colors & Finishes:

Available in a wide variety of material and color options, with a 70% PVDF finish. (Request color chart or chips). An anodized finish is available in Clear Satin or Dark Bronze. Texture may be smooth or embossed. Panels can be solid or perforated.

4. TECHNICAL DATA

70% PVDF finishes tested by paint supplier for:

- Dry Film Thickness: ASTM D 1005, ASTM D 1400, ASTM D 4138 or ASTM D 5796
- Specular Gloss: ASTM D 523
- Pencil Hardness: ASTM D 3363
- T-Bend Flexibility: ASTM D 4145
- Mandrel Bend Flexibility: ASTM D 522
- Impact Resistance: ASTM D 2794
- Adhesion: ASTM D 3359
- Water Immersion Resistance: ASTM D 870
- Abrasion Resistance: ASTM D 968
- Acid Resistance: ASTM D 1308

- Acid Rain Resistance (Kesternich): ASTM G 87 or DIN 50018
- Salt Spray: ASTM B 117
- Cyclic Salt Spray: ASTM D 5894 and ASTM D 5487
- Humidity Resistance: ASTM D 2247
- Accelerated Weathering: ASTM D 822 and ASTM G 23, ASTM G 151 or ASTM G 153
- Color Retention, Florida Exposure: ASTM D 2244
- Chalking Resistance - ASTM D 4214
- Cleveland Condensing Cabinet: ASTM D 4585
- Cure Test, MEK Resistance: ASTM D 5402
- Alkali Resistance, Sodium Hydroxide: ASTM D 1308, Procedure 7.2
- Organic coatings meet requirements of AAMA 2605 when applied to aluminum.

Panel testing/ratings:

- UL Fire resistance rating design numbers: See www.ul.com, File R12113, or contact ATAS for current listing. ASTM E 84 Flame Spread
- Galvanized Steel: ASTM A 653
- 55% Al-Zn alloy Coated Steel with acrylic coating: ASTM A 792
- Aluminum: ASTM B 209
- Coil Coating: ASTM A 755
- Load Tables available upon request.

5. INSTALLATION

Installation manuals and hands-on training via seminars are available through ATAS. Visit www.atas.com for more information.

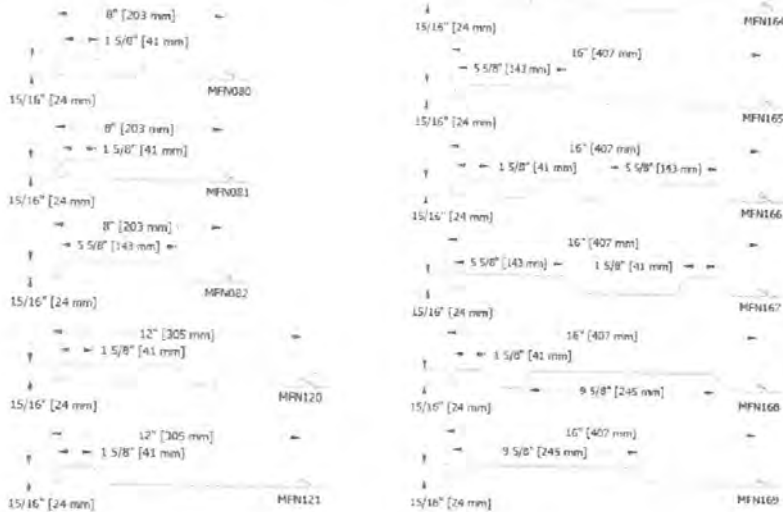

MOTOR SPECIFICATIONS:

1/2 HP motor to include a TENV motor, reversing magnetic controller in NEMA 1 enclosure, planetary gearbox for drive reduction, electric brake and an auxiliary chain operator. Includes UL listed thermal overload protection, rotary limit switches, safety edge circuit and transformer with 24 volt control secondary, and delay on reverse. Pre-wired to a terminal block using color coding of the wires to facilitate troubleshooting.

CURRENT CHARACTERISTICS:

120 V 1 PH 60 HZ 2.6 FLA

Electrical current must be verified in writing before job is released for manufacture; current verified and found correct. Operator bracket bracing required; unless operator is wall mounted.
Signed:

ELECTRICAL EQUIPMENT LIST:

- 1 - Pair of photo eyes, NEMA 4X
- 1 - Three button push button station 'OPEN-CLOSE-STOP' in NEMA 1 enclosure, surface mounted.

BOTTOM BAR LOCKING:

None

QUANTITY & MARK:

(1) A

MATERIAL & FINISH:

- Front slat** - Galvanized steel with Galvalux™ coating system. Finish color: Gray
- Back slat** - Galvanized steel with Galvalux™ coating system. Finish color: Gray
- Bottom Bar** - Extruded aluminum, mill finish
- Guides** - Structural steel, Gray polyester powder coating
- Hood** - Galvanized steel with Galvalux™ coating system. Finish color: Gray
- Plain Steel** - Powder coated gray

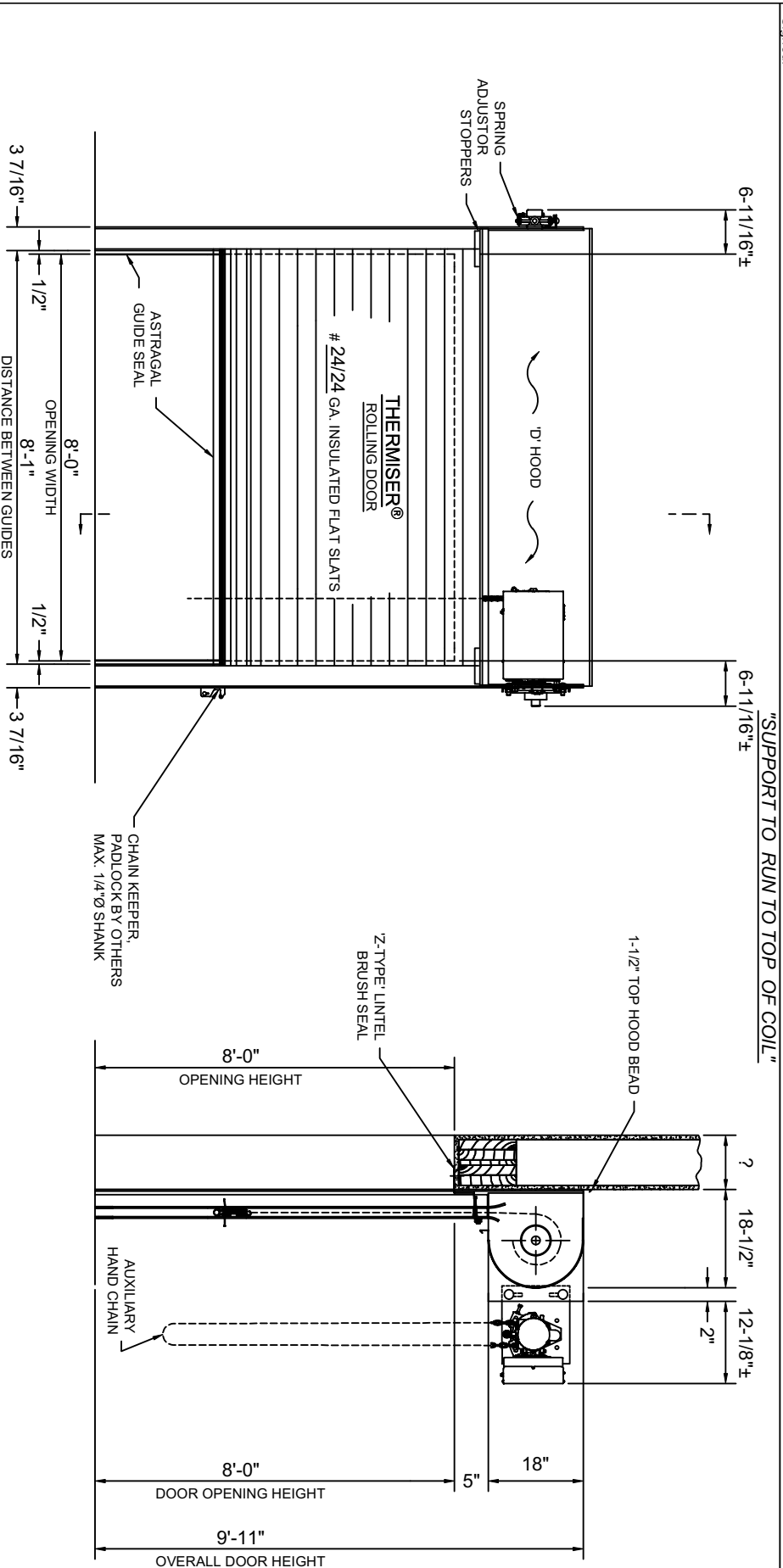

12-10-2020	PRODUCT CODE:
MTR. STD	MFW 6F 44GP

ELEVATION (COIL SIDE) AND SECTION VIEW
See drawing # E 01516319 001 B for guide detail.

MODEL #:	JOB #:
ESD20	E 01516319 001 A

#	REVISION	DATE	BY
--	ORIGINAL DRAWING	12/22/20	R481

CORNELL
Innovative door solutions.

JOB: MGH MOTOR OPERATED ROLLING DOOR
MIDTOWN DETROIT, MI

AGENT: RAYNOR OVHD DOOR CORP
CONTRACTOR:
ARCHITECT:

NOTE: Wall construction detail shown is for illustrative purposes only, does not imply compliance with building requirements, and must meet architectural specifications to properly support product. Products designed with wind load requirements must be properly fastened to structural members as specified in order to avoid catastrophic failure. Wall construction and closure installation shall be in accordance with the local authority having jurisdiction requirements.

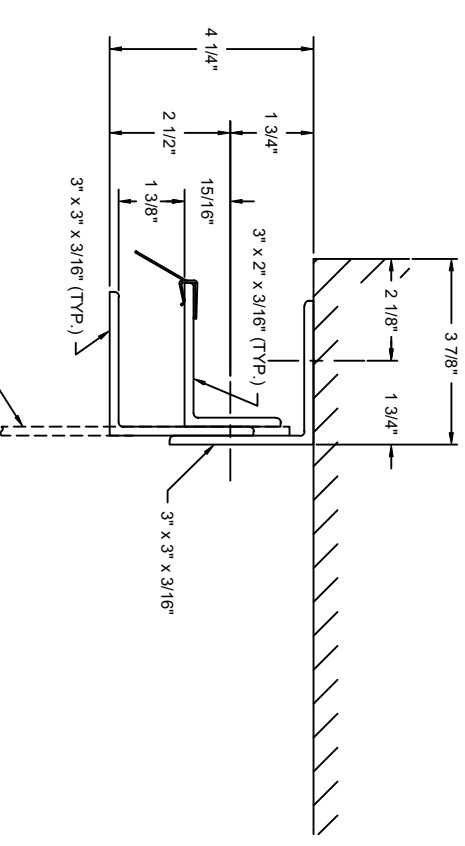
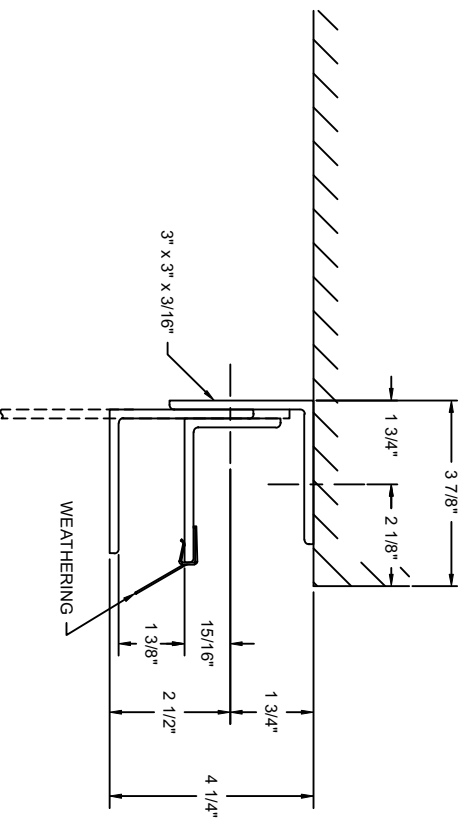

GA0415 - 4 1/4"

GA0415 - 4 1/4"

WALL FASTENERS:

- AT 36" ON CENTER
- Ø3/8" x 2"
- HEX HEAD LAG SCREW

ASSEMBLY FASTENERS:

- AT 36" ON CENTER
- Ø3/8-16 x 1 1/2" HEX HEAD CAP SCREW, GR. 5
- HEX HEAD NUT, GR. 5
- HARDENED FLAT WASHERS

WALL FASTENERS:

- AT 36" ON CENTER
- Ø3/8" x 2"
- HEX HEAD LAG SCREW

ASSEMBLY FASTENERS:

- AT 36" ON CENTER
- Ø3/8-16 x 1 1/2" HEX HEAD CAP SCREW, GR. 5
- HEX HEAD NUT, GR. 5
- HARDENED FLAT WASHERS

BOTTOM BAR / SLAT DETAIL

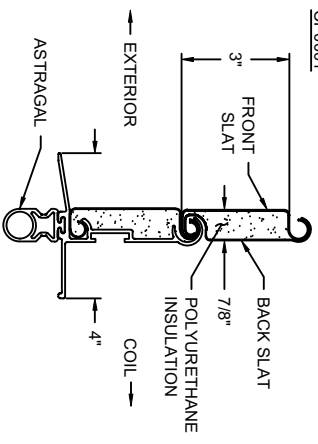

PLAN OF OPENING

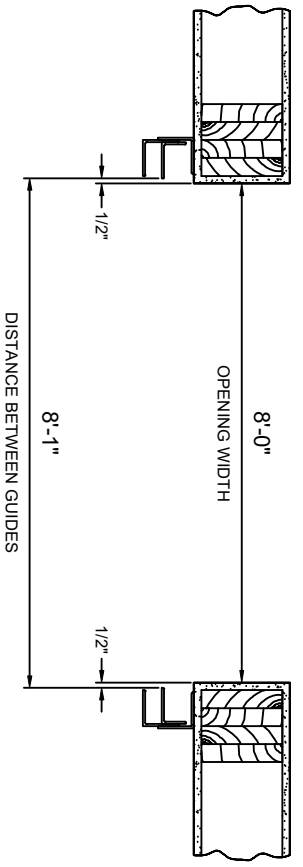

INSTALLERS NOTE:

MAINTAINING FACTORY SET GUIDE GAPS IS CRITICAL TO THE PROPER OPERATION OF THE DOOR AND ITS ABILITY TO WITHSTAND THE DESIGNED WINDLOAD!

ENDLOCK DETAIL

CP1443 MOLDED NYLON ENDLOCK ON ALTERNATING SLATS WITH 2 x 1/4" RIVETS

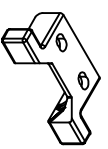

CP1443

10-09-2018	PRODUCT CODE:	TD7_425	MFW 6F 44GP
---	ORIGINAL DRAWING	12/22/20	R48.1
#	REVISION	DATE	BY



JOB: MIDTOWN DETROIT, MI
 INSULATED SERVICE DOOR GUIDE ASSEMBLY, 4-1/4" PACKOFF

MODEL #:	ESD20	JOB #:	E 01516319 001 B
AGENT:	RAYNOR OVHD DOOR CORP		
CONTRACTOR:			
ARCHITECT:			

WALL MOUNTED FIXTURE.

Lumark

DESCRIPTION

The patented Lumark Crosstour™ LED Wall Pack Series of luminaires provides an architectural style with super bright, energy efficient LEDs. The low-profile, rugged die-cast aluminum construction, universal back box, stainless steel hardware along with a sealed and gasketed optical compartment make the Crosstour impervious to contaminants. The Crosstour wall luminaire is ideal for wall/surface, inverted mount for façade/canopy illumination, post/bollard, site lighting, floodlight and low level pathway illumination including stairs. Typical applications include building entrances, multi-use facilities, apartment buildings, institutions, schools, stairways and loading docks test.

SPECIFICATION FEATURES

Construction

Slim, low-profile LED design with rugged one-piece, die-cast aluminum hinged removable door and back box. Matching housing styles incorporate both a small and medium design. The small housing is available in 12W, 18W and 26W. The medium housing is available in the 38W model. Patented secure lock hinge feature allows for safe and easy tool-less electrical connections with the supplied push-in connectors. Back box includes three half-inch, NPT threaded conduit entry points. The universal back box supports both the small and medium forms and mounts to standard 3-1/2" to 4" round and octagonal, 4" square, single gang and masonry junction boxes. Key hole gasket allows for adaptation to junction box or wall. External fin design extracts heat from the fixture surface. One-piece silicone gasket seals door and back box. Minimum 5" wide pole for site lighting application. Not recommended for car wash applications.

Optical

Silicone sealed optical LED chamber incorporates a custom engineered mirrored anodized reflector providing high-efficiency illumination. Optical assembly includes impact-resistant tempered glass and meets IESNA requirements for full cutoff compliance. Available in seven lumen packages; 5000K, 4000K and 3000K CCT.

Electrical

LED driver is mounted to the die-cast housing for optimal heat sinking. LED thermal management system incorporates both conduction and natural convection to transfer heat rapidly away from the LED source. 12W, 18W, 26W and 38W series operate in -40°C to 40°C [-40°F to 104°F]. High ambient 50°C models available. Crosstour luminaires maintain greater than 89% of initial light output after 72,000 hours of operation. Three half-inch NPT threaded conduit entry points allow for thru-branch wiring. Back box is an authorized

electrical wiring compartment. Integral LED electronic driver incorporates surge protection. 120-277V 50/60Hz or 347V 60Hz models.

Finish

Crosstour is protected with a Super durable TGIC carbon bronze or summit white polyester powder coat paint. Super durable TGIC powder coat paint finishes withstand extreme climate conditions while providing optimal color and gloss retention of the installed life.

Warranty

Five-year warranty.

Catalog #		Type	
Project		Date	
Comments			
Prepared by			



**XTOR
CROSSTOUR LED**

- APPLICATIONS:**
 WALL / SURFACE
 POST / BOLLARD
 LOW LEVEL
 FLOODLIGHT
 INVERTED
 SITE LIGHTING

DIMENSIONS

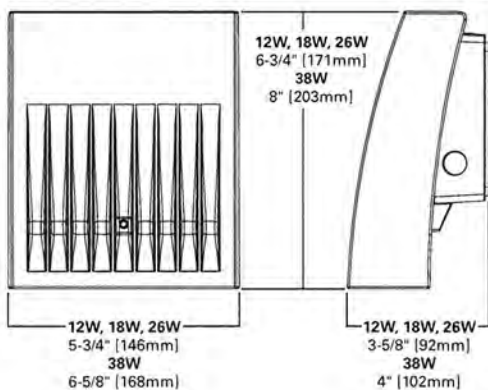

ESCUTCHEON PLATES

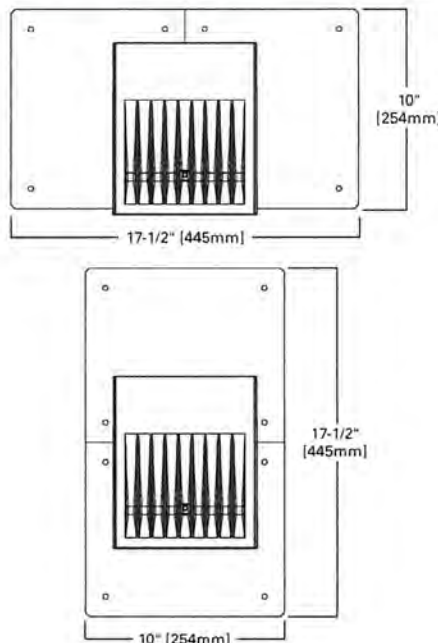

CERTIFICATION DATA

- UL/cUL Wet Location Listed
- LM79 / LM80 Compliant
- ROHS Compliant
- ADA Compliant
- NOM Compliant Models
- IP66 Ingressed Protection Rated
- Title 24 Compliant
- DesignLights Consortium® Qualified*

TECHNICAL DATA

- 40°C Maximum Ambient Temperature
- External Supply Wiring 90°C Minimum

EPA

- Effective Projected Area (Sq. Ft.):
 XTOR1B, XTOR2B, XTOR3B=0.34
 XTOR4B=0.45

SHIPPING DATA:

- Approximate Net Weight:
 3.7 – 5.25 lbs. [1.7 – 2.4 kgs.]

POWER AND LUMENS BY FIXTURE MODEL

LED Information	XTOR1B	XTOR1B-W	XTOR1B-Y	XTOR2B	XTOR2B-W	XTOR2B-Y	XTOR3B	XTOR3B-W	XTOR3B-Y	XTOR4B	XTOR4B-W	XTOR4B-Y
Delivered Lumens (Wall Mount)	1,418	1,396	1,327	2,135	2,103	1,997	2,751	2,710	2,575	4,269	4,205	3,995
Delivered Lumens (With Flood Accessory Kit) ¹	1,005	990	940	1,495	1,472	1,399	2,099	2,068	1,965	3,168	3,121	2,965
B.U.G. Rating ²	B1-U0-G0	B1-U0-G0	B1-U0-G0	B1-U0-G0	B1-U0-G0	B1-U0-G0	B1-U0-G0	B1-U0-G0	B1-U0-G0	B2-U0-G0	B2-U0-G0	B2-U0-G0
CCT (Kelvin)	5,000	4,000	3,000	5,000	4,000	3,000	5,000	4,000	3,000	5,000	4,000	3,000
CRI (Color Rendering Index)	70	70	70	70	70	70	70	70	70	70	70	70
Power Consumption (Watts)	12W	12W	12W	18W	18W	18W	26W	26W	26W	38W	38W	38W

NOTES: 1 Includes shield and visor. 2 B.U.G. Rating does not apply to floodlighting.

LUMEN MAINTENANCE

Ambient Temperature	TM-21 Lumen Maintenance (72,000 Hours)	Theoretical L70 (Hours)
XTOR1B Model		
25°C	> 90%	255,000
40°C	> 89%	234,000
50°C	> 88%	215,000
XTOR2B Model		
25°C	> 89%	240,000
40°C	> 88%	212,000
50°C	> 87%	196,000
XTOR3B Model		
25°C	> 89%	240,000
40°C	> 88%	212,000
50°C	> 87%	196,000
XTOR4B Model		
25°C	> 89%	222,000
40°C	> 87%	198,000
50°C	> 87%	184,000

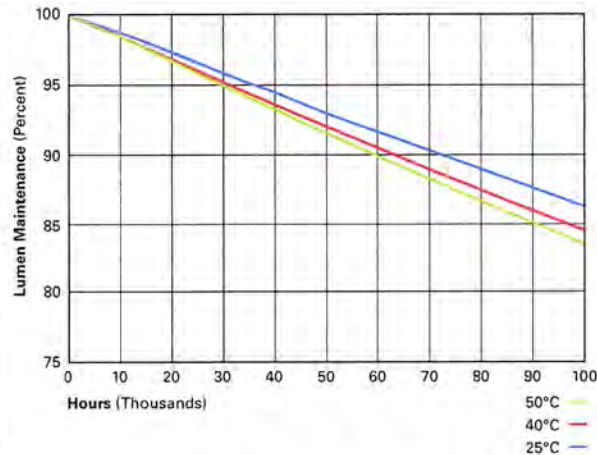

CURRENT DRAW

Voltage	Model Series			
	XTOR1B	XTOR2B	XTOR3B	XTOR4B
120V	0.103A	0.15A	0.22A	0.34A
208V	0.060A	0.09A	0.13A	0.17A
240V	0.053A	0.08A	0.11A	0.17A
277V	0.048A	0.07A	0.10A	0.15A
347V	0.039A	0.06A	0.082A	0.12A

ORDERING INFORMATION

Sample Number: XTOR2B-W-WT-PC1

Series ¹	LED Kelvin Color	Housing Color	Options (Add as Suffix)	Accessories (Order Separately)
XTOR1B=Small Door, 12W XTOR2B=Small Door, 18W XTOR3B=Small Door, 26W XTOR4B=Medium Door, 38W	[Blank]=Bright White (Standard), 5000K W=Neutral White, 4000K Y=Warm White, 3000K	[Blank]=Carbon Bronze (Standard) WT=Summit White BK=Black BZ=Bronze AP=Grey GM=Graphite Metallic DP=Dark Platinum	PC1=Photocontrol 120V ² PC2=Photocontrol 208-277V ^{2,3} 347V=347V ⁴ HA=50°C High Ambient ⁴	WG/XTOR=Wire Guard ⁵ XTORFLD-KNC=Knuckle Floodlight Kit ⁶ XTORFLD-TRN=Trunnion Floodlight Kit ⁶ XTORFLD-KNC-WT=Knuckle Floodlight Kit, Summit White ⁶ XTORFLD-TRN-WT=Trunnion Floodlight Kit, Summit White ⁶ EWP/XTOR=Escutcheon Wall Plate, Carbon Bronze EWP/XTOR-WT=Escutcheon Wall Plate, Summit White

NOTES:

1. DesignLights Consortium® Qualified and classified for both DLC Standard and DLC Premium, refer to www.designlights.org for details.
2. Photocontrols are factory installed.
3. Order PC2 for 347V models.
4. Thru-branch wiring not available with HA option or with 347V. XTOR3B not available with HA and 347V or 120V combination.
5. Wire guard for wall/surface mount. Not for use with floodlight kit accessory.
6. Floodlight kit accessory supplied with knuckle (KNC) or trunnion (TRN) base, small and large top visors and small and large impact shields.

STOCK ORDERING INFORMATION

12W Series	18W Series	26W Series	38W Series
XTOR1B=12W, 5000K, Carbon Bronze	XTOR2B=18W, 5000K, Carbon Bronze	XTOR3B=26W, 5000K, Carbon Bronze	XTOR4B=38W, 5000K, Carbon Bronze
XTOR1B-WT=12W, 5000K, Summit White	XTOR2B-W=18W, 4000K, Carbon Bronze	XTOR3B-W=26W, 4000K, Carbon Bronze	XTOR4B-W=38W, 4000K, Carbon Bronze
XTOR1B-PC1=12W, 5000K, 120V PC, Carbon Bronze	XTOR2B-WT=18W, 5000K, Summit White	XTOR3B-WT=26W, 5000K, Summit White	XTOR4B-WT=38W, 5000K, Summit White
XTOR1B-W=12W, 4000K, Carbon Bronze	XTOR2B-PC1=18W, 5000K, 120V PC, Carbon Bronze	XTOR3B-PC1=26W, 5000K, 120V PC, Carbon Bronze	XTOR4B-PC1=38W, 5000K, 120V PC, Carbon Bronze
XTOR1B-W-PC1=12W, 4000K, 120V PC, Carbon Bronze	XTOR2B-W-PC1=18W, 4000K, 120V PC, Carbon Bronze		XTOR4B-W-PC1=38W, 4000K, 120V PC, Carbon Bronze

BUILDINGS & SAFETY ENGINEERING DEPARTMENT

THIS PERMIT CONVEYS NO RIGHT TO OCCUPY ANY STREET, ALLEY OR SIDEWALK OR ANY PART THEREOF, EITHER TEMPORARILY OR PERMANENTLY. ENCROACHMENTS ON PUBLIC PROPERTY, NOT SPECIFICALLY PERMITTED UNDER THE BUILDING CODE, MUST BE APPROVED BY THE CITY COUNCIL. STREET OR ALLEY GRADES AS WELL AS DEPTH AND LOCATION OF PUBLIC SEWERS MAY BE OBTAINED FROM THE CITY ENGINEERING DEPARTMENT. THE ISSUANCE OF THIS PERMIT DOES NOT RELEASE THE APPLICANT FROM THE CONDITIONS OF ANY APPLICABLE SUBDIVISION RESTRICTIONS.

MINIMUM OF THREE CALL INSPECTIONS REQUIRED FOR ALL CONSTRUCTION WORK:

1. FOUNDATION OR FOOTINGS.
2. PRIOD TO COVERING STRUCTURAL MEMBERS (READY TO LATH).
3. FINAL INSPECTION BEFORE OCCUPANCY.

APPROVED PLANS MUST BE RETAINED ON JOB AND THIS CARD ALONG WITH THE GOLD COPY OF THE BUILDING PERMIT KEPT POSTED UNTIL FINAL INSPECTION HAS BEEN MADE. WHERE A CERTIFICATE OF OCCUPANCY IS REQUIRED, SUCH BUILDING SHALL NOT BE OCCUPIED UNTIL FINAL INSPECTION HAS BEEN MADE.

WHERE APPLICABLE SEPARATE PERMITS ARE REQUIRED FOR ELECTRICAL, PLUMBING AND MECHANICAL INSTALLATIONS.

CASE NO.

PERMIT NUMBER

2019 05986

POST THIS CARD

BUILDING INSPECTION APPROVALS	PLUMBING INSPECTION APPROVALS	ELECTRICAL INSPECTION APPROVALS
<p>① DRAIN TITLE AND FOUNDATION _____ DATE _____ INSPECTOR _____</p>	<p>① BUILDING SEWER (A) SANITARY _____ DATE _____ INSPECTOR _____ (B) STORM _____ DATE _____ INSPECTOR _____</p>	<p>① ROUGHING IN _____ DATE _____ INSPECTOR _____</p>
<p>② SUPERSTRUCTURE (PRIOR TO LATH AND PLASTER) _____ DATE _____ INSPECTOR _____</p>	<p>② CROCK TO IRON _____ DATE _____ INSPECTOR _____</p>	<p>② FINAL INSPECTOR _____ DATE _____ INSPECTOR _____</p>
<p>③ FINAL INSPECTION _____ DATE _____ INSPECTOR _____</p>	<p>③ UNDERGROUND STORM DRAINS _____ DATE _____ INSPECTOR _____</p>	<p>SAFETY ENGINEERING APPROVAL</p>
<p>WORK SHALL NOT PROCEED UNTIL EACH BUREAU HAS APPROVED THE VARIOUS STAGES OF CONSTRUCTION.</p>	<p>④ ROUGH PLUMBING _____ DATE _____ INSPECTOR _____</p>	<p>APPROVED _____ DATE _____ INSPECTOR _____</p>
	<p>⑤ WATER PIPING FINAL INSPECTION _____ DATE _____ INSPECTOR _____</p>	<p>INSPECTIONS INDICATED ON THIS CARD CAN BE ARRANGED FOR BY TELEPHONE OR WRITTEN NOFTICATION 224-3212</p>

WEATHER CARD

PERMIT WILL BECOME NULL AND VOID IF CONSTRUCTION WORK IS NOT STARTED WITHIN SIX MONTHS OF DATE THE PERMIT IS ISSUED.



City of Detroit
Buildings, Safety Engineering and Environmental Department
Building Division
Coleman A. Young Municipal Center
2 Woodward Avenue, 4th Floor, Suite 408, Detroit, Michigan 48226
(313) 224-3202

BUILDING PERMIT

SITE ADDRESS: 3960 Third PERMIT NO.: BLD2019-05986
 PARCEL NUMBER: 43403 SECTOR: APPLIED: 11/07/2019
 TYPE OF WORK: Alteration ISSUED: 11/12/2019
 ESTIMATED COST : \$496,838.00 EXPIRES: 05/10/2020
 USE: Repair Garage PMR No.:
 PERMIT DESCRIPTION: INTERIOR ALTERATIONS PER PLANS, PROJDOX BLD 8552

ZONING DISTRICT: SD2-Special Development 2-Mixed Use USE GRP: B-304.1 FL AREA:
 BLDG TYPE CODE: STORIES: 1 GROUND AREA:
 BETWEEN: Between and SIZE:
 LOT NO.: SUBDIVISION: 43403

<u>Owner</u>	<u>Applicant</u>	<u>Contractor</u>
	WILSON CONSTRUCTION COMPANY 2790 ISLAND VIEW ROAD TRVERSE CITY, MI 49686	

Fees			
Type	Status	Date	Amount
Building Permit Fee Balance (70%)	INVOICED	11/07/2019	\$7,035.00
	Total:		\$7,035.00

Please be advised per the 2015 Michigan Building Code: Each permit issued by the code official under the provisions of the code shall expire by limitation and become null and void if the work authorized by the permit has not begun within 180 days from the issued date of the permit or if not inspected, after the work has begun for a period of 180 days. Before the work may be restarted, the permit shall be reinstated if the code has not changed. If the code has changed and the work was not started, a new permit is required based on the current requirements.



HDC STAFF VISIT 10/29/19



HDC STAFF VISIT 10/29/19



HDC STAFF VISIT 10/29/19



HDC STAFF VISIT 10/29/19



HDC STAFF VISIT 10/29/19





Existing Clerestory looks to be covered with rolled roofing

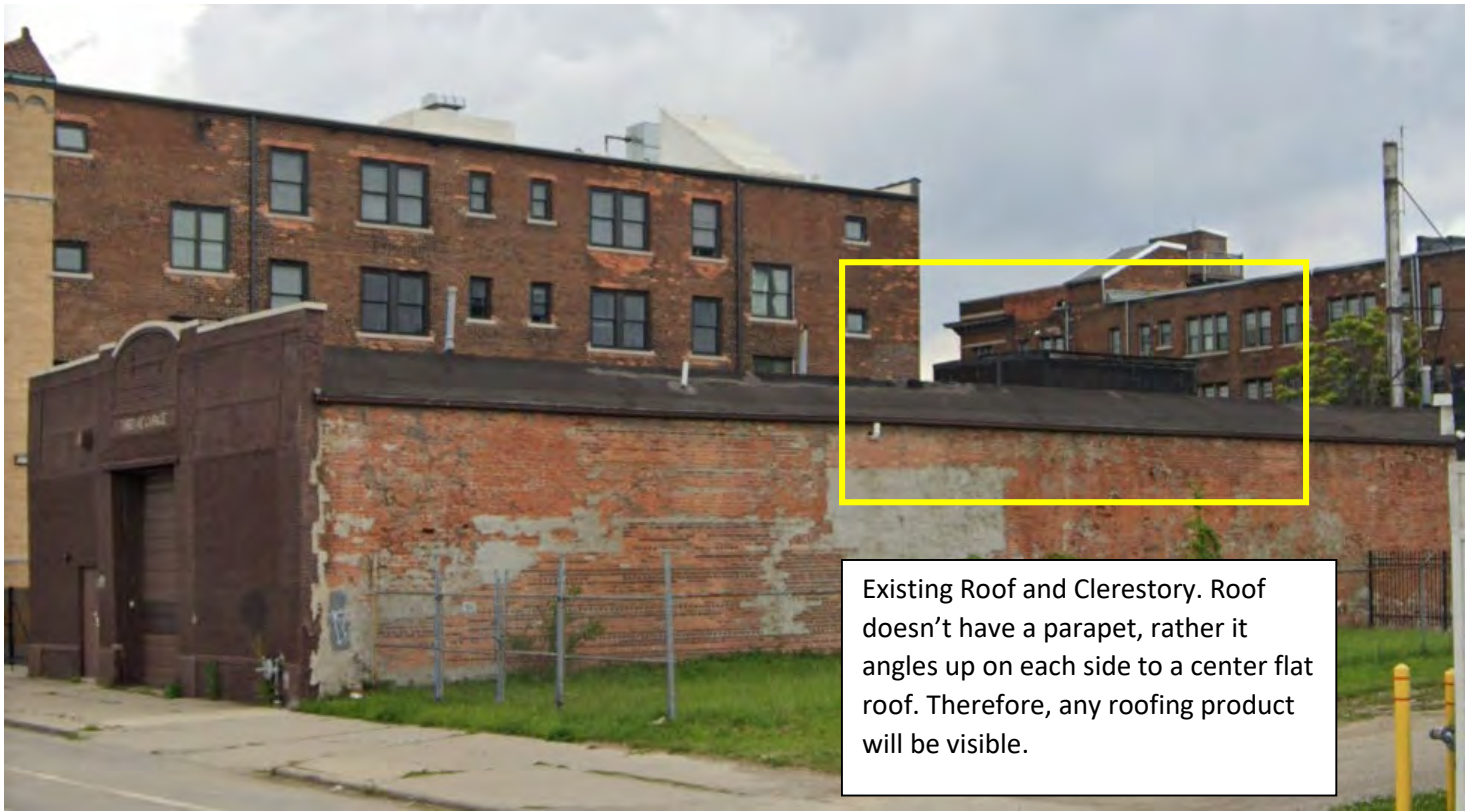

Existing Roof and Clerestory. Roof doesn't have a parapet, rather it angles up on each side to a center flat roof. Therefore, any roofing product will be visible.

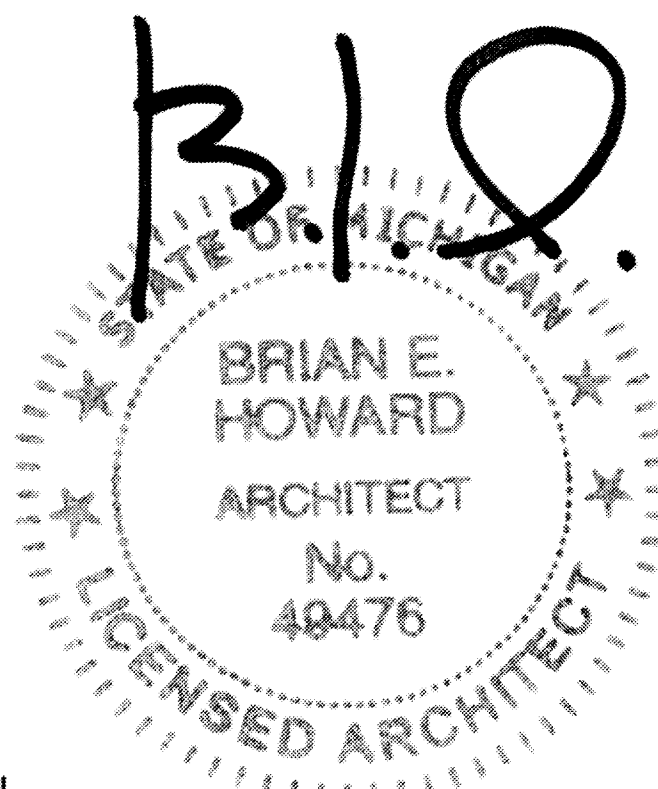

EXP. DATE
10/31/19

THIRD STREET BUILDING RENOVATION

3960 THIRD STREET
DETROIT, MICHIGAN

ELECTRICAL-FLOOR PLAN	E101	MECHANICAL-FLOOR PLAN	M101
ELECTRICAL-SCHEDULE/DETAILS	E201	MECHANICAL-SCHEDULE/DETAILS	M201
		PLUMBING-FLOOR PLAN	P101

ARCHITECTURAL SHEET INDEX:

FLOOR PLAN	A101
EAST/WEST ELEVATIONS	A200
NORTH/SOUTH ELEVATIONS	A201
ALTA SURVEY	1

HF:architecture®
HARMONY | FORM
512 NORTH MAIN STREET | SUITE 100
ROYAL OAK | MICHIGAN 48067
248 | 388 | 8553 | www.hfarchitecture.com

ISSUE DATE
10.08.18

ISSUE FOR
BIDDING | PERMIT | CONSTRUCTION

PROJECT
THIRD STREET BUILDING RENOVATION
3960 THIRD STREET
DETROIT, MICHIGAN

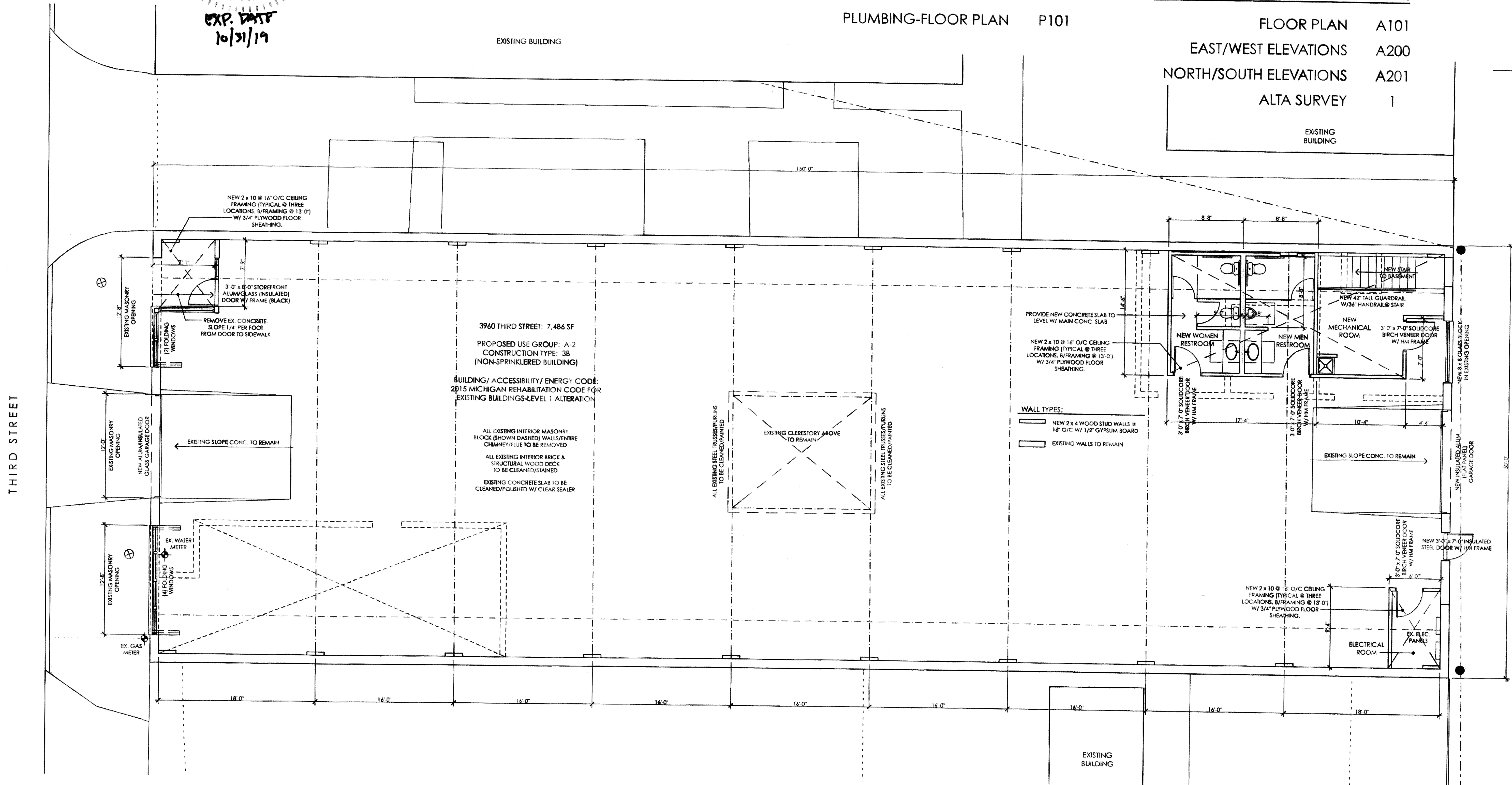

FLOOR PLAN
SCALE: 3/16" = 1'-0"

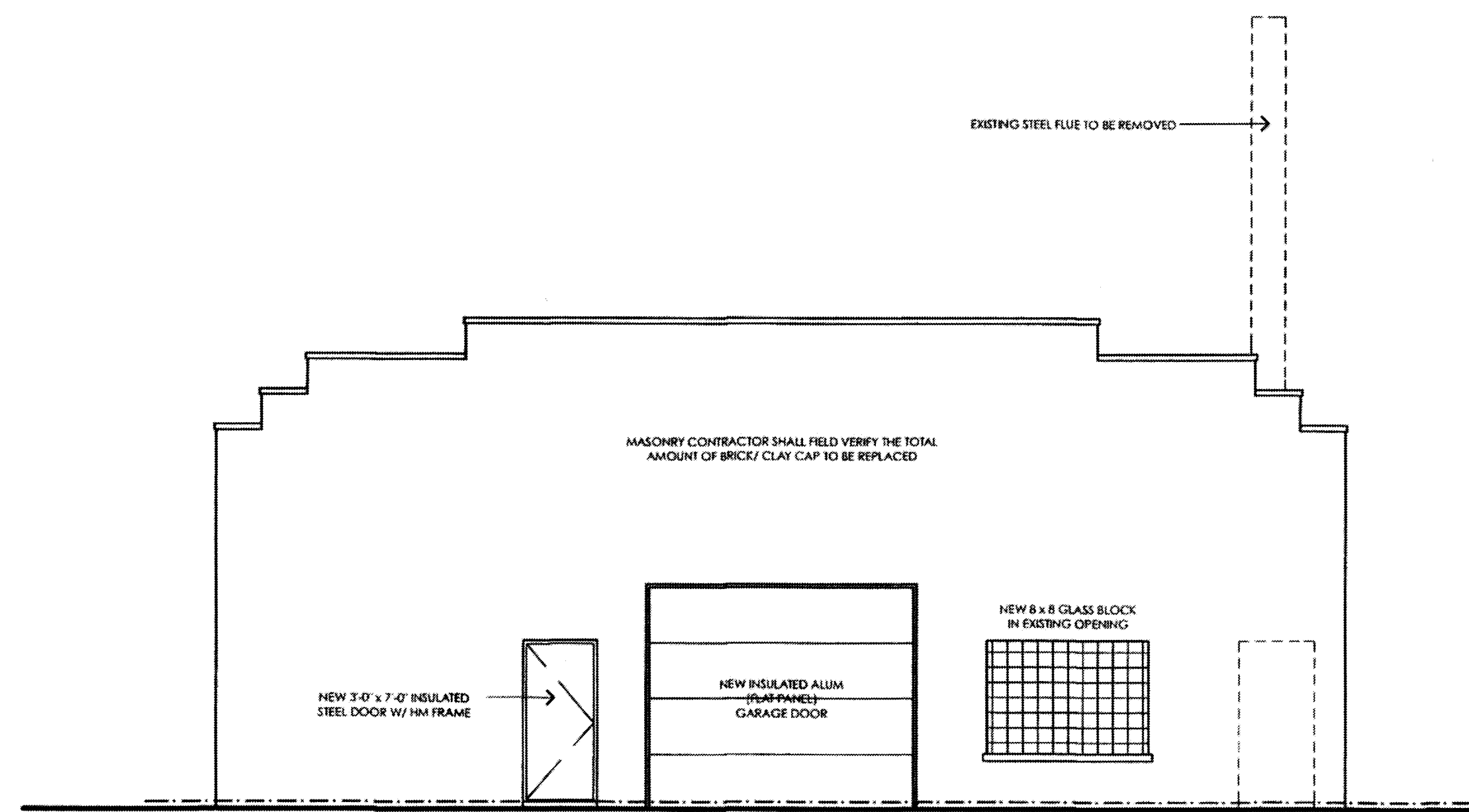
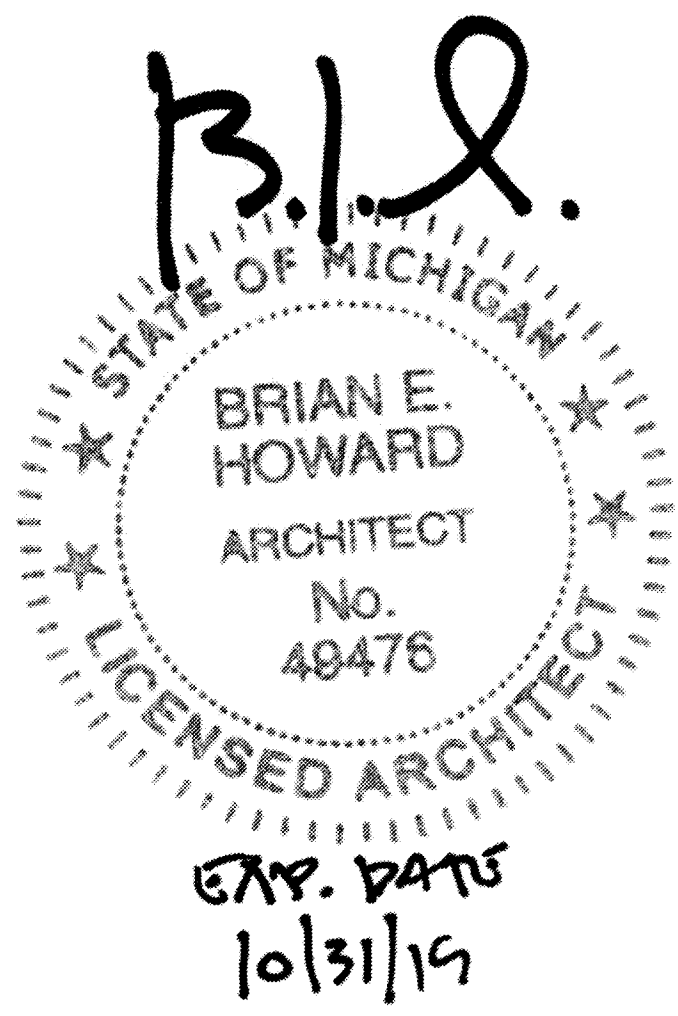

EAST ELEVATION
 SCALE: 1/4" = 1'-0"



WEST ELEVATION
 SCALE: 1/4" = 1'-0"

ISSUE DATE
10.08.18

ISSUE FOR
BIDDING | PERMIT | CONSTRUCTION

PROJECT
THIRD STREET BUILDING RENOVATION
 3960 THIRD STREET
 DETROIT, MICHIGAN

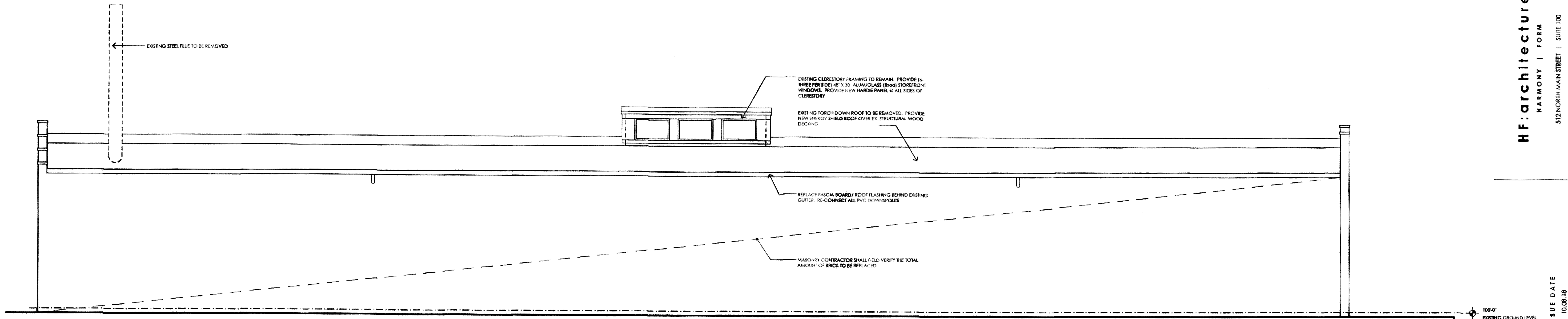

THIRD STREET

ISSUE DATE
10.08.19

B.E.H.

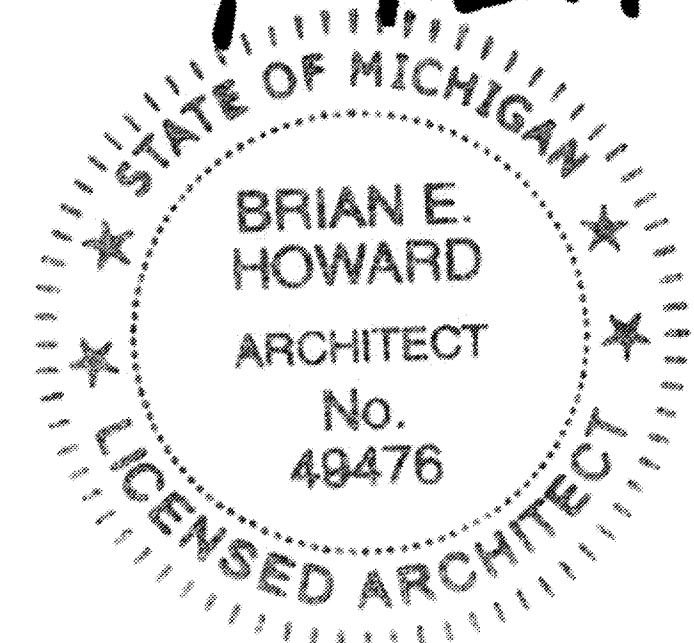

EXP. DATE
10/31/19

NORTH ELEVATION
SCALE: 1/4" = 1'-0"

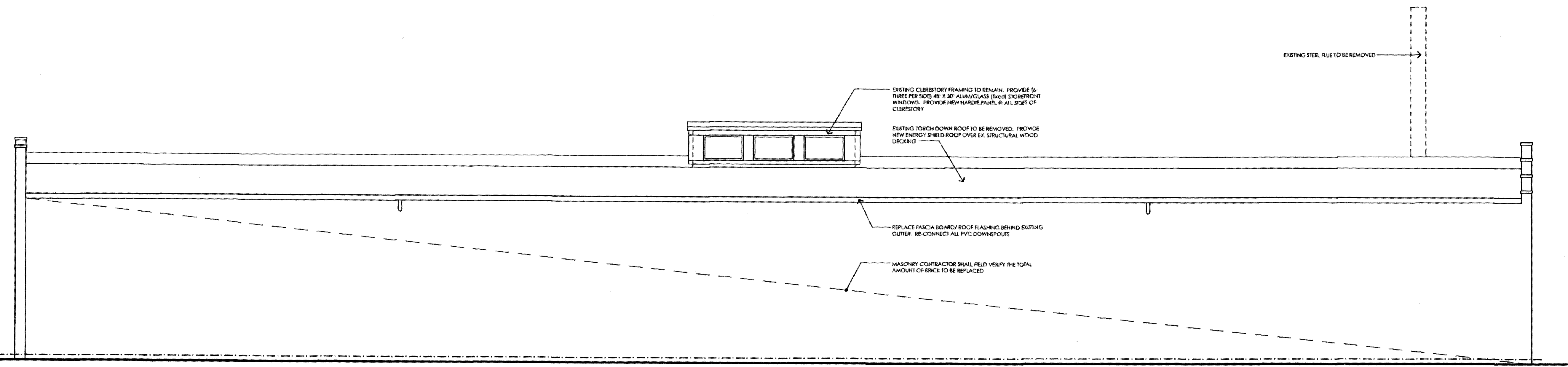

THIRD STREET

ISSUE FOR
BIDDING | PERMIT | CONSTRUCTION

PROJECT
THIRD STREET BUILDING RENOVATION
3960 THIRD STREET
DETROIT, MICHIGAN

SOUTH ELEVATION
SCALE: 1/4" = 1'-0"

THIS DOCUMENT IS PROTECTED BY COPYRIGHT. COPY ONLY WHEN APPROVED BY THE ENGINEER BY WRITTEN INSTRUMENT.

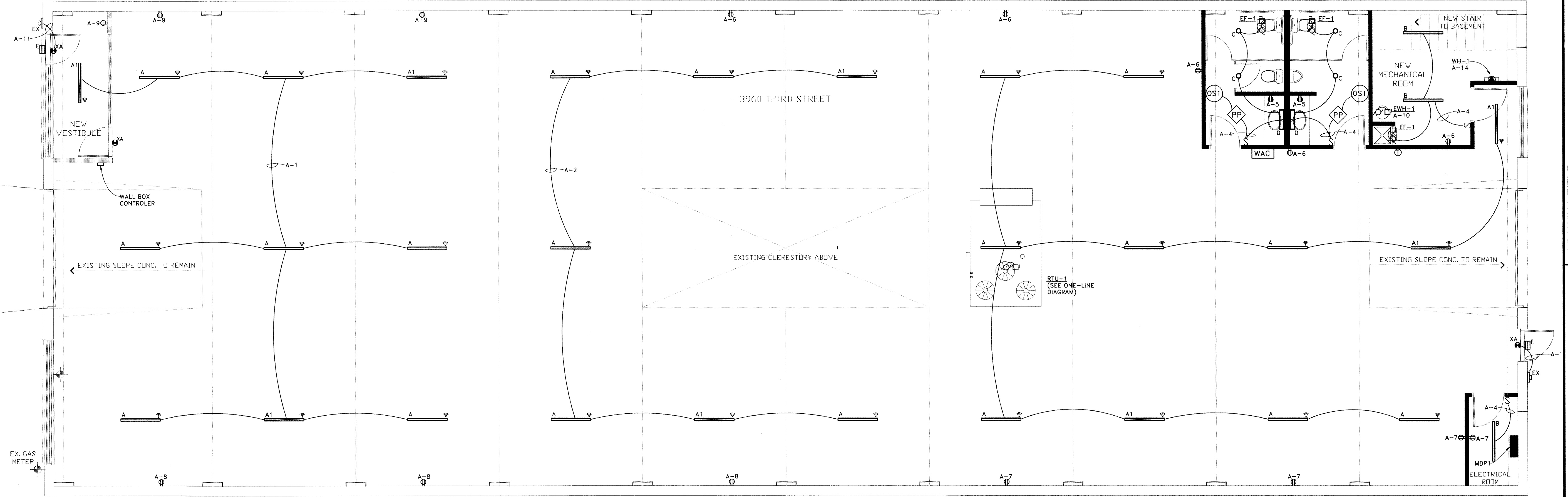

FLOOR PLAN - ELECTRICAL

SCALE: 3/16" = 1'-0"

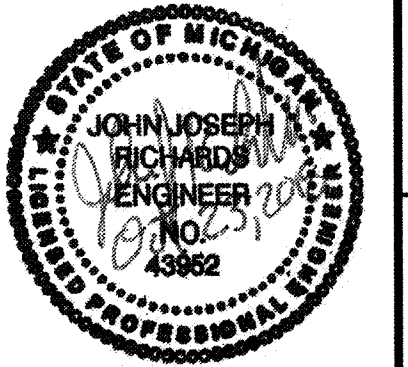
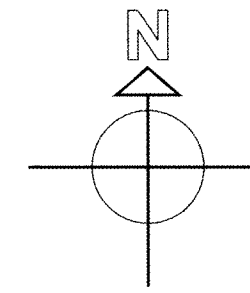

ELECTRICAL NOTES

- PRIOR TO SUBMITTING A PROPOSAL, BIDDER SHALL HAVE VISITED THE CONSTRUCTION SITE. HE SHALL BE FAMILIAR WITH THE EXISTING CONDITIONS UNDER WHICH HE WILL HAVE TO OPERATE AND WHICH WILL IN ANY WAY AFFECT THE WORK UNDER THIS CONTRACT. NO SUBSEQUENT ALLOWANCE WILL BE MADE IN THIS CONNECTION ON BEHALF OF THE CONTRACTOR FOR ANY ERROR OR NEGLIGENCE ON HIS PART.
- ELECTRICAL WORK SHALL COMPLY WITH THE LATEST ENFORCEABLE EDITION OF THE N.E.C., LOCAL AND STATE CODES, ORDINANCES, REGULATIONS, INCLUDING THE OCCUPATIONAL SAFETY AND HEALTH ACT (OSHA), AND ADA GUIDELINES WITH THE LOCAL CODE AUTHORITIES HAVING JURISDICTION.
- ELECTRICAL CONTRACTOR SHALL OBTAIN ALL PERMITS, PAY ALL FEES, INCLUDING COSTS ASSESSED BY THE ELECTRIC TO THE UTILITY COMPANIES, AND ARRANGE FOR ALL INSPECTIONS FOR HIS WORK. AT THE COMPLETION OF ELECTRICAL WORK, THE ELECTRICAL CONTRACTOR SHALL FURNISH THE OWNER WITH ALL CERTIFICATES OF FINAL INSPECTION AND APPROVALS.
- ELECTRICAL MATERIALS SHALL BE NEW, AND BEAR THE "UL" LABEL.
- BRANCH CIRCUIT WIRE FOR LIGHTING, RECEPTACLE AND SMALL POWER SHALL BE COPPER, RATED 75 DEGREES C, MINIMUM SIZE #12 AWG, AND BE TYPE "THHN", AND BE INSTALLED IN EMT, UNLESS OTHERWISE NOTED OR REQUIRED BY CODE. FEEDERS AND SECONDARY SERVICE CONDUCTORS SHALL BE STRANDED COPPER WITH 600 VOLT INSULATION, RATED 90 DEGREES C, TYPE "THHN", AND BE INSTALLED IN EMT OR PVC CONDUIT, MINIMUM SIZE 1/2". UNLESS OTHERWISE NOTED OR REQUIRED BY CODE, ALL WIRE AND CABLE SHALL BE NEW AND SHALL BE DELIVERED TO PROJECT IN UNBROKEN AND UNDAMAGED CARTONS AND REELS.
- FUSES SHALL BE "UL" LISTED, DUAL AS MANUFACTURED BY BUSMAN CO., OR APPROVED EQUAL (200,000 ERIC).
- PLATES FOR SWITCHES AND RECEPTACLES SHALL BE PLASTIC, COLOR TO BE WHITE.
- FLUORESCENT FIXTURE BALLAST VOLTAGE RATING SHALL BE AS NOTED, NON, HIGH POWER FACTOR, ENERGY SAVING, CLASS P, "A", SOUND RATED, HIGH DISCHARGE (HD) BALLAST SHALL BE NON, HIGH POWER FACTOR, CONSTANT WATTAGE AUTO TRANSFORMER TYPE, WITH STARTING CURRENT NOT EXCEEDING THE OPERATING CURRENT.
- PANEL BOARDS SHALL BE RATED 120/240V, 1 PHASE, 4W, AS NOTED WITH PLUG TYPE BRANCH CIRCUIT BREAKERS RATED A MINIMUM 10,000 A.I.C. PANEL BOARDS SHALL BE SIMILAR TO SQUARE D, TYPE QO AND I-LINE, OR EQUAL BY WESTINGHOUSE/CHALLENGER, E.T.A., OR GENERAL ELECTRIC.
- ELECTRICAL CONTRACTOR SHALL VERIFY EXACT ELECTRIC UTILITY COMPANIES SERVICE POINTS AND PRIMARY SERVICE CONDUIT, ROUTING, AND SIZE WITH UTILITY COMPANY SERVICE PLANNERS PRIOR TO BEGINNING WORK.
- ELECTRICAL CONTRACTOR SHALL GUARANTEE ALL WORK INSTALLED UNDER HIS CONTRACT TO BE FREE FROM DEFECTIVE WORKMANSHIP AND MATERIALS FOR A PERIOD OF ONE YEAR AFTER THE ACCEPTANCE OF THE BUILDING BY THE OWNER. SHOULD DEFECTS OCCUR WITHIN THIS PERIOD, REPAIR AND/OR REPLACE DEFECTIVE ITEMS AT NO EXPENSE TO CONTRACTOR.
- ELECTRICAL CONTRACTOR SHALL COORDINATE LOCATIONS OF HIS EQUIPMENT AND WORK WITH OTHER BUILDING TRADES TO AVOID ANY INTERFERENCE'S BETWEEN HIS WORK AND THE WORK OF OTHER BUILDING TRADES. IF ANY DISCREPANCIES OCCUR, CONSULT WITH THE ARCHITECT AND/OR OWNER BEFORE CONTINUING.
- LAMPS - ALL LAMPS SHALL BE CLASSIFIED "ENERGY SAVING", AND BE PROVIDED BY E.C.
- THE CONTRACTOR SHALL BE HELD FULLY RESPONSIBLE FOR THE PROPER RESTORATION OF ALL EXISTING SURFACES REQUIRING PATCHING, PLASTERING, PAINTING AND/OR OTHER REPAIR DUE TO THE INSTALLATION OF ELECTRICAL WORK UNDER THE TERMS OF THIS SPECIFICATION. CLOSE ALL OPENINGS, REPAIR ALL SURFACES.
- THE ELECTRICAL CONTRACTOR SHALL PERIODICALLY REMOVE FROM THE SITE ALL DEBRIS AND RUBBISH ACCUMULATING AS A RESULT OF THE ELECTRICAL INSTALLATION. UPON COMPLETION OF THE PROJECT, HE SHALL DISPOSE OF ALL DEBRIS AND RUBBISH AND SHALL LEAVE ALL AREAS CLEAN. THE INTERIORS OF ALL CABINETS, PULL BOXES, AND EQUIPMENT ENCLOSURES SHALL BE FREE OF ANY DEBRIS.
- UNDERGROUND CONDUIT TO BE SCHEDULE 40 PVC.
- ELECTRICAL JOINTS WILL BE PERMITTED ONLY IN JUNCTION AND OUTLET BOXES. ALL JOINTS SHALL BE FIRMLY BONDED TOGETHER AND TAPED OR SHALL BE MADE WITH MECHANICAL CONNECTORS.

ELECTRICAL SYMBOL LEGEND

SYMBOL	DESCRIPTION	NOTES
S	SINGLE POLE SWITCH	MOUNT @ 44" A.F.F. TO BOTTOM OF BOX, UNLESS OTHERWISE NOTED
○x	LED CAN FIXTURE	SEE LIGHTING FIXTURE SCHEDULE FOR TYPES
—x	1'x2' VANITY FIXTURE, TYPE X	SEE LIGHTING FIXTURE SCHEDULE FOR TYPES
—x	1'x4' SUSPENDED FIXTURE, TYPE X	SEE LIGHTING FIXTURE SCHEDULE FOR TYPES
—x	1'x4' SUSPENDED FIXTURE, TYPE X, WITH WIRELESS OCCUPANCY SENSOR.	SEE LIGHTING FIXTURE SCHEDULE FOR TYPES
⊗x	EXIT SIGN, TYPE X	SEE LIGHTING FIXTURE SCHEDULE FOR TYPES
⊕	DUPLEX OUTLET - 20 AMP	MOUNT @ 12" A.F.F. TO BOTTOM OF BOX, UNLESS OTHERWISE NOTED
⊕	DUPLEX OUTLET - GROUND FAULT	MOUNT @ 12" A.F.F. TO BOTTOM OF BOX, UNLESS OTHERWISE NOTED
⊕	DUPLEX OUTLET - WEATHER PROOF COVER	MOUNT @ 12" A.F.F. TO BOTTOM OF BOX, UNLESS OTHERWISE NOTED
⊕	SPECIAL PURPOSE OUTLET, AS NOTED	REFER TO SHOP DRAWINGS FOR CONNECTION REQUIREMENTS
⊕	MOTOR, AS SPECIFIED	REFERENCE SPECIFICATIONS FOR REQUIREMENTS
⊕	FUSED DISCONNECT	REFER TO GENERAL ELECTRICAL NOTES AND ONE-LINE DIAGRAM.
⊕	STARTER/DISCONNECT	REFERENCE SPECIFICATIONS FOR REQUIREMENTS (VFD IS BEING SUPPLIED WITH UNIT FOR ROOTOPTS OR BY CONT. CONTRACTOR) PROVIDE ALL LINE VOLTAGE WIRING AND CONDUIT FOR VFD INSTALL.
⊕	FUSED DISCONNECT FOR VFD CONNECTION	
⊕	LIGHTING BRANCH CIRCUIT PANELS	REFER TO GENERAL ELECTRICAL NOTES AND ONE-LINE DIAGRAM.
⊕	MECHANICAL THERMOSTAT	PROVIDE CONDUIT AND BACKBOX

OCCUPANCY LEGEND

SYMBOL	BRAND	MODEL #	DESCRIPTION
OSI	GREENGATE	OAC-P-1500-R	CEILING MOUNTED PASSIVE INFRARED OCCUPANCY SENSOR (1500 SQ. FT.)
PP	GREENGATE	SP20-MV	POWER PACK FOR 120/277VAC SYSTEM

ELECTRIC WALL HEATER SCHEDULE

MARK	MANU.	MODEL No.	BTU/HR.	WATTS	ELECTRICAL	REMARKS
WH-1	MARKEL	E3323TD-RP	5,120	1500	120v/1#, 1500W	BUILT IN THERMISTAT& CIRCUIT BREAKER

NOTES:
1. UNITS BASED ON MARKEL. (O-MARK & ELECTROMODE MAY BE BID AS EQUAL).

LIGHTING FIXTURE SCHEDULE

TYPE	BRAND	MODEL #	MOUNTING TYPE	LAMP	TOTAL FIXTURE POWER	VOLTAGE	NOTES:
A	METALUX	4WSL-LD2-60-SPS-UNV-L835-CD1-SWPD1-U	SUSPENDED	598BLM/3500K/LED	56.2W	UNV	-
A1	METALUX	4WSL-LD2-60-SPS-UNV-EL14W-L835-CD1-SWPD1-U	SUSPENDED	598BLM/3500K/LED	56.2W	UNV	W/ INTEGRAL BATTERY PACK
A2	METALUX	4WSL-LD2-60-SPS-UNV-L835-CD1-SWPD1-U	SUSPENDED	598BLM/3500K/LED	56.2W	UNV	-
B	METALUX	SNLED-LD5-46SL-LN-UNV-L835-CD1-U	SURFACE	4581LM/3500K/LED	35W	UNV	-
C	HALO COMMERCIAL	PD615ED010B-PD68835-61VMH	RECESSED	1500LM/3500K/LED	17.1W	UNV	-
D	PRUDENTIAL LTG.	FLAIR-LED35-SO-2-SAL-TMW-UNV-SUR-DM10	SURFACE	2500LM/3500K/LED	20W	UNV	-
E	LUMARK	XTOR1B-W-XX-PC1	SURFACE	990LM/4000K/LED	12W	UNV	W/ PHOTO CELL
XA	SURE-LITES	APCH7R	UNIVERSAL	(1) LED	2.34W	120V	W/ OUT LED HEADS
EM	SURE-LITES	APEL	UNIVERSAL	LED	.33W	3.6v	-

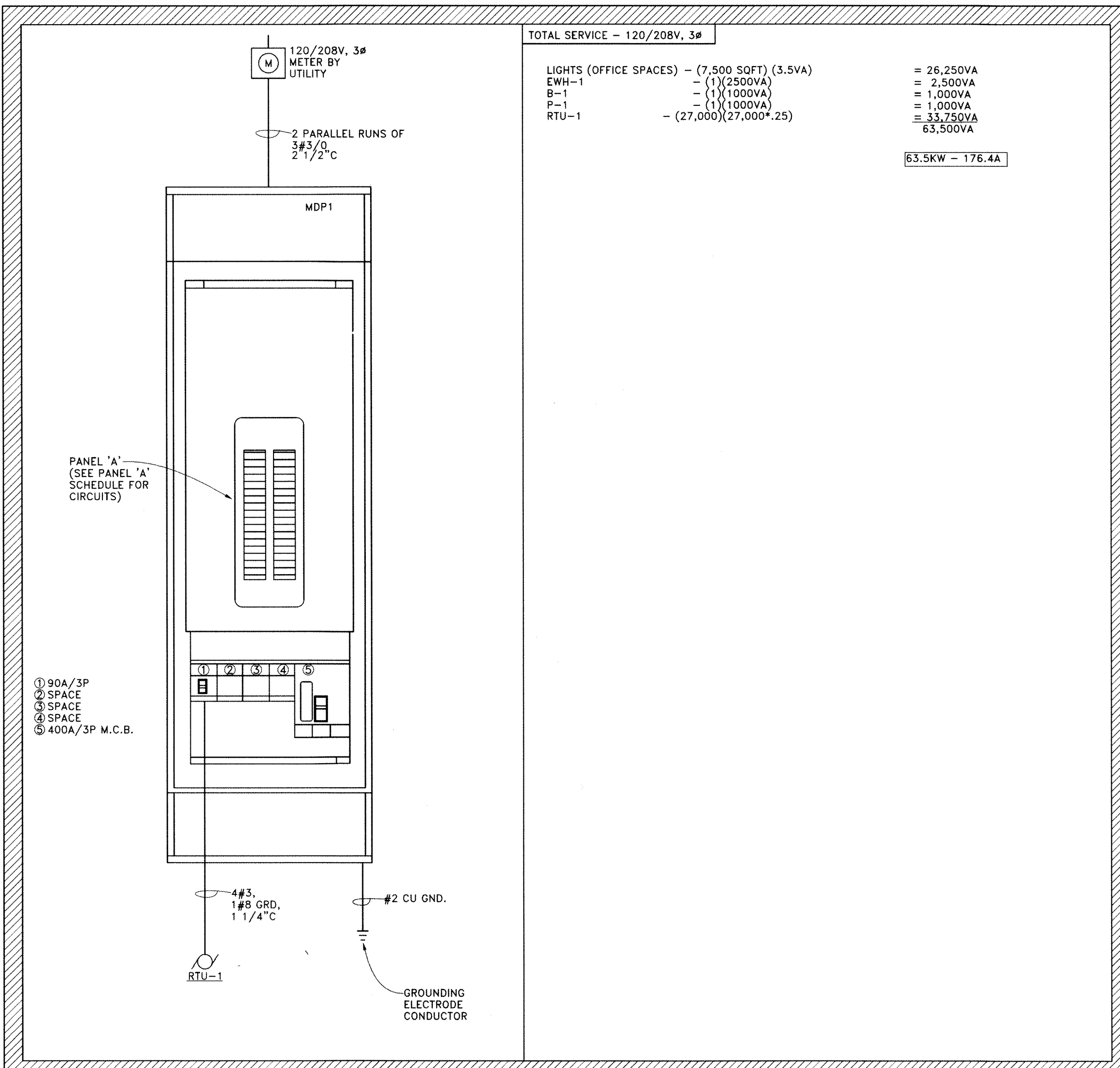

ONE-LINE DIAGRAM
NOT TO SCALE

PANEL A

PART OF I-LINE COMBO PANEL

CR NO.	AMPS	POLES	DESCRIPTION	LOAD	LOAD	DESCRIPTION	AMPS	CR NO.
1	20/1		LIGHTS (OFFICE)	1388	1040	LIGHTS (OFFICE)	20/1	2
3	20/1		LIGHTS (OFFICE)	1537	250	LIGHTS (BATH/MECH/ELECT)	20/1	4
5	20/1		RECEPTACLES (BATHROOMS)	360	900	RECEPTACLES (OFFICE)	20/1	6
7	20/1		RECEPTACLES (OFFICE/ELECT.)	720	540	RECEPTACLES (OFFICE)	20/1	8
9	20/1		RECEPTACLES (OFFICE)	540	2500	EWH-1 (MECHANICAL)	30/1	10
11	20/1		LIGHTS (EXTERIOR)	100	1000	B-1 (MEZZ.)	20/1	12
13	15/1		EF-1 (MEZZ.)	528	1500	EH-1 (MECHANICAL)	20/1	14
15	20/1		SPARE	---	---	SPARE	20/1	16
17	---		SPACE	---	---	SPACE	---	18
19	---		SPACE	---	---	SPACE	---	20
21	---		SPACE	---	---	SPACE	---	22
23	---		SPACE	---	---	SPACE	---	24
25	---		SPACE	---	---	SPACE	---	26
27	---		SPACE	---	---	SPACE	---	28
29	---		SPACE	---	---	SPACE	---	30
31	---		SPACE	---	---	SPACE	---	32
33	---		SPACE	---	---	SPACE	---	34
35	---		SPACE	---	---	SPACE	---	36
37	---		SPACE	---	---	SPACE	---	38
39	---		SPACE	---	---	SPACE	---	40
41	---		SPACE	---	---	SPACE	---	42

WIRE SIZE REQUIREMENTS

NOTE:
BASED ON A MAXIMUM OF 6-VOLT DROP (5%) ON 120V CIRCUITS. WIRES FOR RUNS OVER 100'-0" SHALL BE DETERMINED ON THIS A MAXIMUM OF A 5% DROP ALLOWED.

BRANCH CIRCUIT AMPS	LENGTH OF RUN - FROM PANEL TO FIRST CONNECTION - FEET									
	50'	60'	70'	80'	90'	100'	110'	120'	130'	
15	#12	#12	#12	#12	#12	#12	#10	#10	#10	
20	#12	#12	#12	#10	#10	#10	#10	#10	#8	
30	#10	#10	#10	#10	#8	#8	#8	#8	#6	

EATON WAVELINK BILL OF MATERIALS

- - EATON W4S-RL-X WALL BOX CONTROLLER (VERIFY COLOR WITH OWNER)
- [WAC] - EATON WAC-POE WIRELESS AREA CONTROLLER.
- ⚡ - LIGHTING FIXTURE WITH INCLUDED WAVELINK SENSOR
- SUPPLIER TO PROVIDE INITIAL PROGRAMING AND TRAINING FOR WAVELINK SYSTEM. (CONTACT CRITES TIDEY (231) 941-8888)

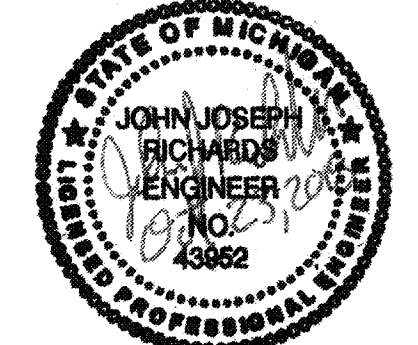

THIS DOCUMENT IS PROTECTED BY COPYRIGHT. COPY ONLY WHEN APPROVED BY THE ENGINEER BY WRITTEN INSTRUMENT.

12719 S. WEST BAYSHORE DR.
SUITE 100
LIVESTONE, MI 48884
CITY OF LIVESTONE OFFICE
(231) 421-6794 Fax
E-Mail: apollo_mf_eng@yahoo.com

DRAWING TITLE
SCHEDULES / NOTES / DETAILS
- ELECTRICAL

PROJECT TITLE
RENOVATION PROJECT FOR:
3960 THIRD STREET
DETROIT, MI

PROJECT NO.
1807-05

DATE
JULY 26, 2018
OCT. 23, 2018

SHEET
E102

GENERAL NOTES

- ALL CONSTRUCTION AND MATERIALS SHALL CONFORM TO ALL APPLICABLE FEDERAL, STATE, AND LOCAL CODES AND REGULATIONS.
- PROJECT TO COMPLY WITH CURRENT AMERICANS WITH DISABILITIES ACT (ADA) REQUIREMENTS.
- EACH CONTRACTOR SHALL BE THOROUGHLY KNOWLEDGEABLE OF REGULATIONS GOVERNING HIS PRODUCT AND SERVICE AND SHALL ASSUME RESPONSIBILITY OF INSTALLATION IN ACCORDANCE WITH THOSE REGULATIONS.
- CONTRACTORS TO VERIFY ALL DIMENSIONS RELATIVE TO THEIR SPECIFIC WORK AND SHALL BE THOROUGHLY FAMILIAR WITH EXISTING CONDITIONS PRIOR TO INITIATING THEIR WORK. DISCREPANCIES SHALL BE REPORTED TO THE GENERAL CONTRACTOR OR TO HIS ON-SITE REPRESENTATIVE.
- FAILURE TO DETECT INFERIOR WORK, OR WORK NOT IN ACCORDANCE WITH THESE CONSTRUCTION DOCUMENTS, SHALL NOT BE CONSTRUED AS ACCEPTABLE OF SUCH WORK.
- ANY PENETRATIONS THROUGH FIRE-RATED ASSEMBLIES FOR MECHANICAL OR PLUMBING SYSTEMS, ETC. SHALL BE FIRE-STOPPED AND DRAFT-STOPPED WITH NON-COMBUSTIBLE MATERIALS PER CODE REQUIREMENTS TO MAINTAIN STRUCTURAL AND FIRE RESISTIVE INTEGRITY.
- DRAWINGS ARE DIAGRAMMATIC ONLY, FIELD VERIFY EXISTING CONDITIONS.
- PRIOR TO SUBMITTING A PROPOSAL, BIDDER SHALL HAVE VISITED THE CONSTRUCTION SITE. HE SHALL BE FAMILIAR WITH THE EXISTING CONDITIONS UNDER WHICH HE WILL HAVE TO OPERATE AND WHICH WILL IN ANY WAY AFFECT THE WORK UNDER THIS CONTRACT. NO SUBSEQUENT ALLOWANCE WILL BE MADE IN THIS CONNECTION ON BEHALF OF THE CONTRACTOR FOR ANY ERROR OF NEGLIGENCE ON HIS PART.
- MECHANICAL CONTRACTOR SHALL OBTAIN ALL PERMITS PAY ALL FEES, INCLUDING COSTS ASSESSED BY THE MECHANICAL UTILITIES COMPANIES, AND ARRANGE FOR ALL INSPECTIONS FOR HIS WORK. AT THE COMPLETION OF MECHANICAL WORK, THE MECHANICAL CONTRACTOR SHALL FURNISH THE OWNER WITH ALL CERTIFICATES OF FINAL INSPECTION AND APPROVALS.
- MECHANICAL CONTRACTOR SHALL GUARANTEE ALL WORK INSTALLED UNDER HIS CONTRACT TO BE FREE FROM DEFECTIVE WORKMANSHIP AND MATERIALS FOR A PERIOD OF ONE YEAR AFTER THE ACCEPTANCE OF THE BUILDING BY THE OWNER. SHOULD DEFECTS OCCUR WITHIN THIS PERIOD, REPAIR AND/OR REPLACE DEFECTIVE ITEMS AT NO EXPENSE TO THE OWNER.
- MECHANICAL CONTRACTOR SHALL COORDINATE LOCATIONS OF HIS EQUIPMENT AND WORK WITH OTHER BUILDING TRADES TO AVOID ANY INTERFERENCES BETWEEN HIS WORK AND THE WORK OF OTHER BUILDING TRADES. IF ANY DISCREPANCIES OCCUR, CONSULT WITH THE GENERAL CONTRACTOR BEFORE CONTINUING.
- THE CONTRACTOR SHALL BE HELD FULLY RESPONSIBLE FOR THE PROPER RESTORATION OF ALL EXISTING SURFACES REQUIRING PATCHING, PLASTERING, PAINTING AND/OR OTHER REPAIR DUE TO THE INSTALLATION OF MECHANICAL WORK UNDER THE TERMS OF THIS SPECIFICATION. CLOSE ALL OPENINGS, REPAIR ALL SURFACES ETC. AS REQUIRED.
- THE CONTRACTOR SHALL EMPLOY QUALIFIED AND EXPERIENCED WORKMEN FOR THIS WORK.
- THE MECHANICAL CONTRACTOR SHALL PERIODICALLY REMOVE FROM THE SITE ALL DEBRIS AND RUBBISH ACCUMULATING AS A RESULT OF THE MECHANICAL INSTALLATION. UPON COMPLETION OF THE PROJECT, HE SHALL LEAVE ALL AREAS CLEAN.

MECHANICAL CONSTRUCTION NOTES

- GENERAL**
- THE CONTRACTOR SHALL CAREFULLY COORDINATE LOCATIONS OF DUCTS, REGISTERS, DIFFUSERS, AND GRILLES WITH STRUCTURAL FRAMING, ARCH TRADES, ELECTRICAL TRADES AND PLUMBING TRADES.
 - CONTRACTOR SHALL FURNISH COMPLETE AIR BALANCING REPORT TO THE GENERAL CONTRACTOR.
 - CUTTING AND/OR PATCHING THAT MAY BE REQUIRED FOR THE INSTALLATION OF THE MECHANICAL SYSTEM(S) SHALL BE DONE AND/OR REPAIRED BY THE MECHANICAL CONTRACTOR. NO CUTTING OF THE BUILDING STRUCTURAL SYSTEM SHALL BE DONE WITHOUT THE WRITTEN CONSENT OF THE ARCHITECT.
- SPECIFICATIONS**
- MECHANICAL DESIGN PER LATEST MICHIGAN MECHANICAL CODE.
 - VENTILATION REQUIREMENTS ARE MET BY MECHANICAL VENTILATION.
- DUCTWORK**
- SUSPEND ALL DUCTS SECURELY FROM ADJACENT BUILDING MEMBERS. DO NOT SUPPORT DUCTS FROM UNIT DUCT CONNECTORS. DUCT CONNECTIONS SHALL BE MADE IN ACCORDANCE WITH THE MANUFACTURER'S RECOMMENDATIONS AND SHALL INCLUDE FLEXIBLE DUCT CONNECTORS.
 - INCLUDE FIRE DAMPERS AT ALL WALL, CEILING OR FLOOR PENETRATIONS AS REQUIRED BY CODE. (SEE ARCH. DRAWINGS FOR FIRE RATED ASSEMBLIES.)
 - DUCTING FIRE DAMPERS: IF REQUIRED (PROVIDED BY M.C.)
 - DAMPERS BASED ON "RUSKIN", MODEL #D-IBD2, SIZED PER DUCT, W/FUSIBLE LINK (165°F).
 - INSTALLATION MUST COMPLY WITH THE REQUIREMENTS OF NFPA-90A, 92A AND THE STATE FIRE MARSHALL.
 - UNDER SLAB DUCT WORK TO BE EQUAL TO UNITED MCGILL UNI-COAT, PCD K27. DUCTING TO BE SEALED WATER TIGHT AS INSTRUCTED BY MANUF.
 - RETURN AIR DUCTWORK SHALL BE CONSTRUCTED AS PER SMACNA STANDARDS GAUGE GALVANIZED STEEL. NO INSULATION REQD. EXCEPT FOR ATTIC DUCTWORK. ALL RA & EA DUCT IN ATTIC TO HAVE MIN 1 1/2" INSULATION. ALSO, DUCTING TO BE LOCATED BELOW ATTIC INSULATION.
 - SUPPLY AIR DUCTWORK SHALL BE CONSTRUCTED AS PER SMACNA STANDARDS GAUGE GALVANIZED STEEL, WITH MINIMUM 1-1/2" INSULATION EQUAL TO OWENS CORNING ALL SERVICE DUCT WRAP TYPE 150 WITH FRK VAPOR BARRIER FACING. INSULATED FLEXIBLE DUCT MAY BE USED FOR ALL SHORT AIR DUCT RUNS.
 - ALL DUCTING IN ATTIC SHALL BE INSULATED WITH A MIN OF 3" CLOSED CELL SPRAY FOAM INSULATION WITH PROPER FIRE RETARDANT COATING.
 - INCLUDE MANUAL BALANCING DAMPERS AS REQUIRED FOR A COMPLETE AIR BALANCED SYSTEM.
- HEATING AND COOLING EQUIPMENT**
- ALL EQUIPMENT SHALL BE INSTALLED TO MANUFACTURER'S INSTALLATION INSTRUCTIONS.
 - ALL EQUIPMENT SHALL BE INSTALLED ACCORDING TO APPLICABLE STATE AND LOCAL CODES.
 - EQUIPMENT INSTALLATION SHALL BE COMPLETE AND INCLUDE COMPLETE GAS TRAIN WITH SHUT OFF COCKS, SEDIMENT TRAP, AND GAS PRESSURE REGULATOR.
 - ALLOW FOR BOILER VENTING TO EXPAND AND CONTRACT. INSTALL TO ELIMINATE NOISE.
 - AHU SHALL HAVE MOTORIZED DAMPERS TO INTERFACE WITH O.A. DAMPER TO ESTABLISH RELIEF MODE.

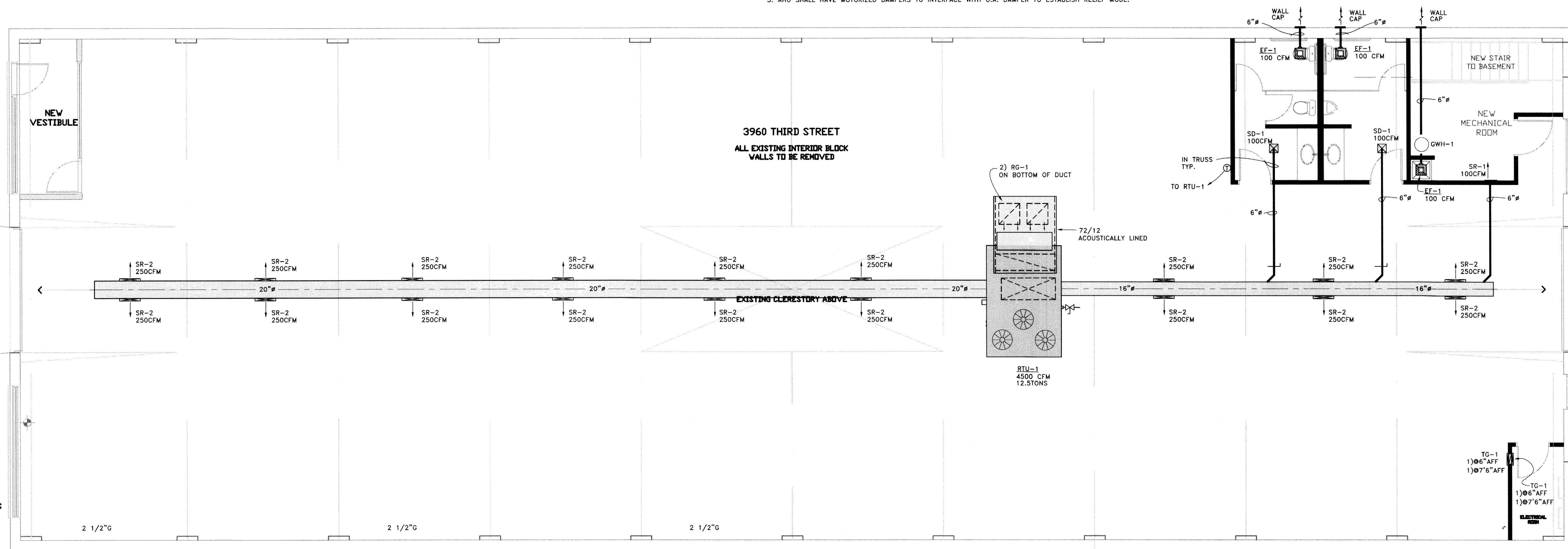
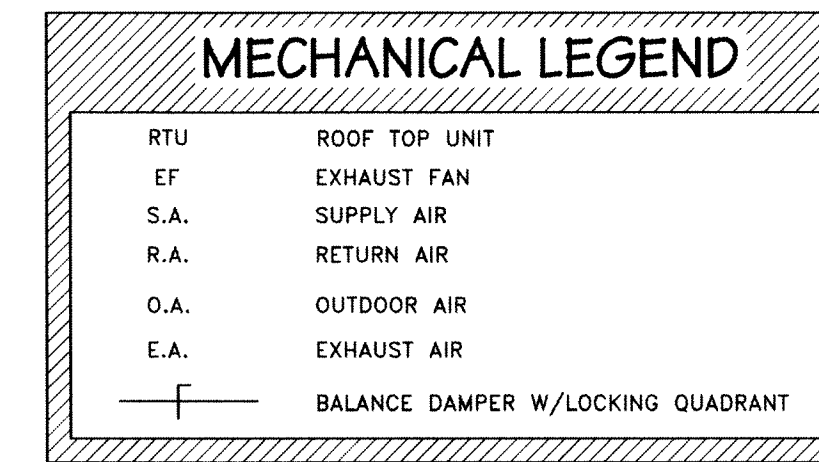

FLOOR PLAN-MECHANICAL

SCALE: 3/16" = 1'-0"

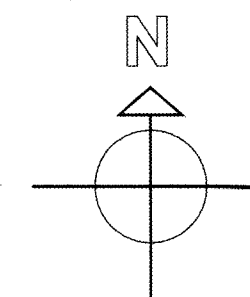

THIS DOCUMENT IS PROTECTED BY COPYRIGHT. COPY ONLY WHEN APPROVED BY THE ENGINEER BY WRITTEN INSTRUMENT.

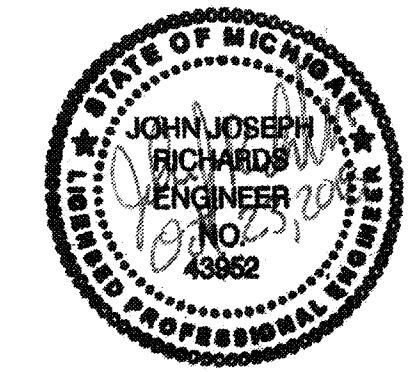

12710 S. WEST BAYSHORE DR.
 SUITE 100
 Traverse City, MI 49684
 (231) 932-0800 Office
 (231) 421-6794 Fax
Apollo Engineering, LLC
 E-Mail: apollo_m_eng@yahoo.com

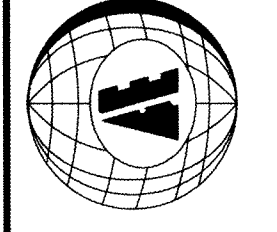

DRAWING TITLE
FLOOR PLAN - MECHANICAL

PROJECT TITLE
 RENOVATION PROJECT FOR:
3960 THIRD STREET
 DETROIT, MI

PROJECT NO.
1807-05

DATE
 JULY 26, 2018
 OCT. 23, 2018

SHEET
M101

THIS DOCUMENT IS PROTECTED BY COPYRIGHT. COPY ONLY WHEN APPROVED BY THE ENGINEER BY WRITTEN INSTRUMENT.

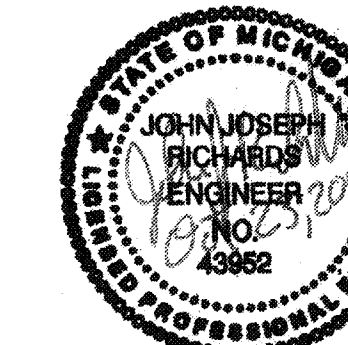

DIFFUSER / GRILLE SCHEDULE

MARK	MODEL No.	CFM	SIZE	BALANCING DAMPER	COLOR	REMARKS
SD-1	TDC	100-120	9"x9", 6"# NECK	NO	WHITE	BORDER TYPE 1, SEE NOTE #4
SR-1	300FL	100	12"x4"	YES	WHITE	SEE NOTES
SR-2	S300FL	210	24"x3 MATCH DUCT DIA	YES	WHITE	SEE NOTES, SCOOP REQUIRED.
RG-1	50F	2250	24"x24"	NO	WHITE	SEE NOTES
TG-1	355FL	-	14"x6"	NO	WHITE	SEE NOTES

NOTES:
 1. BASED ON TITUS.
 2. REVIEW COLOR W/ARCHITECT BEFORE ORDERING.
 3. ALL SUPPLY REGISTERS ON SPIRAL DUCTWORK TO HAVE AIR SCOOP AND TO BE PAINTED TO MATCH DUCTING.
 4. ALL SUPPLY AIR DIFFUSERS SHALL HAVE A 4-WAY AIR PATTERN UNLESS OTHERWISE INDICATED (SEE PLANS).
 5. PROVIDE ALL DUCT COLLARS, TRANSITIONS, CONNECTIONS AND SUPPORTS.
 6. PAINT INSIDE OF DUCT BEHIND REGISTERS AND GRILLES FLAT BLACK.

EXHAUST FAN SCHEDULE

MARK	MODEL No.	CFM @ E.S.P.	RATED SONES	ELECTRICAL	APPROX. WEIGHT	REMARKS
EF-1	FV-05-11VKS1	100 @ 0.10"	0.3	120V, 1# 15.0W	12	BACKDRAFT DAMPER AND WALL CAP.

NOTES:
 1. BASED ON PANASONIC.
 2. FANS TO BE CONTROLLED BY WALL SWITCH AND TIME DELAY OPTION.

ROOF TOP UNIT SCHEDULE

MARK	MANU.	MODEL No.	HTG. MBH INPUT	HTG. MBH OUTPUT	NOMINAL CLG. MBH	CFM	MIN. O.A. CFM	ESP	EAT DB/WB	LAT DB/WB	FAN HP	VOLTAGE	MIN. CIR. AMPACITY	MAX. FUSE SIZE	UNIT WEIGHT
RTU-1	RUUD	RGEDZS150CG22BDA	157.5/225.0	127.5/182.2	146	4500	600	0.8"	76.7/65.9	59.9/58.9	5	208V/3#	75	90	1094

NOTES:
 1. BASED ON RUUD.
 2. PROVIDE MOTORIZED O.A. 3-POSITION DAMPER, W/ ECONOMIZER W/ ENTHALPY SENSOR, 14" ROOF CURB.
 3. ALL UNITS TO HAVE 410A REF.
 4. HEAT EXCHANGERS TO BE STAINLESS STEEL.
 5. TO HAVE MULTIPLE STAGE HEAT AND COOL. SUPPLY FAN TO HAVE VFD.
 6. UNIT TO HAVE FUSED DISCONNECT, POWERED GFI SERVICE RECEPTACLE
 7. UNIT TO BE NATURAL GAS FIRED. UNIT IS TO MEET ASHRAE 0.4% DEHUMIDIFICATION DATA, HEATING TO MEET EXTREME DAILY DRY BULB (MDB -9.8DEG F.)
 8. UNIT TO HAVE 7-DAY PROGRAMMABLE T-STAT.
 9. UNIT TO HAVE MOTOR CONTROLLER TO HAVE HUMIDI-MIZER OPTION.
 10. UNIT TO HAVE SMOKE SENSOR IN RA AIR. TO SHUT DOWN FAN. AS PER CODE.
 11. UNIT TO HAVE MERV 12 FILTERS. MERV 8 PRE-FILTERS.

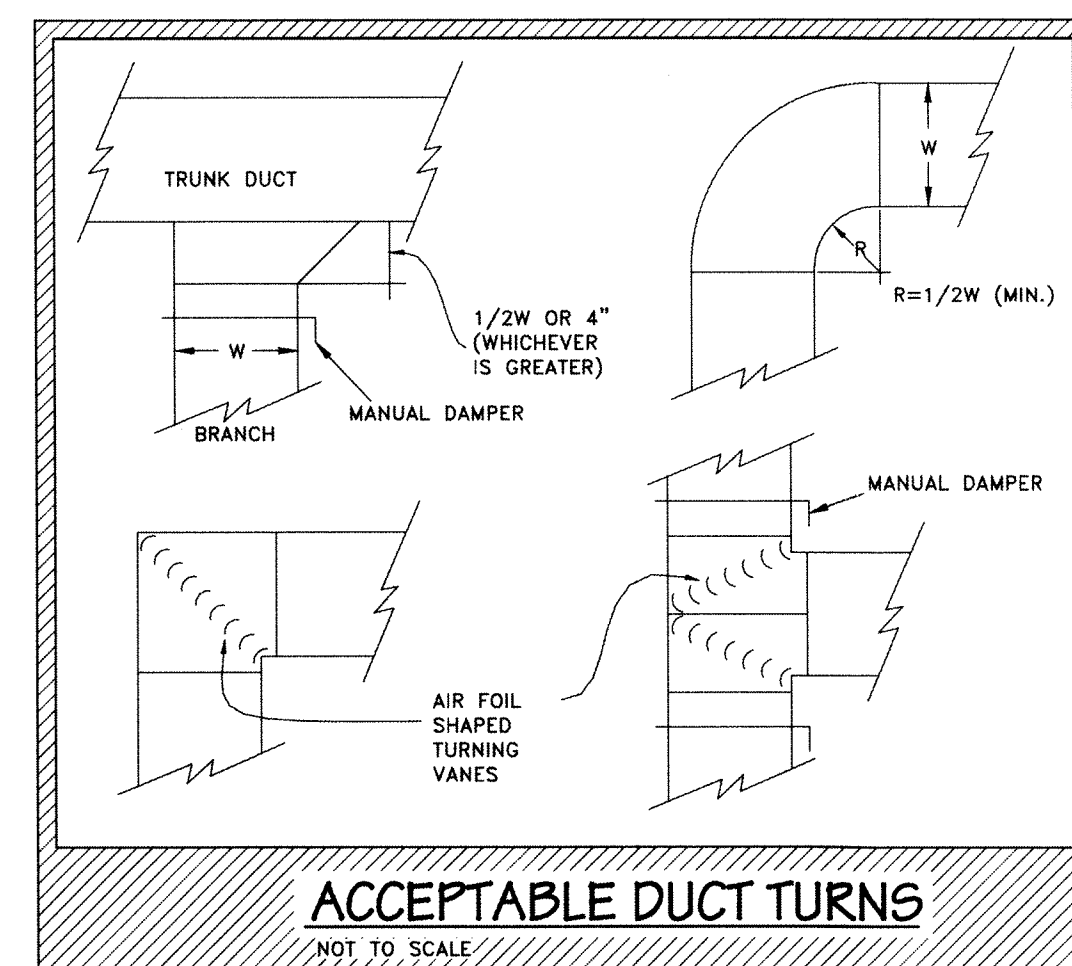
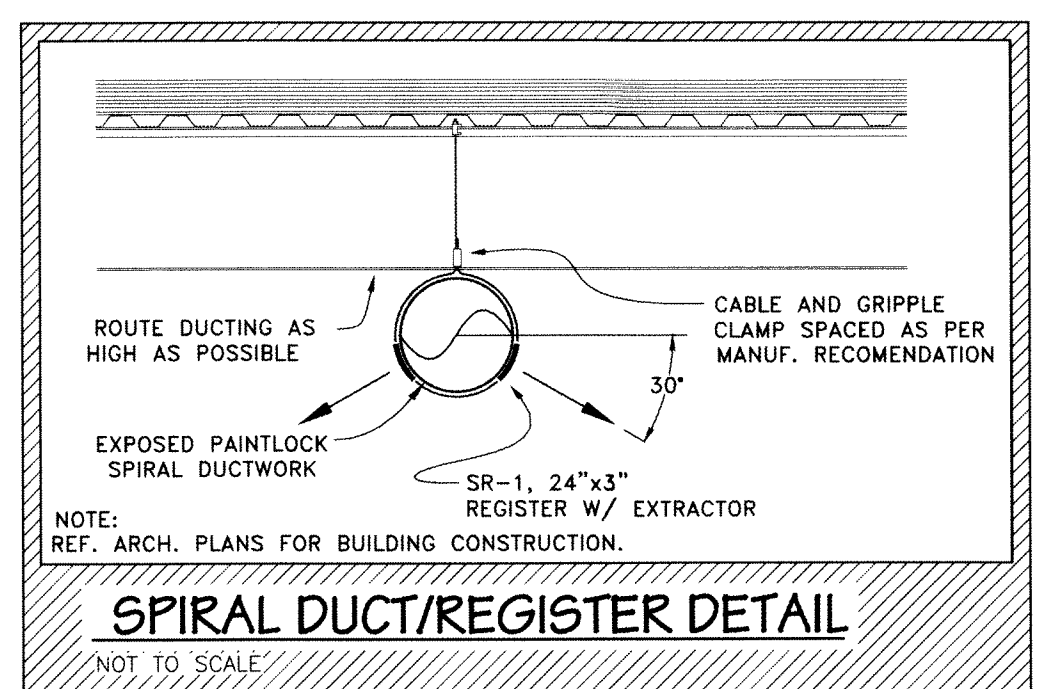
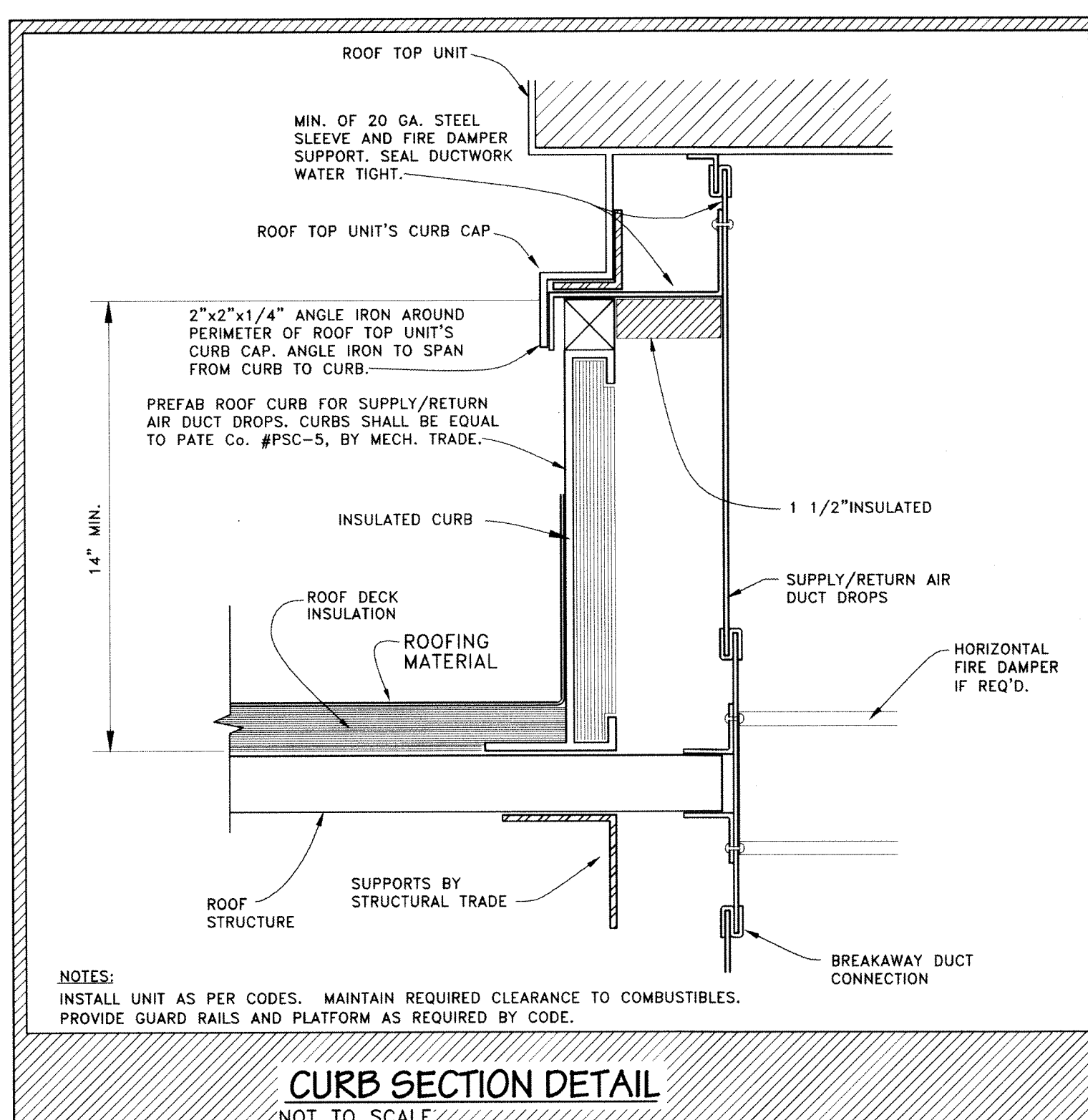
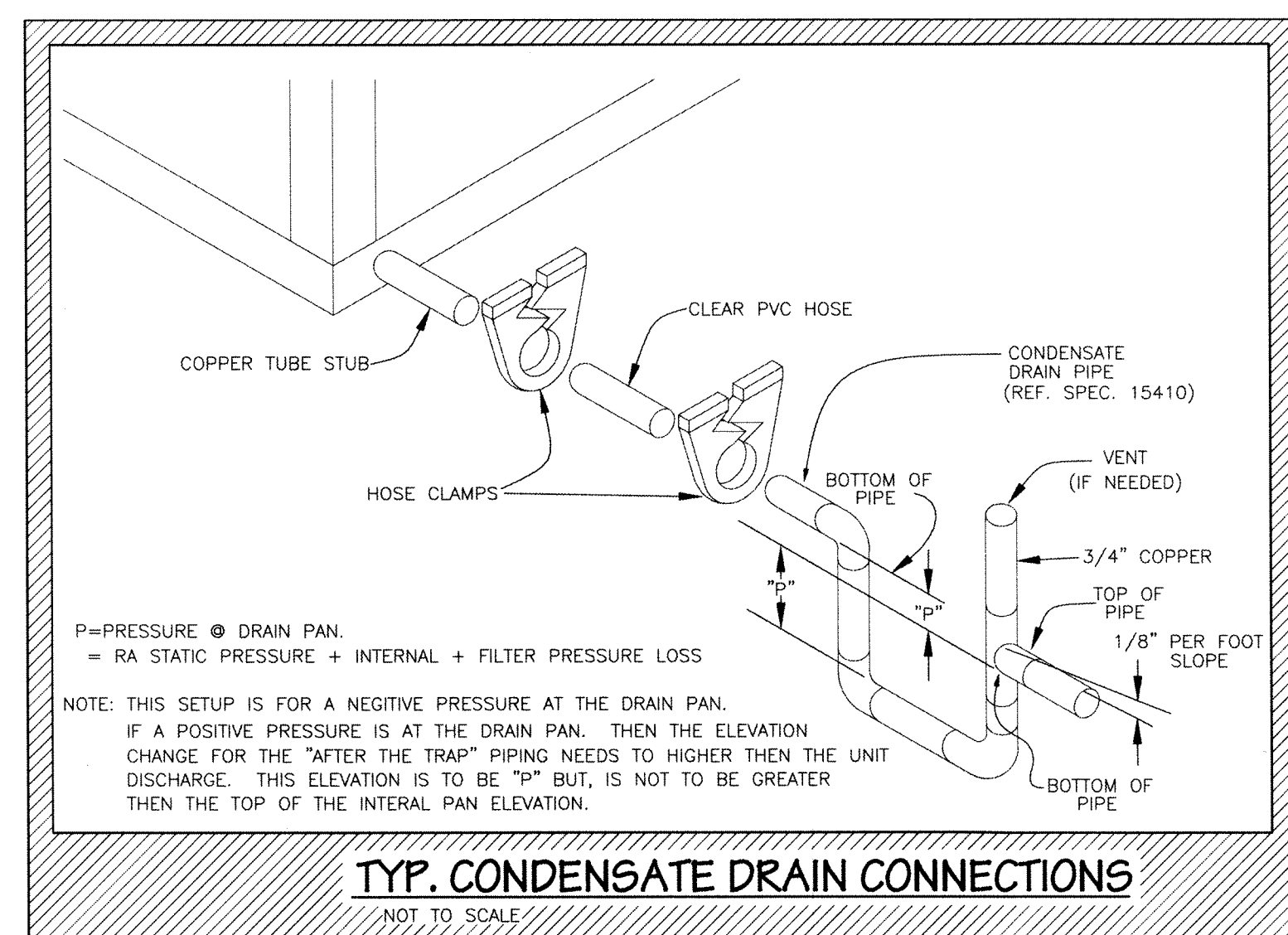

DRAWING TITLE
SCHEDULE/DETAIL - MECHANICAL

PROJECT TITLE
 RENOVATION PROJECT FOR:
3960 THIRD STREET
 DETROIT, MI

PROJECT NO.
 1807-05

DATE
 JULY 26, 2018
 OCT. 23, 2018

SHEET
M201

THIS DOCUMENT IS PROTECTED BY COPYRIGHT. COPY ONLY WHEN APPROVED BY THE ENGINEER BY WRITTEN INSTRUMENT.

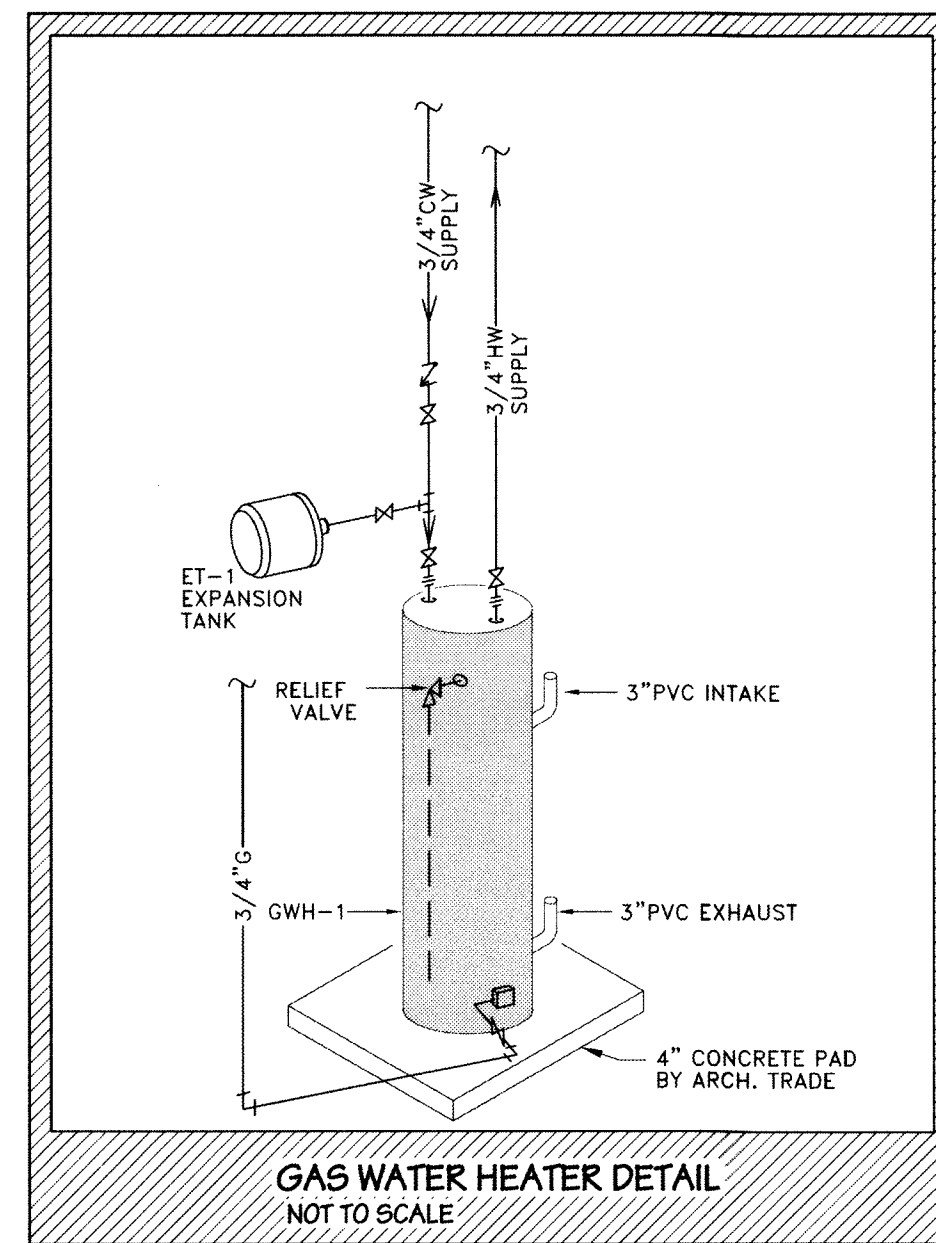

PLUMBING FIXTURE SCHEDULE							
MARK	FIXTURE	MANU.	MODEL	SAN.	HOT	COLD	REMARKS
WC-1	WATER CLOSET	AMERICAN STANDARD	2467.016	4"	-	1"	W/ BEMIS 10SSCT SEAT, 17" HIGH
WC-2	WATER CLOSET	AMERICAN STANDARD	2462.016	4"	-	1"	W/ BEMIS 10SSCT SEAT, 15" HIGH
UR-1	URINAL	AMERICAN STANDARD	6590.503	2"	-	3/4"	W/ FLUSH VALVE
L-1	LAVATORY	AMERICAN STANDARD	0478.403	1 1/2"	-	-	W/ DELTA #520 FAUCET, SEE NOTES #4 & #5
FD-1	FLOOR DRAIN	ZURN	ZN-415-5B	2"S	-	-	W/ TYPE 'B' ROUND STRAINER, SEE NOTE #6
SS-1	SEVICE SINK	FLORESTONE	MSR-2424	1 1/2"	1/2"	1/2"	W/ MR-370 HOSE, MR-371 FAUCET, & MR-372 MOP HANGER
GWH-1	GAS WATER HEATER	AO SMITH	BTX-80	-	3/4"	3/4"	50 GAL, 76,000 BTH/HR.

NOTES:
 1. SEE ARCHITECTURAL DRAWINGS FOR ALL ROUGH-IN LOCATIONS OF PLUMBING FIXTURES.
 2. WC-2 TO CONFORM TO ADA REQUIREMENTS.
 3. VERIFY COLOR WITH ARCHITECT BEFORE ORDERING.
 4. INSULATE ALL EXPOSED SANITARY AND DOMESTIC HOT AND COLD WATER PIPING TO LAVATORIES.
 5. PROVIDE A POWERS 480 MIXING VALVE AT EACH LAV.
 6. PROVIDE A SURE SEAL MODEL #SS2009 TRAP SEALER TO EACH FLOOR DRAIN.

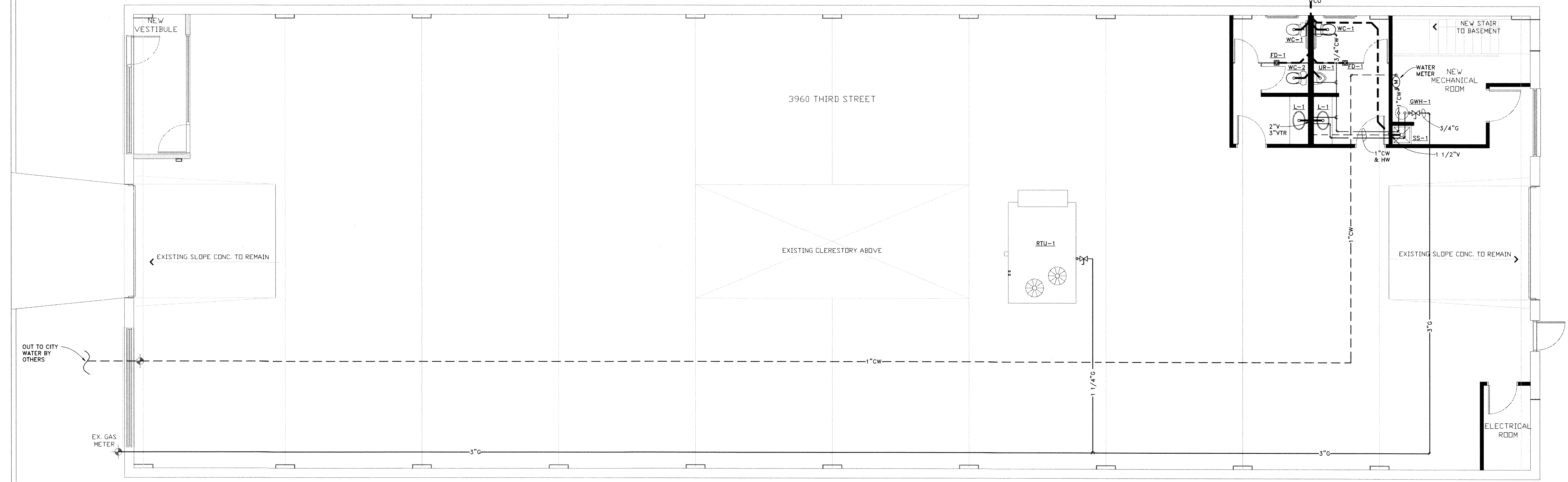

PLUMBING NOTES		
<p>GENERAL NOTES</p> <ol style="list-style-type: none"> ALL CONSTRUCTION AND MATERIALS SHALL CONFORM TO ALL APPLICABLE FEDERAL, STATE AND LOCAL CODES AND REGULATIONS. EACH CONTRACTOR SHALL BE THOROUGHLY KNOWLEDGEABLE OF REGULATIONS GOVERNING HIS PRODUCT AND SERVICE AND SHALL ASSUME RESPONSIBILITY OF INSTALLATION IN ACCORDANCE WITH THOSE REGULATIONS. CONTRACTORS TO VERIFY ALL DIMENSIONS RELATIVE TO THEIR SPECIFIC WORK AND SHALL BE THOROUGHLY FAMILIAR WITH EXISTING CONDITIONS PRIOR TO INITIATING THEIR WORK. DISCREPANCIES SHALL BE REPORTED TO THE CONSTRUCTION MANAGER OR TO HIS ON-SITE REPRESENTATIVE. FAILURE TO DETECT INFERIOR WORK, OR WORK NOT IN ACCORDANCE WITH THESE CONSTRUCTION DOCUMENTS, SHALL NOT BE CONSTRUED AS ACCEPTABLE OF SUCH WORK. ANY PENETRATIONS THROUGH FIRE-RATED ASSEMBLIES FOR MECHANICAL OR PLUMBING SYSTEMS, ETC. SHALL BE FIRE-STOPPED AND DRAFT-STOPPED WITH NON-COMBUSTIBLE MATERIALS PER CODE REQUIREMENTS TO MAINTAIN STRUCTURAL AND FIRE RESISTIVE INTEGRITY. DRAWINGS ARE DIAGRAMMATIC ONLY, FIELD VERIFY EXISTING CONDITIONS. PRIOR TO SUBMITTING A PROPOSAL, BIDDER SHALL HAVE VISITED THE CONSTRUCTION SITE. HE SHALL BE FAMILIAR WITH THE EXISTING CONDITIONS UNDER WHICH HE WILL HAVE TO OPERATE AND WHICH WILL IN ANY WAY AFFECT THE WORK UNDER THIS CONTRACT. NO SUBSEQUENT ALLOWANCE WILL BE MADE IN THIS CONNECTION ON BEHALF OF THE CONTRACTOR FOR ANY ERROR OF NEGLIGENCE ON HIS PART. 	<p>PLUMBING CONSTRUCTION NOTES</p> <p>GENERAL</p> <ol style="list-style-type: none"> REFERENCE ARCHITECTURAL DRAWINGS FOR ALL ROUGH-IN DIMENSIONS, BOTH FIXTURES AND WALLS. ALL VALVES SHALL BE ACCESSIBLE. WATER HAMMER ARRESTORS SHALL BE INSTALLED AND SHALL BE ACCESSIBLE. PLUMBING CONTRACTOR TO EXTEND WATER AND SANITARY LINES AND MAKE UTILITY CONNECTIONS. <p>SPECIFICATIONS</p> <ol style="list-style-type: none"> PLUMBING DESIGN PER LATEST MICHIGAN PLUMBING CODES. 	<ol style="list-style-type: none"> PLUMBING CONTRACTOR SHALL OBTAIN ALL PERMITS, PAY ALL FEES, INCLUDING COSTS ASSESSED BY THE MECHANICAL UTILITY COMPANIES AND ARRANGE FOR ALL INSPECTIONS FOR HIS WORK. AT THE COMPLETION OF PLUMBING WORK, THE PLUMBING CONTRACTOR SHALL FURNISH THE OWNER WITH ALL CERTIFICATES OF FINAL INSPECTION AND APPROVALS. PLUMBING CONTRACTOR SHALL GUARANTEE ALL WORK INSTALLED UNDER HIS CONTRACT TO BE FREE FROM DEFECTIVE WORKMANSHIP AND MATERIALS FOR A PERIOD OF ONE YEAR AFTER THE ACCEPTANCE OF THE BUILDING BY THE OWNER. SHOULD DEFECTS OCCUR WITHIN THIS PERIOD, REPAIR AND/OR REPLACE DEFECTIVE ITEMS AT NO EXPENSE TO THE OWNER. PLUMBING CONTRACTOR SHALL COORDINATE LOCATIONS OF HIS EQUIPMENT AND WORK WITH OTHER BUILDING TRADES TO AVOID ANY INTERFERENCE'S BETWEEN HIS WORK AND OTHER BUILDING TRADES. IF ANY DISCREPANCIES OCCUR, CONSULT WITH THE CONSTRUCTION MANAGER OR HIS ON-SITE REPRESENTATIVE. THE CONTRACTOR SHALL BE HELD FULLY RESPONSIBLE FOR THE PROPER RESTORATION OF ALL EXISTING SURFACES REQUIRING PATCHING, PLASTERING, PAINTING AND/OR OTHER REPAIR DUE TO THE INSTALLATION OF MECHANICAL WORK UNDER THE TERMS OF THIS SPECIFICATION. CLOSE ALL OPENINGS, REPAIR ALL SURFACES, ETC. AS REQUIRED. THE CONTRACTOR SHALL EMPLOY QUALIFIED AND EXPERIENCED WORKMEN FOR THIS WORK. THE PLUMBING CONTRACTOR SHALL PERIODICALLY REMOVE FROM THE SITE ALL DEBRIS AND RUBBISH ACCUMULATING AS A RESULT OF THE MECHANICAL INSTALLATION. UPON COMPLETION OF THE PROJECT, HE SHALL DISPOSE OF ALL DEBRIS AND RUBBISH AND SHALL LEAVE ALL AREAS CLEAN.

FLOOR PLAN - PLUMBING

SCALE: 3/16" = 1'-0"

PLUMBING LEGEND	
---	SANITARY SEWER
- - - -	SANITARY VENT
---	COLD WATER LINE
- - - -	HOT WATER LINE
---	HOT WATER RETURN
○	BALL VALVE

GAS LOAD SCHEDULE		
MARK	EQUIPMENT	GAS LOAD
RTU-1	ROOF TOP UNIT	225,000 BTU/HR
GW-1	GAS WATER HEATER	50,000 BTU/HR
TOTAL GAS LOAD		285,000 BTU/HR



Spray Foam Flat Roofing Composition

GRANULES

The granules increase fire resistance, traction and durability. They will also help to protect the coatings from hail and other damage.

WEATHER PROTECTION

Weather-resistant silicone protects against temperature extremes and ultraviolet rays.



INSULATION BARRIER

Energy-efficient polyurethane foam has an R-Factor of 6.8 per inch, and is water-proof.

GacoFlex S20 Solvent-Free 100% Silicone Coating

USAGE

GacoFlex S20 Series coatings are solvent-free, single-component waterproof elastomeric moisture-curing silicone coatings.

COLORS

S2000 White, S2022 Gray, S2048 Tan

Whether your roof is large or small, flat or sloped, GacoFlex S20 Series Solvent-Free 100% Silicone Roof Coatings provide a proven, guaranteed solution for renewing your weathered and leaking roof. They can be applied to virtually any existing roof to create a durable, glossy, seamless membrane that seals and protects against permanent ponding water, ultraviolet light and severe weather.

GacoFlex S20 is certified to NSF P151, an independent testing protocol for rainwater catchment systems, and found not to impart contaminants that exceed the U.S. Environmental Protection Agency's drinking water regulations or advisories.



GacoFlex[®]
by Gaco Western[®]

S20 Series

The solvent-free alternative to replacing your weathered roof.

WHY CHOOSE SOLVENT-FREE?

GacoFlex solvent-free silicone coatings are made nearly entirely of solids – 95% of what is in the can stays on the roof! The remaining 5% is a specially-formulated curing agent that works by forming a chemical bond between the coating's molecules and sets the coating in place – instead of by the evaporation of harmful solvents into the environment.

Whether your roof is large or small, flat or sloped, GacoFlex S20 Series Solvent-Free 100% Silicone Roof Coatings provide a proven, guaranteed solution for renewing your weathered and leaking roof. They can be applied to virtually any existing roof to create a durable, glossy, seamless membrane that seals and protects against permanent ponding water, ultraviolet light and severe weather. By re-coating, you not only extend the life of your roof, you avoid the need for a time-consuming and costly roof tear-off.

Guaranteed? Yes! All GacoFlex Silicone Roof Coatings carry a 50 Year Limited Material Warranty. In addition, a Labor & Material Warranty is available to Gaco Western Qualified Applicators when GacoFlex S20 Series coating is applied over E5320 2-Part Epoxy Primer/Filler and according to Gaco Western specifications.

GacoFlex S20 Series offers decades of proven performance and protection. **Guaranteed.**



800 456 4226
gaco.com

GacoFlex S20 Series

Solvent-Free 100% Silicone Coating | March 2017

DESCRIPTION	GacoFlex S20 Series coatings are solvent-free, single-component waterproof elastomeric moisture-curing silicone coatings.		
USAGE	<p>GacoFlex S20 Series are ideal for use as a maintenance coating system over pre-existing elastomeric roof coatings, metal roofs, built-up roofing, mineral cap sheet, and weathered single ply membranes (EPDM, PVC, Hypalon®, and TPO/CPA) on a roofing substrate where the membrane surface is in sound condition, but requires a renewal of the membrane surface due to the normal effect of aging and use.</p> <p>A roof coated with GacoFlex S20 Series is ideal for use as part of a rainwater catchment system.</p> <p>GacoFlex S20 Series Coatings are the standard specification for liquid applied silicone coating used in sprayed-in-place polyurethane foam roofing systems.</p> <p>GacoFlex S20 Series Coatings may also be used over concrete, coatings, and over plywood decking when properly applied over an approved base coat; please contact Gaco Western for specific recommendation.</p> <p>When properly applied, the coating system provides a seamless weather-tight seal that protects the substrate from degradation caused by ultraviolet light, water and other normal weathering hazards.</p>		
COLORS	S2000 White, S2022 Gray, S2048 Tan; S2029 Dark Gray (available as special order only)		
APPLIED PRODUCT DATA			
WEATHERABILITY	Excellent durability, color stability and chalk resistance.		
TOXICITY	Not for use in contact with edible substances or long-term potable water storage.		
CHEMICAL RESISTANCE	Excellent solvent and chemical resistance.		
PHYSICAL PROPERTIES	ASTM Test	Result	ASTM D6694 Requirement
Tensile Strength @ 73°F	D412	450 psi	150 min
Elongation at Break @ 73°F	D412	174%	100 min
Tensile Strength @ 0°F	D412	574 psi	150 min
Elongation at Break @ 0°F	D412	169%	100 min
Tear Resistance (Die C)	D624	35.8 lbs/inch	20 min
Crack Bridging - Low Temperature @ -15°F	D522	Pass	Pass
Permeance - 20 mils DFT @ 73°F / 50% RH	E96 - B	5.0 Perms	2.5 min
Wet Adhesion			
Spray Polyurethane Foam	C794 / D903	Pass	2.0 min
Acrylic Coating	C794 / D903	Pass	2.0 min
Galvanized Metal with E5320 Primer	C794 / D903	Pass	2.0 min
BUR with E5320 Primer	C794 / D903	Pass	2.0 min
EPDM with E5320 Primer	C794 / D903	Pass	2.0 min
PVC with E5320 Primer	C794 / D903	Pass	2.0 min
GacoFlex S2000 (white) meets the cool roof requirements of California Title 24 and the International Energy Conservation Code.			
8,670 Hour Immersion in 150°F Water	D471	Not Required	
Tensile Strength	D412	450 psi	Not Required
Elongation at Break	D412	125%	Not Required
1000 Hrs. Accelerated Weathering	G154		
Elongation at Break @ 73°F	D412	371%	100 min
Elongation at Break @ 0°F	D412	124%	100 min
5000 Hrs. Accelerated Weathering	G154		
Elongation at Break @ 73°F	D412	126%	Min 50%
Elongation at Break @ 0°F	D412	124%	Min 50%
Appearance	D6694	Pass	No Cracking or Checking
SOLAR PERFORMANCE	ASTM Test	Initial	
Solar Reflectance	C1549	0.88	
Thermal Emittance	C1371	0.87	
Solar Reflectivity Index (SRI)	E1980	111	
PACKAGED PRODUCT DATA			
THEORETICAL COVERAGE	1.5 gallons per 100 sq. ft. to yield approximately 22 dry mils. NOTE: Application rate is job specific and losses due to overspray, surface profile, and wind may occur. Additional material may be required to achieve 22 dry mils.		
SOLIDS	Weight: 96.5% (Method 4041 - Fed. Std. 141) / Volume: 95%		
VOC	37 g/l (0.309 lb/gal)		
FLASH POINT	ASTM D3278	178°F (81°C)	
STORAGE STABILITY	Two years from date of manufacture when stored in sealed containers between 0°F - 80°F (-17°C - 26°C).		
APPLICATION			
MIXING	Mix before application to ensure uniform color and consistency.		
THINNING	Product should not be thinned.		
ASPHALT ROOFING SEALER	As an option to help inhibit bleed-through on asphaltic and bitumen-containing substrates, first apply 1 coat of GacoFlex A4207 BleedTrap Sealer for Asphalt Roofing at a rate of 100 sq. ft. per gallon to yield 8 dry mils.		
PRIMER	Existing silicone coatings should not be primed. On all other substrates, apply GacoFlex E5320 2-Part Epoxy Primer/Filler according to label directions.		
APPLICATION	<p>Apply by brush or 3/4" nap woven roller as received. For spray application, use as received; consult Gaco Western's Silicone Spray Guide SG-Silicone for more information. For cold weather application, keep material stored above 65°F (18°C). Do not apply if rain is expected within 1 hour. For application in temperatures below freezing or above 120°F (49°C), contact Gaco Western.</p> <p>On smooth surfaces, apply one coat at the rate of 1.5 gallons per 100 square feet to achieve approximately 22 dry mils. On granulated and other rough surfaces, apply two separate coats at the rate of 1 gallon per 100 square feet per coat. Allow first coat to dry a minimum of 4 hours at 55°F (13°C) or higher, or until it can be safely walked on (product is moisture cure, low humidity will result in longer dry times); recoat within 4 to 48 hours.</p> <p>Coat all surfaces including expansion joint covers and flashings. Extra material is required at all edges and penetrations if neoprene sheet flashing is not used.</p> <p>NOTE: Application rate is job-specific and losses due to overspray, surface profile and wind may occur. Additional material may be required to achieve 22 dry mils.</p>		
DRY TIME	Final coat should be allowed to cure 24 to 48 hours, depending on temperature and humidity, before suitable for light foot traffic.		
CLEAN UP	Clean application tools and equipment with GacoFlex Silicone Solvent. Recirculate through lines and gun until residual coating is removed. DO NOT USE WATER OR RECLAIMED SOLVENTS.		
For specific Safety and Health information please refer to Safety Data Sheet.			

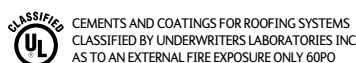

*Applies only to S2000 (white)

Gaco Western
SINCE 1955

gaco.com | 800 456 4226

November 15, 2018

3960 Third St. - White Box

BUILDING PERMIT APPLICATION CITY OF DETROIT

BUILDINGS, SAFETY ENGINEERING & ENVIRONMENTAL DEPARTMENT

2 WOODWARD AVENUE, ROOM 409, DETROIT, MICHIGAN 48226

Date * 11/06/2018 00:00

Property Information COMPLETE

Address * 3960 Third St.

Floor * 1

Suite #

Stories * 1

AKA

Lots

Subdivision

Parcel ID#(s) 003403 Ward 04

Total Acres

Lot Width N/A

Lot Depth

Current Legal Use of Property *

Proposed Use *

Are there any existing buildings or structures on this parcel?

Yes
 No

Project Information COMPLETE

Permit Type *

If Other: *

If Revision (original permit has been issued and is active) *

Description of Work (Describe in detail proposed work and use of property, attach work list) *

MBC Use Change

Yes
 No

Included Improvements (Check all applicable; these trade areas require separate permit applications)

- HVAC/Mechanical
- Electrical
- Plumbing
- Fire Sprinkler System
- Fire Alarm

Structure Type *

If Other *

Size of Structure to be Demolished (LxWxH) in cubic feet

Construction involves changes to the floor plan? (e.g. interior demolition or constructing new walls)

Yes
 No

Use Group *

Type of Construction (per current MI Bldg Code Table 601) *

Estimated Cost of Construction \$ By Contractor

496838.00

Estimated Cost of Construction \$ By Department Structure Use

Residential-Number of Units

0 *

Provide Number of Residential Units

Office-Gross Floor Area

0 *

Provide Gross Floor Area of Office

Industrial-Gross Floor Area

0 *

Provide Industrial Gross Floor Area

Commercial-Gross Floor Area

0 *

Provide Commercial Gross Floor Area

Institutional-Gross Floor Area

0 *

Provide Institutional Gross Floor Area

Other-Gross Floor Area

0 *

Provide Other Gross Floor Area

Proposed no. of employees

0

List materials to be stored in the building

N/A

PLOT PLAN SHALL BE submitted on separate sheets and shall show all easements and measurements (must be correct and in detail).

SHOW ALL streets abutting lot, indicate front of lot, show all buildings, existing and proposed distances to lot lines.

Health- Food SafetyCOMPLETE

Are you planning on serving and/or selling any food or beverage? * Yes No

If you answered "Yes" to the question above, please click [HERE](#) to review, complete and attach all the required Health related plans and documents.

Building Permit Application RequestCOMPLETE

The City of Detroit offers its customers the ability to pay for the Building Permit at the time their Plan Review applications are submitted.

[Building Permit and Plan Review fees will have to be paid in full prior for the review process to begin if this service is requested.](#)

Would you like to request Building Permit Fee to be paid along with the Plan Review Fees? * Yes No

Identification (All Fields Required)COMPLETE

Property Owner/Homeowner is Permit Applicant * No ▼

Contractor is Permit Applicant * Yes ▼

Tenant or Business Occupant is Permit Applicant * No ▼

Architect/Engineer/Consultant is Permit Applicant * No ▼

Property Owner/Homeowner is Permit Applicant (optional)

Homeowner Affidavit (optional)

Contractor is Permit ApplicantCOMPLETE

Representative Name * W.C.C.I. - Wilson Company Contractors, Inc.

Company Name * Gary Wilson

Address * 2790 Island View Rd.

City * Traverse City

State * MI Michigan ▼

Zip * 49686

Phone (734) 661-5943

Mobile * (734) 604-0977

Email * carlson@3missionpartners.com

Driver's License# * 0000

Driver's License Expiration Date * 11/06/2018 00:00

Property Owner Name * Selden AA Third Street Garage, LLC

Property Owner Address * 3075 Charlevoix Dr., Ste. 100 - Grand Rapids, MI 49686

Property Owner Phone Number * (231) 620-0136

Property Owner Email * gwilsonwcci@gmail.com

Tenant or Business Occupant is Permit Applicant (optional)

Architect/Engineer/Consultant is Permit Applicant (optional)

SignatureINCOMPLETE



Applicant: Ann Phillips

Signature date:

[Home](#) | [Profile](#)

December 18, 2019

CERTIFICATE OF APPROPRIATENESS

Bob George
24936 Crocker Blvd
Harrison Township MI 48045

RE: Application Number 19-6538; 3960 Third; Willis-Selden Historic District

Dear Mr. George,

At the regular scheduled meeting that was held on December 11, 2019, the Detroit Historic District Commission ("Commission") reviewed the above-referenced application for building permit. Pursuant to Section 5(10) of the Michigan Local Historic District Act, as amended, being MCL 399.205, MSA 5-3407(5)(10) and Section 21-2-73 of the 2019 Detroit City Code; the Commission reviewed the above-referenced application for building permit and hereby issues a Certificate of Appropriateness, which is effective as December 18, 2019.

The Commission issued a Certificate of Appropriateness for the following work items because they meet the Secretary of Interior's Standards for Rehabilitation #2) *The historic character of a property shall be retained and preserved. The removal of historic materials or alteration of features and spaces that characterize a property shall be avoided and #9) New additions, exterior alterations, or related new construction shall not destroy historic materials that characterize the property. The new work shall be differentiated from the old and shall be compatible with the massing, size, scale, and architectural features to protect the historic integrity of the property and its environment.*

West/Front Elevation

- The applicant proposes to repaint the elevation a warm gray (Benjamin Moore, Chelsea Gray, HC-168). The color is close to B:10 - Grayish Green.
- The brick in the two openings will be removed and black aluminum storefronts, with insulated glass, will be installed. New limestone panels and limestone sills will be installed below the storefronts (replacing the existing brick).
- The right-side opening will have two, 2-panel fold-in units, creating four equal glass areas. Four fixed windows will be installed above the doors, with a continuous horizontal mullion separating the openings.
- The left-side opening will also be divided into four units. The right half will feature a 2-panel, fold-in unit with fixed glass above. The left half will feature 3'-0" x 8'-0" black aluminum door (glass panel) and a fixed side window, with two fixed glass windows above. The floor plan shows the door/side window to be recessed approximately seven feet from the front elevation.

East/Rear Elevation

- The rear elevation will include a 3'-0" x 7'-0" black aluminum door (with glass panel), an aluminum insulated glass roll-up door, and glass block fill an existing window opening that was previously bricked-in. Damaged brick and clay coping will be replaced with new materials to match existing.

Side Elevations (North/South)

- The side elevations, will be inspected and approximately 40% of the existing brick will be replaced with new brick (same color and texture).

Roof and All Elevations

- Existing torch down roof to be removed; a new energy shield roof to be installed (color change from black to beige).
- Clerestory, which from the aerial looks to be currently covered, will receive three storefront windows on each side. Hardie Panels to be installed on remaining walls.
- Fascia to be replaced; brown aluminum gutters and white pvc downspouts (which return into the building) will be reconnected.
- All of the glass within the doors and storefronts will be clear.

The project was approved with the following conditions:

- The existing condition and long-term care of the masonry side walls be investigated further with a detailed repair plan per the recommendations of a licensed mason.
- New brick shall match the existing brick in color, dimension, texture and pattern. A historic mortar mix shall be used, even if new brick (rather than reclaimed historic brick) is used. Please refer to the National Park Service Technical Preservation Services Preservation Brief "*Repointing Mortar Joints in Historic Masonry Buildings*".
- The left-side storefront design will match the floor plan indicated on the mechanical/electrical/plumbing plans, i.e., the door and window unit will be flush with the storefront folding units.
- The brick below the sills will remain. Additionally, the brick removed from the area where the new door will be constructed will be saved and reused, as is possible, to fill in the area below the sill that will be enclosed upon the removal of the existing door.
- A catalog cut confirming the style of glass block will be submitted.
- A cut sheet confirming the Hardie Panels (design, finish and color) will be submitted.
- Specifications for the clerestory storefront windows will be submitted.
- The silicone applied to the Energy Shield spray foam roof will be gray (S2022).
- The above items will be submitted for staff review. Should staff determine that such changes are not consistent with the Commission's intent, such changes shall be deemed a new application for formal Commission review at the next available meeting.

Please retain this COA for your files. Once HDC staff has granted its final approval, you can proceed to the City of Detroit Buildings, Safety, Engineering and Environmental Department. It is important to note that approval by the Detroit Historic District Commission does not waive the applicant's responsibility to comply with any other applicable ordinances or statutes. If you have any questions regarding the foregoing, please contact me at 313-628-2190.

For the Commission:



Audra Dye
Staff, Historic District Commission

