

December 22, 2020

CERTIFICATE OF APPROPRIATENESS

Scott Lowell
701 W. Canfield
Detroit, MI 48216

RE: Application Number 20-6988; 701 W. Canfield; West Canfield Historic District

Dear Mr. Lowell:

At the special meeting that was held on December 16, 2020, the Detroit Historic District Commission (“Commission”) reviewed the above-referenced application for building permit. Pursuant to Section 5(10) of the Michigan Local Historic District Act, as amended, being MCL 399.205, MSA 5-3407(5)(10) and Section 21-2-73 of the 2019 Detroit City Code; the Commission has reviewed the above-referenced application for building permit and hereby issues a Certificate of Appropriateness, which is effective as December 22, 2020.

The Commission issued a Certificate of Appropriateness for the following work items listed as well as those shown in the attached drawings because they meet the Secretary of Interior’s Standards for Rehabilitation.

Exterior Work

- Replace existing vinyl and wood windows with aluminum clad wood windows at the North (Front), East and West elevations.

The Certificate of Appropriateness is issued with the following conditions:

- The brick mold identified in the drawings be retained. If areas of the brick mold have deteriorated beyond repair, the applicant may replace with in-kind material, per staff review of replacement confirming match in material, profile, and dimension.
- The wood mullions at the windows are retained.

Please retain this COA for your files. You should now proceed to obtain a building permit from the City of Detroit Buildings, Safety, Engineering and Environmental Department. It is important to note that approval by the Detroit Historic District Commission does not waive the applicant's responsibility to comply with any other applicable ordinances or statutes.

For the Commission:



Daniel Rieden
Staff
Detroit Historic District Commission

THIS IS A 3-PAGE FORM - ALL INFORMATION IS REQUIRED FOR PROJECT REVIEW

HISTORIC DISTRICT COMMISSION PROJECT REVIEW REQUEST

City of Detroit - Planning & Development Department
2 Woodward Avenue, Suite 808
Detroit, Michigan 48226

Date: 12.07.2020

PROPERTY INFORMATION

ADDRESS: 701 West Canfield AKA:

HISTORIC DISTRICT: West Canfield

SCOPE OF WORK: Windows/Doors Roof/Gutters/Chimney Porch/Deck Landscape/Fence/Tree/Park General Rehab
(Check ALL that apply) New Construction Demolition Addition Other:

APPLICANT IDENTIFICATION

Property Owner/Homeowner Contractor Tenant or Business Occupant Architect/Engineer/Consultant

NAME: Scott Lowell COMPANY NAME: 701 W Canfield LLC

ADDRESS: 701 West Canfield CITY: Detroit STATE: MI ZIP: 48201

PHONE: MOBILE: 313-610-8086 EMAIL: scott@trafficjam.com

PROJECT REVIEW REQUEST CHECKLIST

Please attach the following documentation to your request:

PLEASE KEEP FILE SIZE OF ENTIRE SUBMISSION UNDER 30MB

- Completed Building Permit Application (highlighted portions only)
- ePLANS Permit Number (only applicable if you've already applied for permits through ePLANS)
- Photographs of ALL sides of existing building or site
- Detailed photographs of location of proposed work (photographs to show existing condition(s), design, color, & material)
- Description of existing conditions (including materials and design)
- Description of project (if replacing any existing material(s), include an explanation as to why replacement--rather than repair--of existing and/or construction of new is required)
- Detailed scope of work (formatted as bulleted list)
- Brochure/cut sheets for proposed replacement material(s) and/or product(s), as applicable

NOTE:

Based on the scope of work, additional documentation may be required.

See www.detroitmi.gov/hdc for scope-specific requirements.

Upon receipt of this documentation, staff will review and inform you of the next steps toward obtaining your building permit from the Buildings, Safety Engineering and Environmental Department (BSEED) to perform the work.

SUBMIT COMPLETED REQUESTS TO HDC@DETROITMI.GOV

AKA: _____ Lot(s): _____ Subdivision: _____
Parcel ID#(s): 04000902 Total Acres: 0.171 Lot Width: 50' Lot Depth: 150'
Current Legal Use of Property: residential Proposed Use: residential
Are there any existing buildings or structures on this parcel? Yes No

PROJECT INFORMATION

Permit Type: New Alteration Addition Demolition Correct Violations
 Foundation Only Change of Use Temporary Use Other: _____
 Revision to Original Permit #: _____ (Original permit has been issued and is active)

Description of Work (Describe in detail proposed work and use of property, attach work list)
Replace existing vinyl and wood windows with clad wood windows. See attached scope.

MBC use change No MBC use change

Included Improvements (Check all applicable; these trade areas require separate permit applications)
 HVAC/Mechanical Electrical Plumbing Fire Sprinkler System Fire Alarm

Structure Type
 New Building Existing Structure Tenant Space Garage/Accessory Building
 Other: _____ Size of Structure to be Demolished (LxWxH) _____ cubic ft.
Construction involves changes to the floor plan? Yes No

(e.g. interior demolition or construction to new walls)
Use Group: R-2 Type of Construction (per current MI Bldg Code Table 601) III-B

Estimated Cost of Construction \$ _____ By Contractor \$ _____ By Department

Structure Use
 Residential-Number of Units: 7 Office-Gross Floor Area _____ Industrial-Gross Floor Area _____
 Commercial-Gross Floor Area: _____ Institutional-Gross Floor Area _____ Other-Gross Floor Area _____
Proposed No. of Employees: _____ List materials to be stored in the building: _____

PLOT PLAN SHALL BE submitted on separate sheets and shall show all easements and measurements (must be correct and in detail). SHOW ALL streets abutting lot, indicate front of lot, show all buildings, existing and proposed distances to lot lines. (Building Permit Application Continues on Next Page)

For Building Department Use Only

Intake By: _____ Date: _____ Fees Due: _____ DngBld? No

Permit Description: _____

Current Legal Land Use: _____ Proposed Use: _____
Permit#: _____ Date Permit Issued: _____ Permit Cost: \$ _____
Zoning District: _____ Zoning Grant(s): _____
Lots Combined? Yes No (attach zoning clearance)

Revised Cost (revised permit applications only) Old \$ _____ New \$ _____

Permit #:

Phone: _____ Mobile: 313-610-8086

Driver's License #: _____ Email: scott@trafficjam.com

Contractor Contractor is Permit Applicant

Representative Name: _____ Company Name: _____

Address: _____ City: _____ State: _____ Zip: _____

Phone: _____ Mobile: _____ Email: _____

City of Detroit License #: _____

TENANT OR BUSINESS OCCUPANT Tenant is Permit Applicant

Name: _____ Phone: _____ Email: _____

ARCHITECT/ENGINEER/CONSULTANT Architect/Engineer/Consultant is Permit Applicant

Name: Nicole Rittenour State Registration#: 1301062110 Expiration Date: 10/2021

Address: 2255 Wabash City: Detroit State: MI Zip: 48216

Phone: 313-757-5006 Mobile: 313-580-8178 Email: nikki@pushdetroit.com

HOMEOWNER AFFIDAVIT (Only required for residential permits obtained by homeowner.)

I hereby certify that I am the legal owner and occupant of the subject property and the work described on this permit application shall be completed by me. I am familiar with the applicable codes and requirements of the City of Detroit and take full responsibility for all code compliance, fees and inspections related to the installation/work herein described. I shall neither hire nor sub-contract to any other person, firm or corporation any portion of the work covered by this building permit.

Print Name: _____ Signature: _____ Date: _____
(Homeowner)

Subscribed and sworn to before me this _____ day of _____ 20 ____ A.D. _____ County, Michigan

Signature: _____ My Commission Expires: _____
(Notary Public)

PERMIT APPLICANT SIGNATURE

I hereby certify that the information on this application is true and correct. I have reviewed all deed restrictions that may apply to this construction and am aware of my responsibility thereunder. I certify that the proposed work is authorized by the owner of the record and I have been authorized to make this application as the property owner(s) authorized agent. Further I agree to conform to all applicable laws and ordinances of jurisdiction. **I am aware that a permit will expire when no inspections are requested and conducted within 180 days of the date of issuance or the date of the previous inspection and that expired permits cannot be**

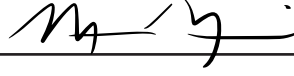
Print Name: Nicole Rittenour Signature:  Date: 12.07.202
(Permit Applicant)

Driver's License #: R356630585091 Expiration: 2-03-2022

Subscribed and sworn to before me this _____ day of _____ 20 ____ A.D. _____ County, Michigan

Signature: _____ My Commission Expires: _____
(Notary Public)



December 7, 2020

701 W Canfield

PROJECT INFORMATION

Description of Existing Conditions

This project site is located in the West Canfield Historic District listed on the U.S. National Register of Historic Places. It is a 3-story structure plus basement. The original building was a residential duplex. The roof is a cross-gable structure with a rear hip-framed structure. The plan incorporates window bays on the east and west elevations. The front facade features a covered porch.

The exterior of the building is masonry bearing wall construction at the basement through second stories. The third floor (attic) is framed primarily in wood and clad with a combination of wood trim, and stucco. **The masonry repairs and roof trim are part of a previous submission (a COA was issued on 5/21/2020 under application number 20-6624).**

Description of Work

Renovation of existing historic 3-story duplex building plus basement. Building improvements include new windows.

NORTH ELEVATION (FRONT):

A. REPLACE (8) EXISTING VINYL DOUBLE-HUNG WINDOWS WITH CLAD WOOD DOUBLE-HUNG INSERT WINDOWS.

B. REPLACE (8) EXISTING WOOD DOUBLE-HUNG WINDOWS WITH CLAD WOOD DOUBLE-HUNG INSERT WINDOWS.

C. REPLACE (2) VINYL CASEMENT WINDOWS WITH (1) FRENCH INSWING CASEMENT CLAD WOOD WINDOW.

D. REPLACE (1) WOOD FRENCH INSWING CASEMENT WINDOW WITH A CLAD WOOD FRENCH INSWING CASEMENT WINDOW.

E. REPLACE (1) VINYL SLIDING WINDOW WITH (1) CLAD WOOD CASEMENT WINDOW AT BASEMENT.

F. REPLACE (2) WOOD CASEMENT WINDOWS WITH CLAD WOOD CASEMENT WINDOWS AT BASEMENT.

EAST ELEVATION:

A. REPLACE (7) VINYL SLIDING WINDOWS WITH (7) CLAD WOOD CASEMENT WINDOWS AT BASEMENT. REMOVE METAL GRILLS AT EACH WINDOW.

B. REPLACE (12) EXISTING VINYL DOUBLE-HUNG WINDOWS WITH CLAD WOOD DOUBLE-HUNG INSERT WINDOWS.

C. REPLACE (2) EXISTING VINYL CASEMENT WINDOWS WITH (2) CLAD WOOD DOUBLE-HUNG INSERT WINDOWS.

D. REPLACE (1) EXISTING VINYL CASEMENT WINDOW WITH (1) CLAD WOOD CASEMENT INSERT WINDOW.

SOUTH ELEVATION (REAR):

NO WORK PROPOSED AT THIS AREA

WEST ELEVATION:

A. REPLACE (6) WOOD CASEMENT WINDOWS WITH CLAD WOOD CASEMENT WINDOWS AT BASEMENT.

B. REPLACE (12) EXISTING WOOD DOUBLE-HUNG WINDOWS WITH CLAD WOOD DOUBLE-HUNG INSERT WINDOWS.

C. REPLACE (2) EXISTING WOOD CASEMENT WINDOWS WITH (2) CLAD WOOD CASEMENT WINDOWS.

D. REPLACE (1) EXISTING WOOD CASEMENT WINDOW WITH (1) CLAD WOOD CASEMENT WINDOW.

12/3/2020

Mr. Scott Lowell
Attn: Project Manager
630 Woodward Ave.
Detroit, MI. 48226
Phone: 313-610-8086
Email: scott@traffic-jam.com

Job Name: 701 W. Canfield
Job Location: Detroit, MI

HISTORIC WINDOW SITE REVIEW:

The following is the Historic Window Site Review as requested for the property at 701 W. Canfield in downtown Detroit, MI. This includes a review of all window openings on all elevations for this 3-story building. This review is based a site visit by Mike Shields of BlackBerry, and discussions with Mr. Scott Lowell. We also have reviewed the prepared plans by PUSH Design LLC, detailing the proposed renovation as well as window replacement. We have noted our review and confirmation of the window details as shown on pages H.19, H.20, and H.21. It is our understanding this property is in the historic district and must have HDC approval, as well as the Owner's possible interest in Federal Historic Tax Credits. Our review considers the National Park Service guidelines for restoration and replication as provided in the Wood Window Preservation NPS Brief #9. Likewise, in providing our recommendation for the restoration or replacement we are adhering to the guidelines that meet NPS and SHPO standards. Please note this review is our opinion based on over 30 years of historic window restoration and replication experience; however, you must have written approval from NPS to be assured of the project's approval; as well as approval by your local HDC prior to proceeding with construction.

Existing Conditions: The structure has (54) window openings including the basement, 1st Floor, 2nd Floor, and 3rd Floor levels. The original windows were wood double hung, picture, and casement configuration, with a wood exterior brick mould, sill, and blind stop. All windows were painted both on the interior and exterior surface. All windows were glazed with 1/4" annealed float glass with an exterior putty glazing compound. In our interior and exterior inspection about 20 % of the windows had either interior or exterior board up which deterred full viewing of the condition. We did remove a sampling of the board up and in all cases found the window components to be in "poor" condition. The windows on the east half of the structure on the 1st, 2nd, and 3rd Floors have all been replace with vinyl replacement windows. The original wood sashes

including parting bead, and sash trim was removed and disposed of; the vinyl windows have a 3 ¼" frame depth and were set, screwed, and caulked into the old master frame. This was poorly done, and many of the main frames were damaged including being split and cracked making them unusable in a restoration application. The windows in this area of the structure account for approximately 40% of the openings in the building.

In the West half of the structure the windows are the original wood windows, except the casement windows on the east and west slope roof dormers. These appear to have been replaced in the last 30 years with a wood clad product, they are in poor working condition. The rest of the existing windows are in poor condition especially the exterior sills, and the corner joinery at the jamb and sill connection. The majority of the exterior sills are open grained, fissured, and need full replacement. Many sashes are missing, approximately 20%. Most have failed joinery at the meeting rail, or bottom rail and stile mortised joinery. The existing windows have not been maintained and have been allowed to be open to the weather that has warped and twisted sash and frame components.

Recommendation: Considering the fact the 40% of the windows were replaced with a very low-quality vinyl window; this alone should confirm the need to replace with a replica window product. Likewise, the remaining windows are in "very poor condition" and would not allow for a viable restoration. Water saturation, failed joinery, the need to fully replace over 30% of all exterior sills, all point to the need for a fully replication of the original product. I would suggest an aluminum clad wood or a thermally broken aluminum replica window. In this residential setting my opinion would the aluminum clad wood window would be fit this property. The new product would include AAMA 2604 finish, clear pine interior, insulated glass with low-e/argon, exterior brick mould casing, and a beveled exterior sash design. The estimated cost for replacement would be \$155,000.00

Please let me know if you need any additional information.

Sincerely,

MKS
Michael K. Shields
President
BlackBerry Systems, Inc.

12/3/2020
Date

Note: See the following page for supporting photos

SUPPORTING PHOTOS



Front Elevation of 701 W. Canfield



Rear Elevation of 701 W. Canfield



1st Floor East Elevation, vinyl window replaced original sash



1st floor window, viewable sill condition - poor



Front Elevation, 1st Floor, Typical view vinyl replacement windows

Typical Condition of Existing Wood Windows on West side of structure



Failed Corner Joinery, Bottom Rail



Failed Sash Joinery



Rotted jamb behind board-up that was removed



Spilt Jamb Frame

PROPOSED WINDOW REPLACEMENT TO 701 W. CANFIELD

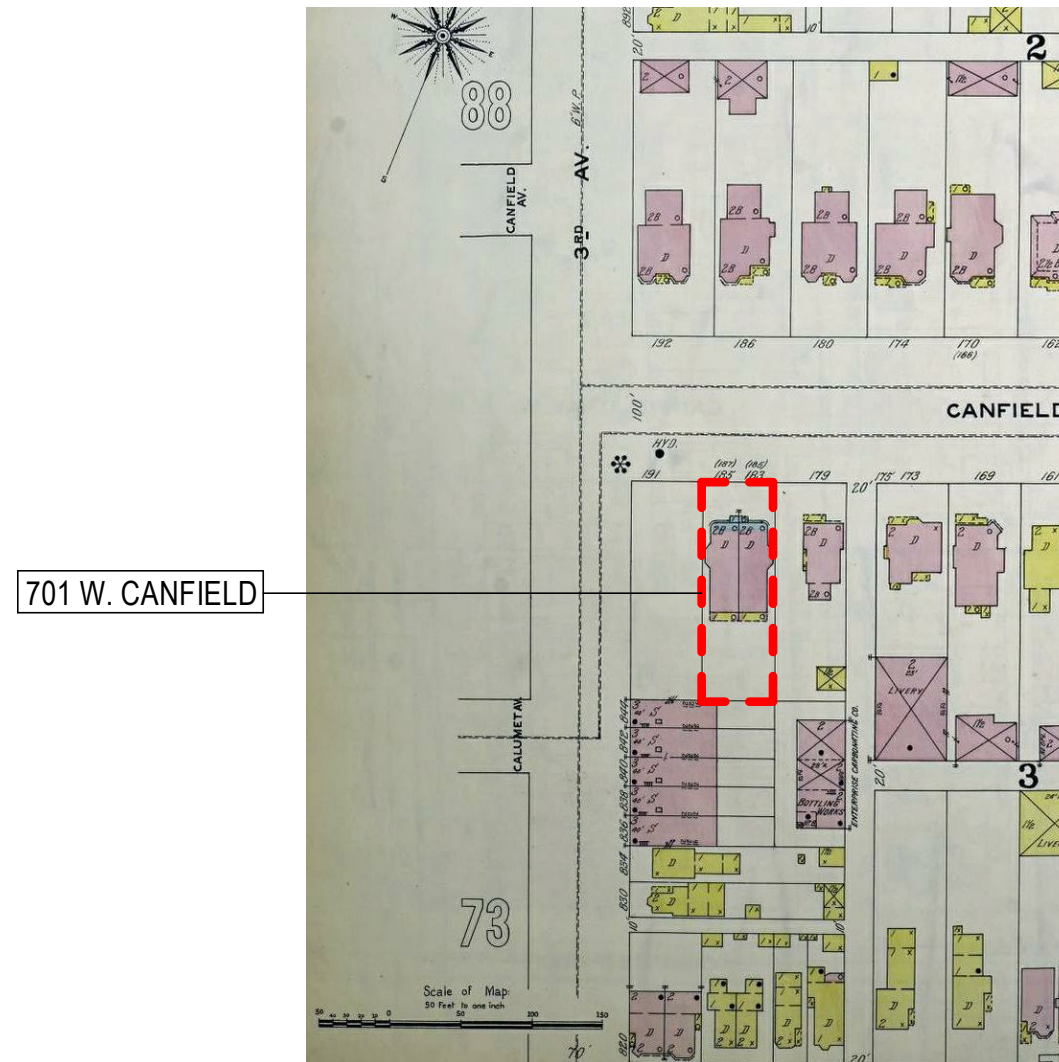

1. 1897 SANBORN MAP VOL. 2, MAP 89

INDEX

SHEET NO.

H.02	HISTORIC PHOTOGRAPHS
H.03	EXISTING CONDITIONS - PHOTOGRAPHS
H.04	EXISTING CONDITIONS - PHOTOGRAPHS
H.05	EXISTING CONDITIONS - PHOTOGRAPHS
H.06	BASEMENT FLOOR PLANS
H.07	FIRST FLOOR PLANS
H.08	SECOND FLOOR PLANS
H.09	THIRD FLOOR PLANS
H.10	PROPOSED NORTH ELEVATION
H.11	PROPOSED EAST ELEVATION
H.12	PROPOSED WEST ELEVATION
H.13	PROPOSED SOUTH ELEVATION
H.14	WINDOW TYPES: BASEMENT
H.15	WINDOW TYPES: 1A, 1C
H.16	WINDOW TYPES: 1B
H.17	WINDOW TYPES: 1D, 1E, 1F
H.18	WINDOW TYPES: 1G, 2A
H.19	WINDOW TYPES 2B
H.20	WINDOW TYPES 2C, 2D, 2E
H.21	WINDOW TYPES 2F, 2G
H.22	WINDOW TYPES 3A, 3B
H.23	WINDOW TYPES 3C, 3D
H.24	WINDOW TYPES 3E
H.25	WINDOW DETAILS: DOUBLE-HUNG WITH TRANSOM
H.26	WINDOW DETAILS: DOUBLE-HUNG
H.27	WINDOW DETAILS: CASEMENT
H.28	WINDOW DETAILS: FRENCH CASEMENT
H.29	WINDOW DETAILS: JAMB & MULLING DETAILS
H.30	WINDOW DETAILS: TYPICAL BASEMENT WINDOW DETAILS
H.31	WINDOW SPECIFICATIONS

SCOPE OF WORK

GENERAL NOTES:

- A.** SEE SHEETS H.14, H.15, H.16, H.17, H.18, H.19, H.20, H.21, H.22, H.23 & H.24 FOR WINDOW TYPES.
- B.** SEE SHEET H.31 FOR PRODUCT SPECIFICATIONS.

NORTH ELEVATION (FRONT):

- A.** REPLACE (8) EXISTING VINYL DOUBLE-HUNG WINDOWS WITH CLAD WOOD DOUBLE-HUNG INSERT WINDOWS.
- B.** REPLACE (8) EXISTING WOOD DOUBLE-HUNG WINDOWS WITH CLAD WOOD DOUBLE-HUNG INSERT WINDOWS.
- C.** REPLACE (2) VINYL CASEMENT WINDOWS WITH (1) FRENCH INSWING CASEMENT CLAD WOOD WINDOW.
- D.** REPLACE (1) WOOD FRENCH INSWING CASEMENT WINDOW WITH A CLAD WOOD FRENCH INSWING CASEMENT WINDOW.
- E.** REPLACE (1) VINYL SLIDING WINDOW WITH (1) CLAD WOOD CASEMENT WINDOW AT BASEMENT.
- F.** REPLACE (2) WOOD CASEMENT WINDOWS WITH CLAD WOOD CASEMENT WINDOWS AT BASEMENT.

EAST ELEVATION:

- A.** REPLACE (7) VINYL SLIDING WINDOWS WITH (7) CLAD WOOD CASEMENT WINDOWS AT BASEMENT. REMOVE METAL GRILLS AT EACH WINDOW.
- B.** REPLACE (12) EXISTING VINYL DOUBLE-HUNG WINDOWS WITH CLAD WOOD DOUBLE-HUNG INSERT WINDOWS.
- C.** REPLACE (2) EXISTING VINYL CASEMENT WINDOWS WITH (2) CLAD WOOD DOUBLE-HUNG INSERT WINDOWS.
- D.** REPLACE (1) EXISTING VINYL CASEMENT WINDOW WITH (1) CLAD WOOD CASEMENT INSERT WINDOW.

SOUTH ELEVATION (REAR):

NO WORK PROPOSED AT THIS AREA

WEST ELEVATION:

- A.** REPLACE (6) WOOD CASEMENT WINDOWS WITH CLAD WOOD CASEMENT WINDOWS AT BASEMENT.
- B.** REPLACE (12) EXISTING WOOD DOUBLE-HUNG WINDOWS WITH CLAD WOOD DOUBLE-HUNG INSERT WINDOWS.
- C.** REPLACE (2) EXISTING WOOD CASEMENT WINDOWS WITH (2) CLAD WOOD CASEMENT WINDOWS.
- D.** REPLACE (1) EXISTING WOOD CASEMENT WINDOW WITH (1) CLAD WOOD CASEMENT WINDOW.



1. PHOTO FROM STREET - CA. 1970



2. PHOTO FROM STREET - DATE UNKNOWN



1. PHOTO FROM STREET - EXISTING CONDITIONS



2. PHOTO FROM REAR - EXISTING CONDITIONS



5. WEST ELEV. (TOWARD SOUTH)



6. WEST ELEV. (TOWARD SOUTH)



7. WEST ELEV. (TOWARD NORTH)



8. WEST ELEV. (TOWARD NORTH)



1. EAST ELEV. (TOWARD NORTH)

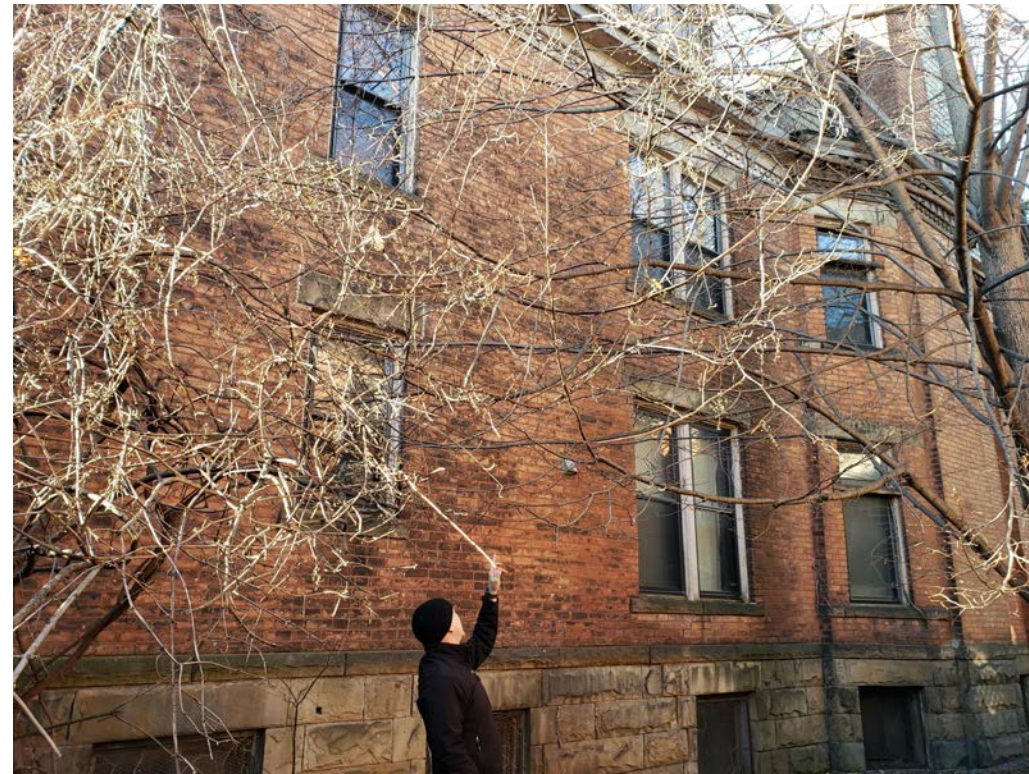

2. EAST ELEVATION (TOWARD NORTH)



3. EAST ELEV. (TOWARD SOUTH)



4. EAST ELEV. (TOWARD SOUTH)



4. EXISTING WINDOW TYPE 1F (WEST)



5. EXISTING WINDOW TYPES 3C & 3D (WEST)



6. EXISTING WINDOW TYPES 3C & 3D (EAST)



1. EXISTING WINDOW TYPES 1D & 1E (WEST)



2. EXISTING WINDOW TYPE 2A (WEST)



3. EXISTING WINDOW TYPES 2A & 2B (EAST)

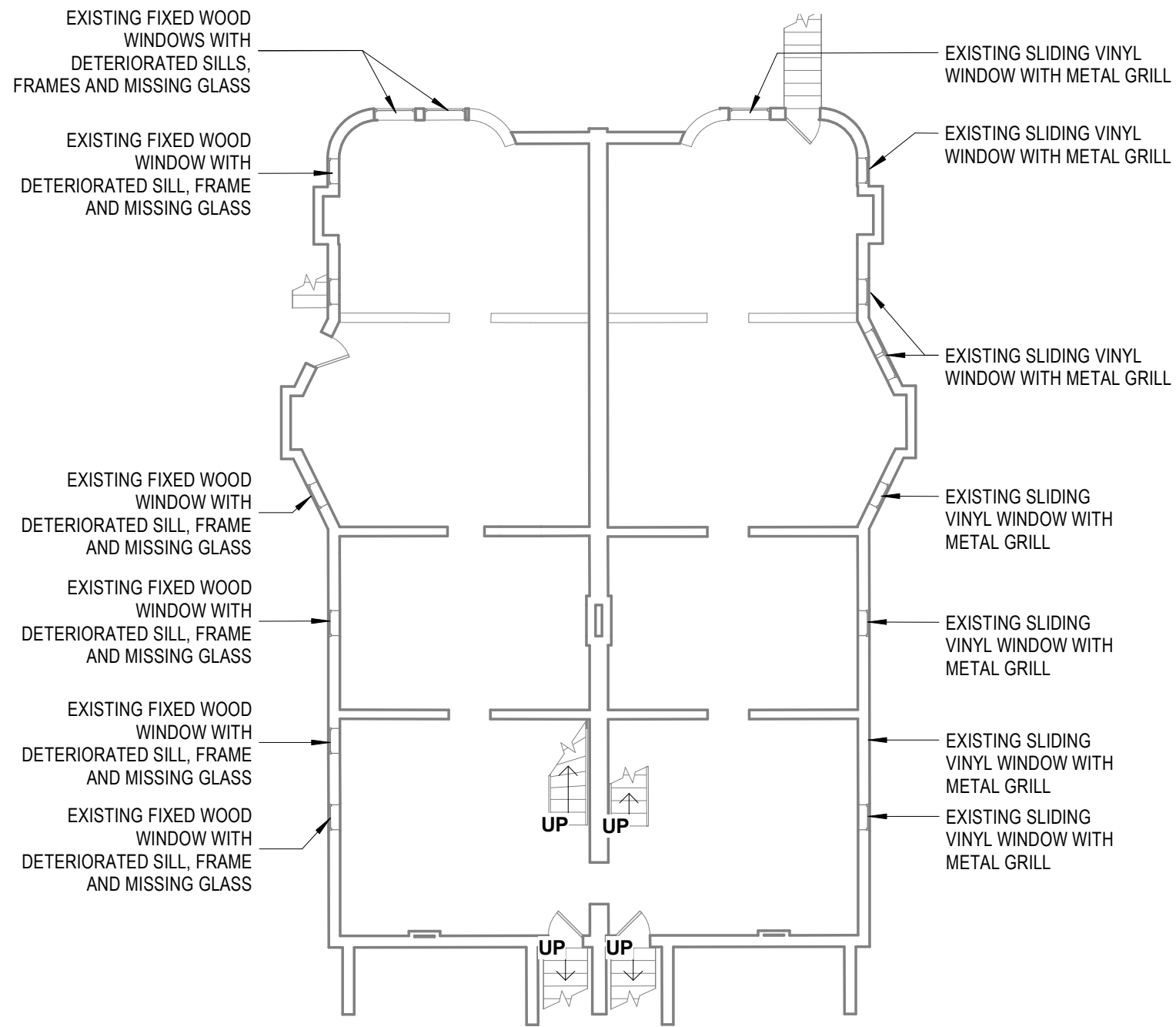

1 EXISTING BASEMENT FLOORPLAN

H.06 3/32" = 1'-0"

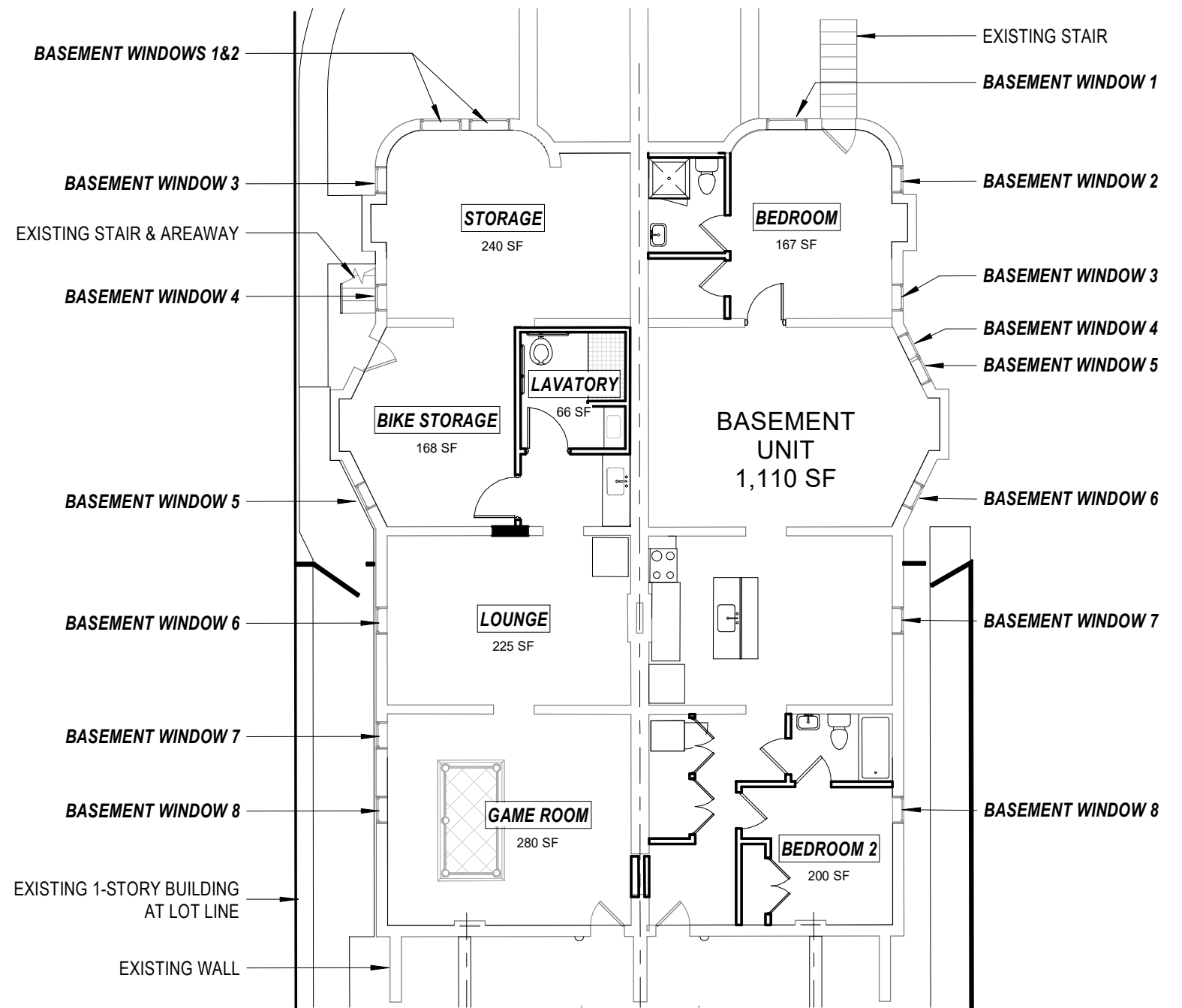

2 BASEMENT CONSTRUCTION PLAN

H.06 3/32" = 1'-0"

GENERAL NOTES:

- 1. REMOVE EXISTING METAL SECURITY GRILLS WHERE PRESENT.
- 2. INSTALL CASEMENT AT ALL BASEMENT WINDOW OPENINGS - SEE 1/H.14 FOR WINDOW TYPE.

12.09.2020

CANFIELD APARTMENTS

H.06

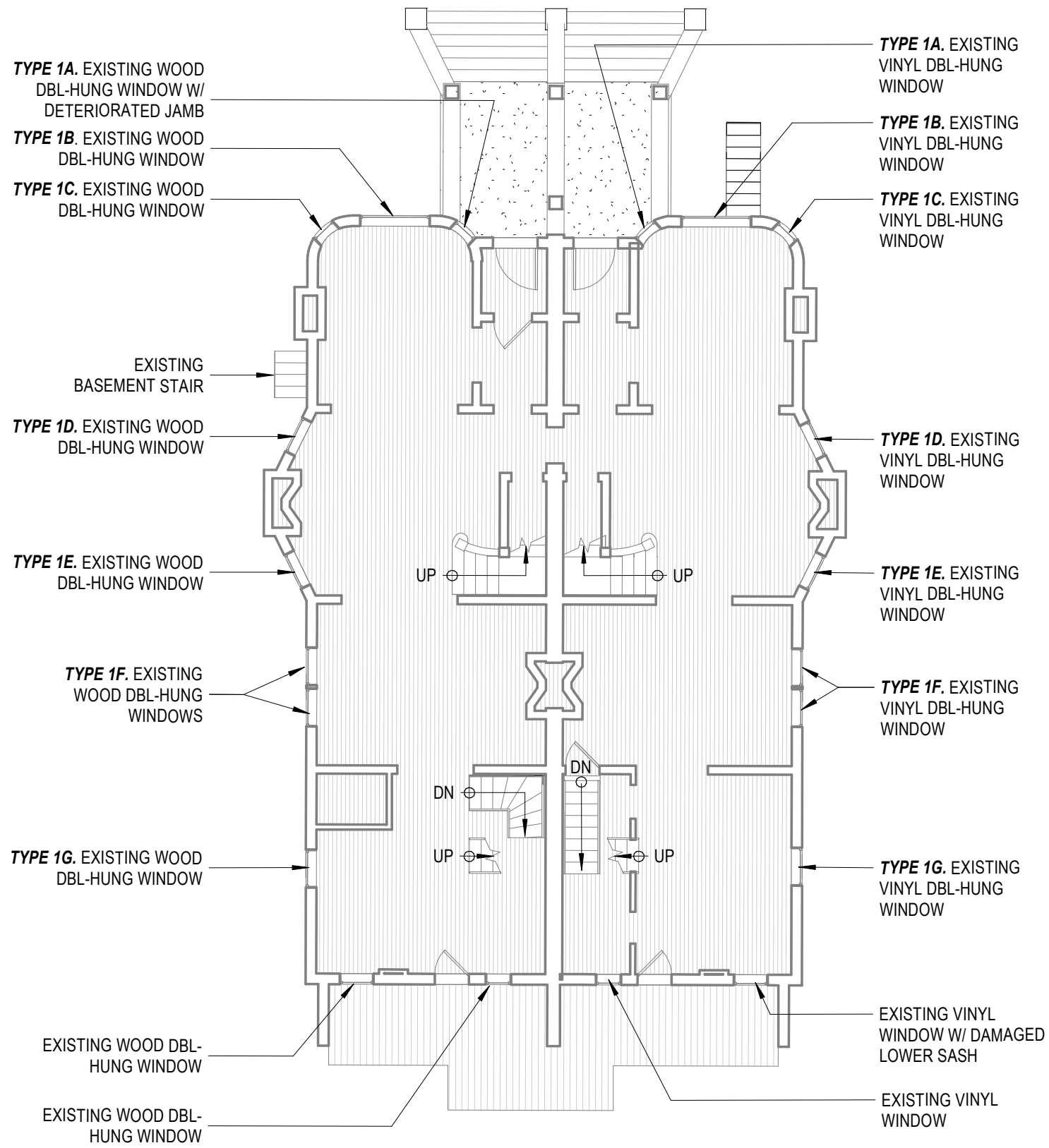

1 EXISTING FIRST FLOORPLAN

H.07 3/32" = 1'-0"

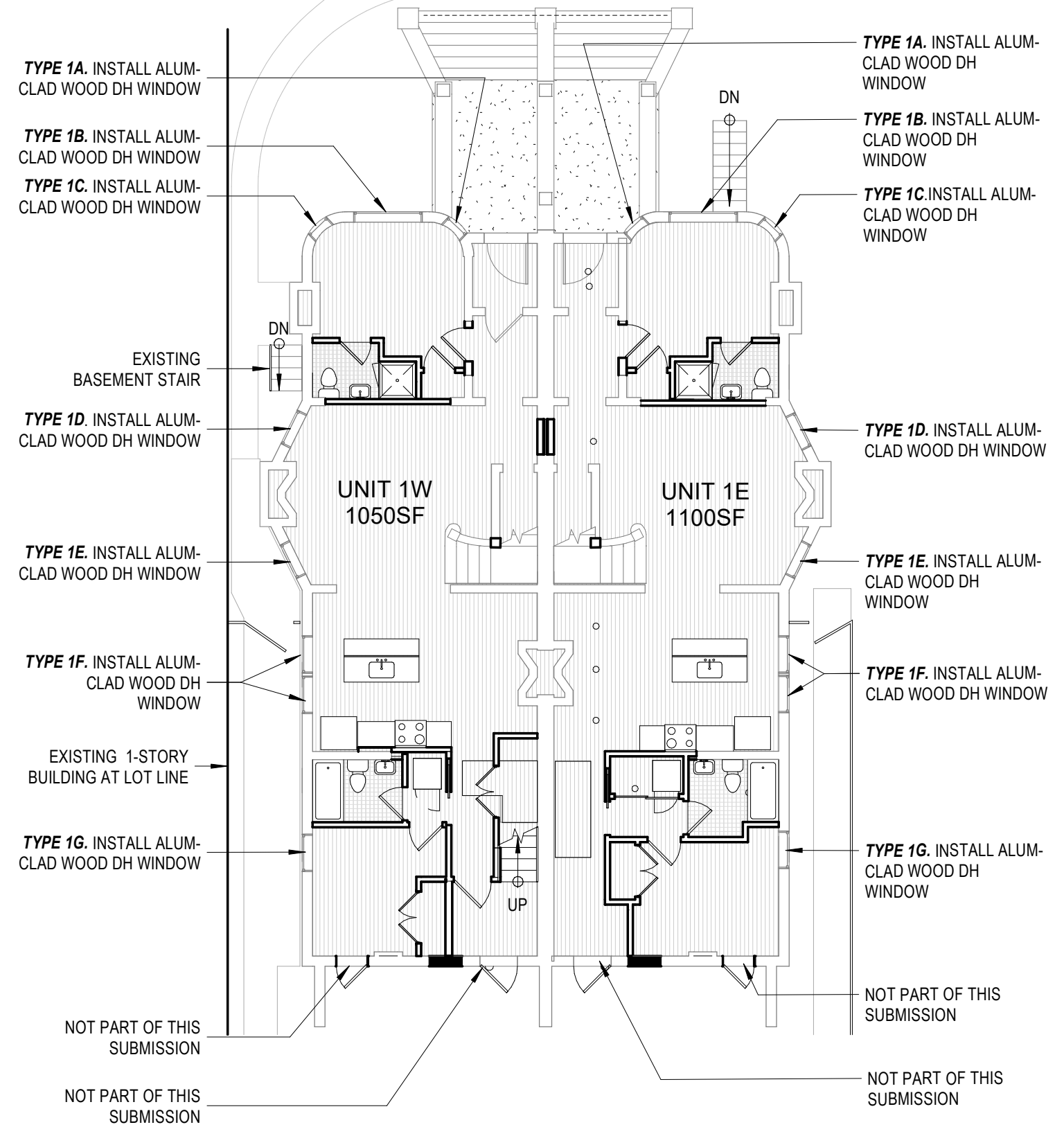

2 PROPOSED FIRST FLOORPLAN

H.07 3/32" = 1'-0"

SEE SHEET H.15 & H.16 FOR WINDOW TYPES

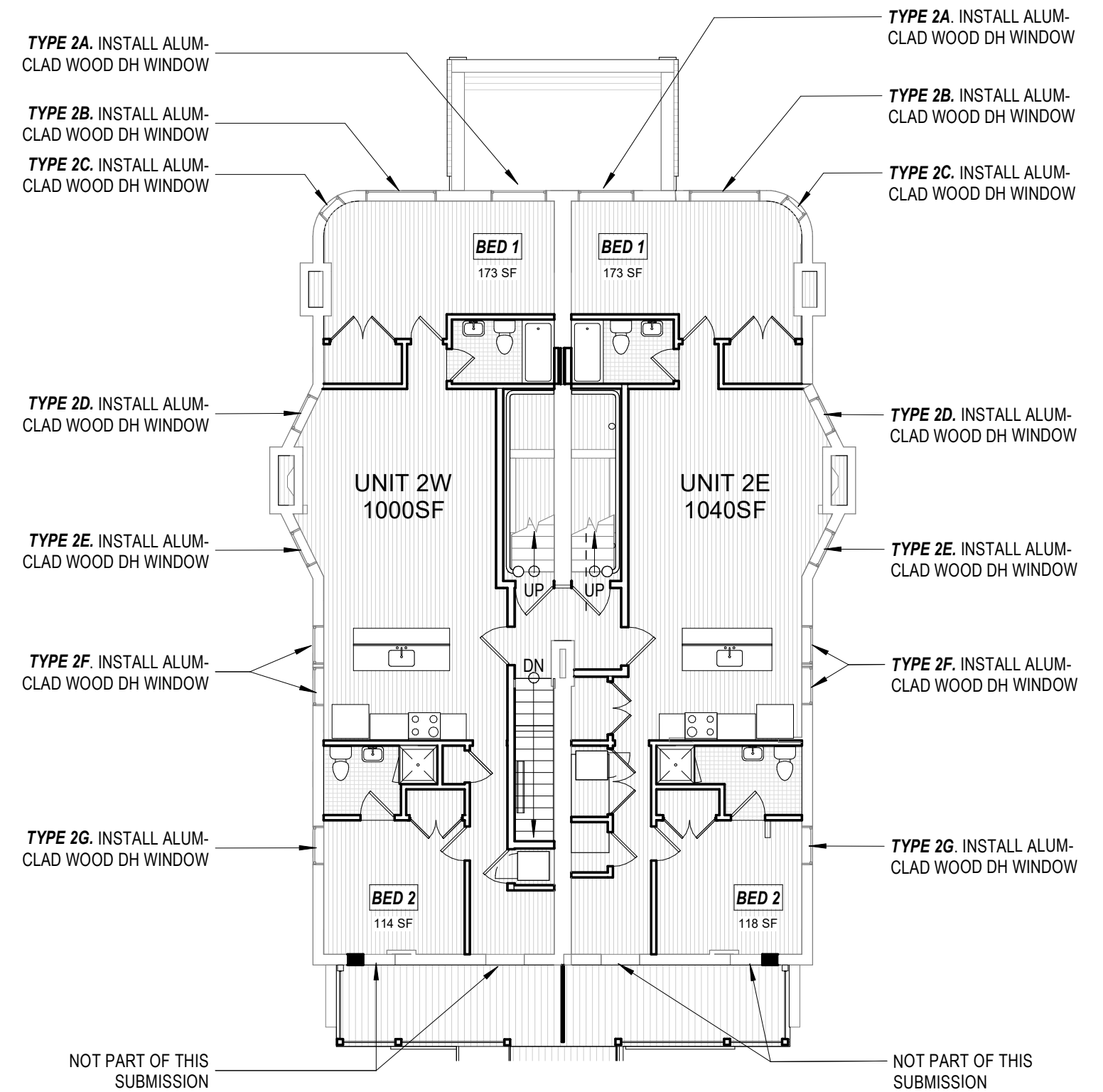
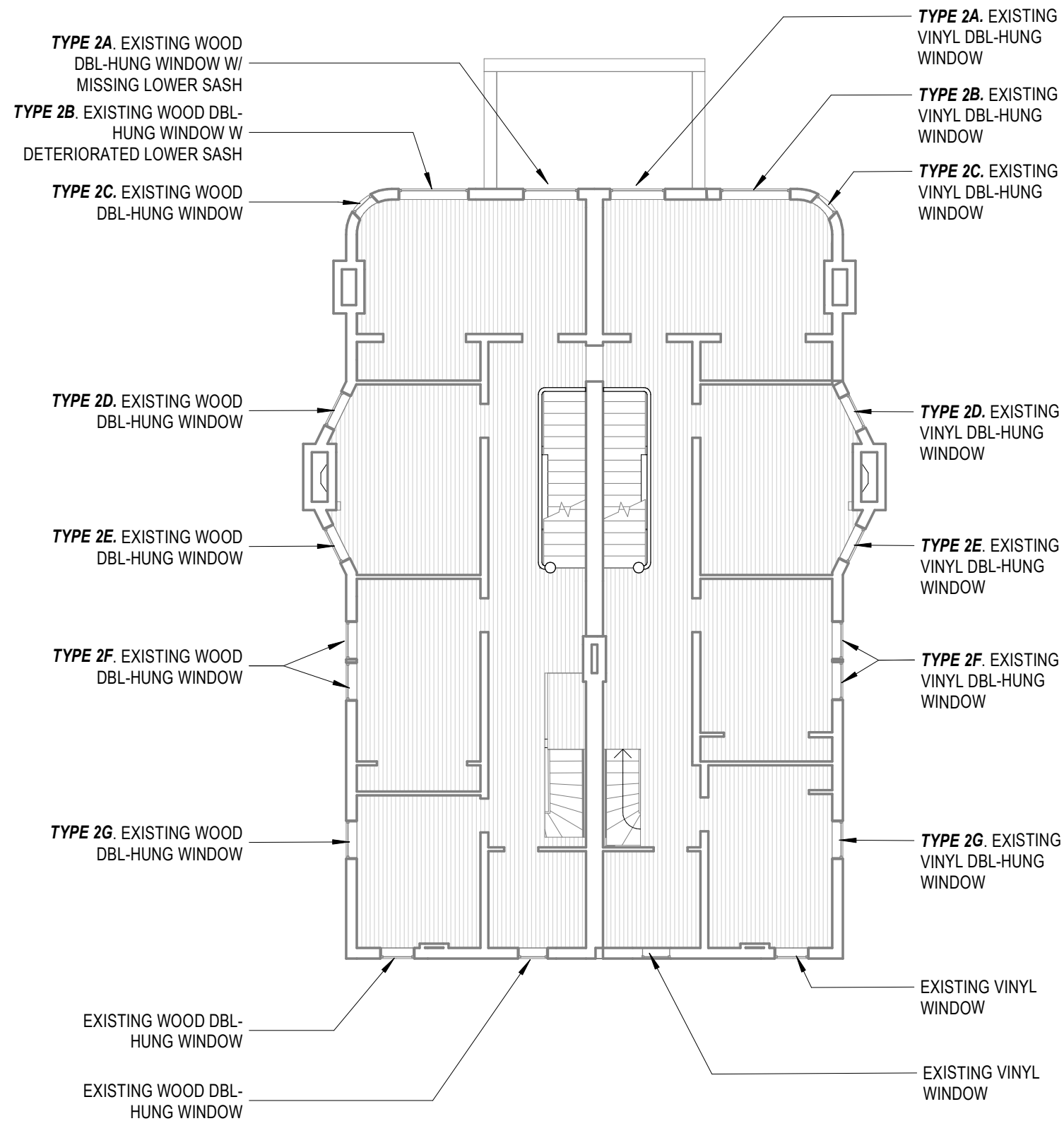

1 EXISTING SECOND FLOORPLAN

H.08 3/32" = 1'-0"

SEE SHEET H.16 & H.17 FOR WINDOW TYPES

2 PROPOSED SECOND FLOORPLAN

H.08 3/32" = 1'-0"

SEE SHEET H.16 & H.17 FOR WINDOW TYPES

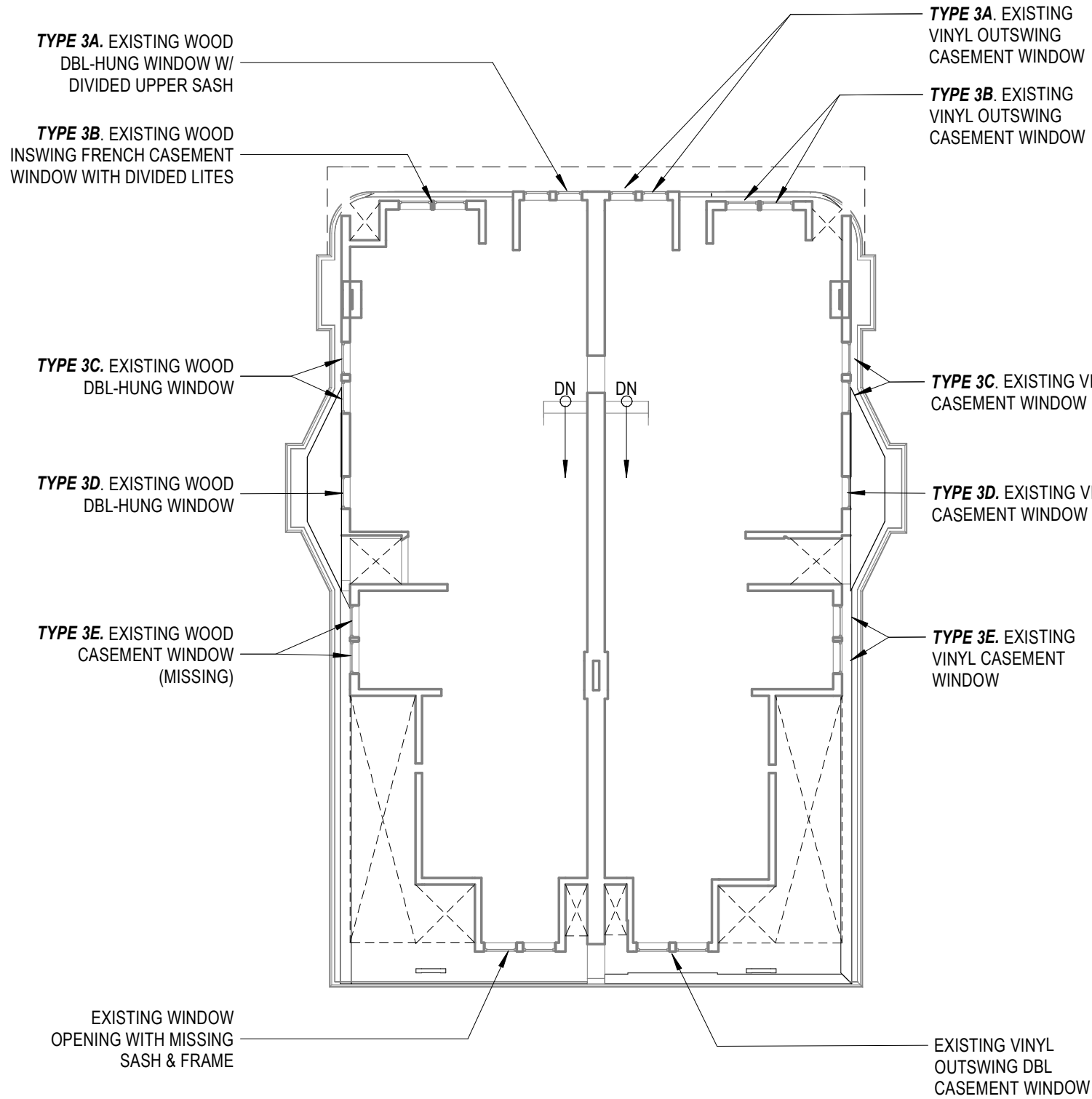

TYPE 3A. EXISTING WOOD DBL-HUNG WINDOW W/ DIVIDED UPPER SASH

TYPE 3B. EXISTING WOOD INSWING FRENCH CASEMENT WINDOW WITH DIVIDED LITES

TYPE 3C. EXISTING WOOD DBL-HUNG WINDOW

TYPE 3D. EXISTING WOOD DBL-HUNG WINDOW

TYPE 3E. EXISTING WOOD CASEMENT WINDOW (MISSING)

EXISTING WINDOW OPENING WITH MISSING SASH & FRAME

TYPE 3A. EXISTING VINYL OUTSWING CASEMENT WINDOW

TYPE 3B. EXISTING VINYL OUTSWING CASEMENT WINDOW

TYPE 3C. EXISTING VINYL CASEMENT WINDOW

TYPE 3D. EXISTING VINYL CASEMENT WINDOW

TYPE 3E. EXISTING VINYL CASEMENT WINDOW

EXISTING VINYL OUTSWING DBL CASEMENT WINDOW

TYPE 3A. INSTALL ALUM-CLAD WOOD DH WINDOW WITH DIVIDED LITES
TYPE 3B. INSTALL ALUM-CLAD WOOD INSWING FRENCH CASEMENT WINDOW

TYPE 3C. INSTALL ALUM-CLAD WOOD DH WINDOW

TYPE 3D. INSTALL ALUM-CLAD WOOD DH WINDOW

TYPE 3E. INSTALL ALUM-CLAD WOOD CASEMENT WINDOW

NOT PART OF THIS SUBMISSION

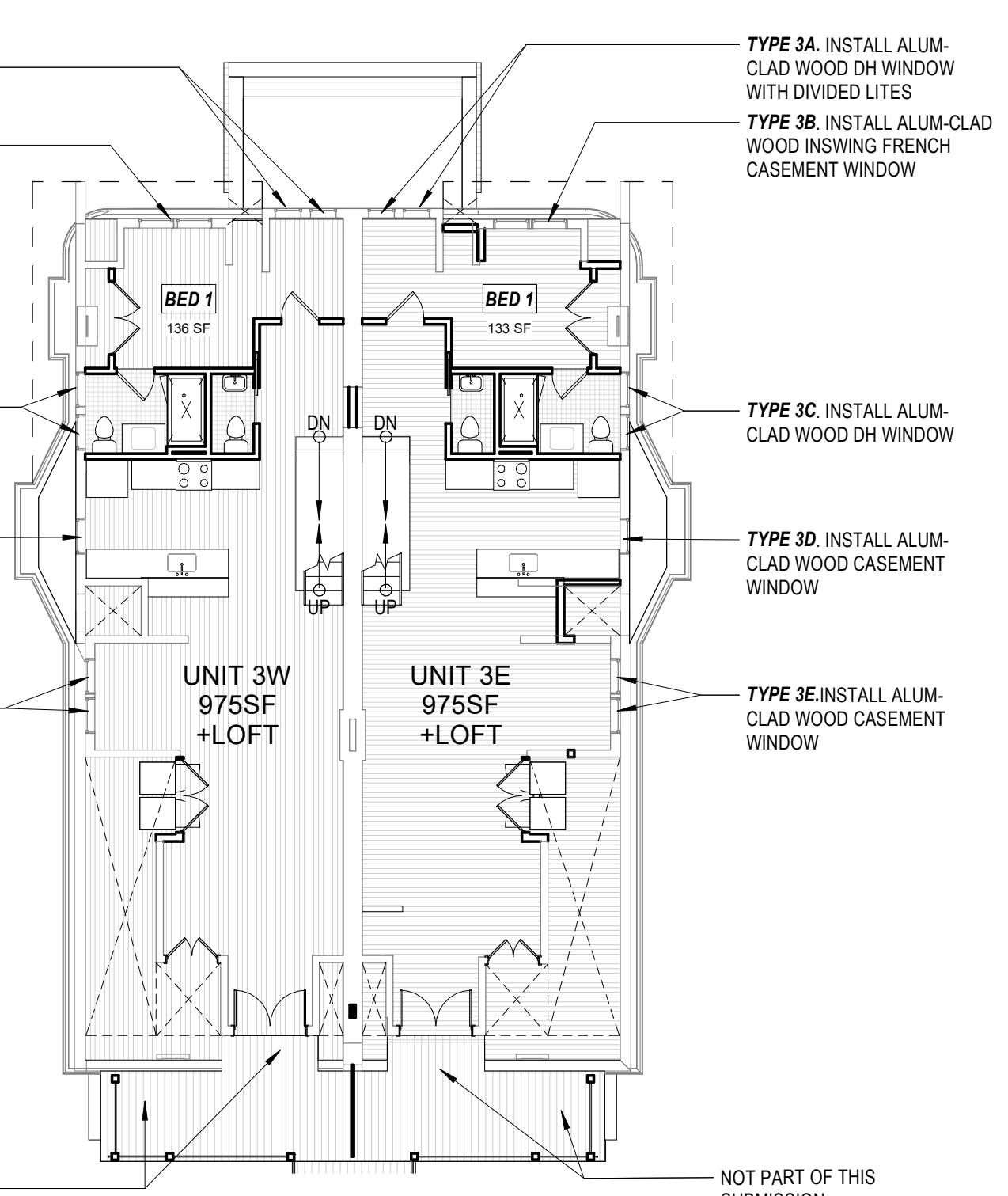

TYPE 3A. INSTALL ALUM-CLAD WOOD DH WINDOW WITH DIVIDED LITES

TYPE 3B. INSTALL ALUM-CLAD WOOD INSWING FRENCH CASEMENT WINDOW

TYPE 3C. INSTALL ALUM-CLAD WOOD DH WINDOW

TYPE 3D. INSTALL ALUM-CLAD WOOD CASEMENT WINDOW

TYPE 3E. INSTALL ALUM-CLAD WOOD CASEMENT WINDOW

NOT PART OF THIS SUBMISSION

1 EXISTING THIRD FLOORPLAN

H.09 3/32" = 1'-0"

SEE SHEET H.18 FOR WINDOW TYPES

2 PROPOSED THIRD FLOORPLAN

H.09 3/32" = 1'-0"

SEE SHEET H.18 FOR WINDOW TYPES



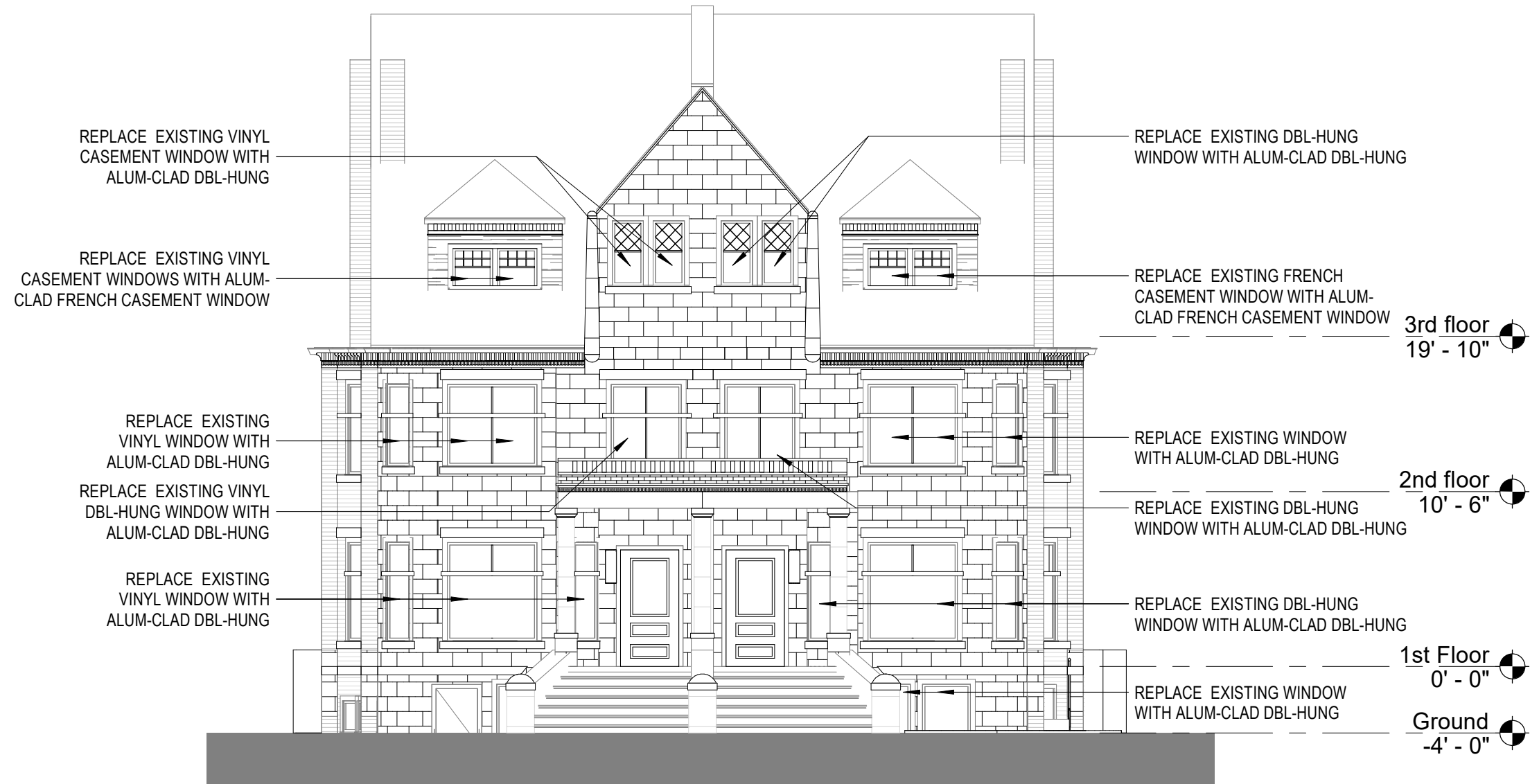

1 PROPOSED NORTH ELEVATION (STREET)

H.10 | 1/8" = 1'-0"



1 PROPOSED EAST ELEVATION

H.11 | 1/8" = 1'-0"



1 PROPOSED WEST ELEVATION

H.12 | 1/8" = 1'-0"



1 SOUTH ELEVATION (FOR REFERENCE ONLY - NO PROPOSED WORK IN THIS SUBMISSION)

H.13 3/16" = 1'-0"



1. TYPICAL BASEMENT WINDOW EXTERIOR (EAST)

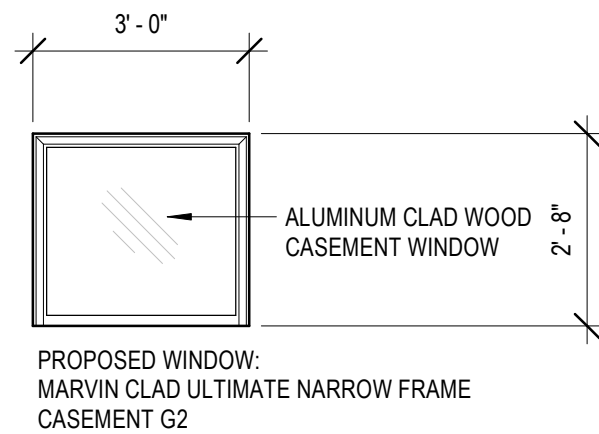
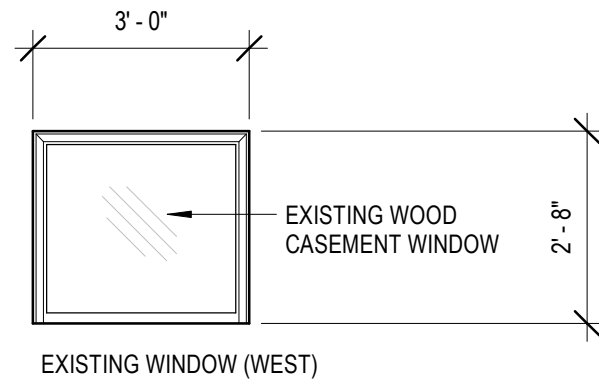
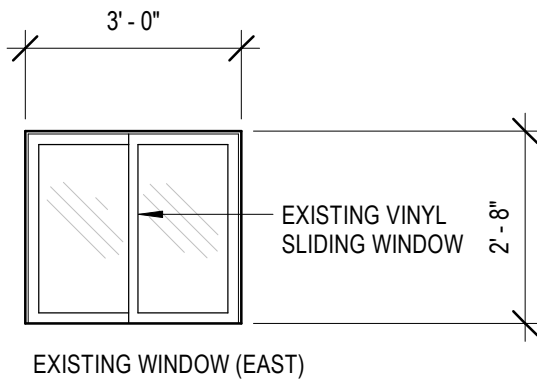

EXISTING BASEMENT
WOOD WINDOWS 1 & 2 (WEST)



EXISTING BASEMENT
VINYL WINDOW 1 (EAST)



EXISTING BASEMENT
VINYL WINDOW 2 (EAST)



EXISTING BASEMENT
VINYL WINDOW 3 (EAST)



EXISTING BASEMENT
WOOD WINDOW 3 (WEST)



EXISTING BASEMENT
VINYL WINDOWS 4 & 5 (EAST)



EXISTING BASEMENT
WOOD WINDOW 4 (WEST)



EXISTING BASEMENT
VINYL WINDOW 7 (EAST)



EXISTING BASEMENT
WOOD WINDOW 5 (WEST)



EXISTING BASEMENT
VINYL WINDOW 8 (EAST)



EXISTING BASEMENT
WOOD WINDOW 4 (WEST)

1 WINDOW TYPE - TYPICAL AT BASEMENT

H.14 | 3/8" = 1'-0"

SEE DETAILS ON SHEET H.27

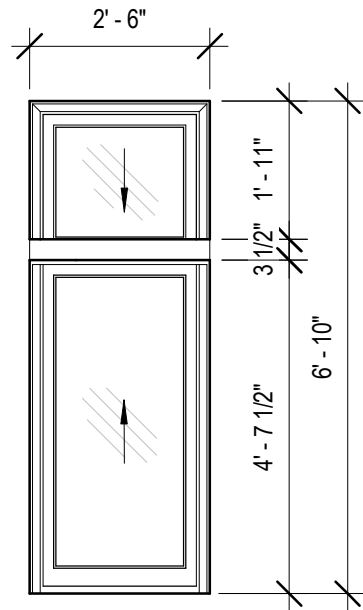

EXISTING WINDOWS
 EAST - VINYL DOUBLE-HUNG
 WEST - WOOD DOUBLE-HUNG



1A EAST - EXISTING EXTERIOR
 VINYL DOUBLE-HUNG



1A EAST - EXISTING INTERIOR
 VINYL DOUBLE-HUNG



1A WEST - EXTERIOR
 WOOD DOUBLE-HUNG



1A WEST - EXISTING INTERIOR
 WOOD DOUBLE-HUNG

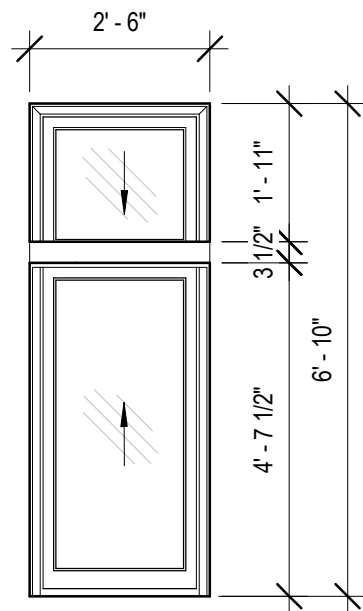

PROPOSED WINDOW:
 MARVIN CLAD ULTIMATE
 DBL-HUNG G2



1C EAST - EXISTING EXTERIOR
 WOOD DOUBLE-HUNG



1C EAST - EXISTING INTERIOR
 WOOD DOUBLE-HUNG



1C WEST - EXTERIOR
 WOOD DOUBLE-HUNG



1C WEST - EXISTING INTERIOR
 WOOD DOUBLE-HUNG

1 WINDOW TYPES 1A & 1C

H.15 | 3/8" = 1'-0"

SEE DETAILS ON SHEET H.25

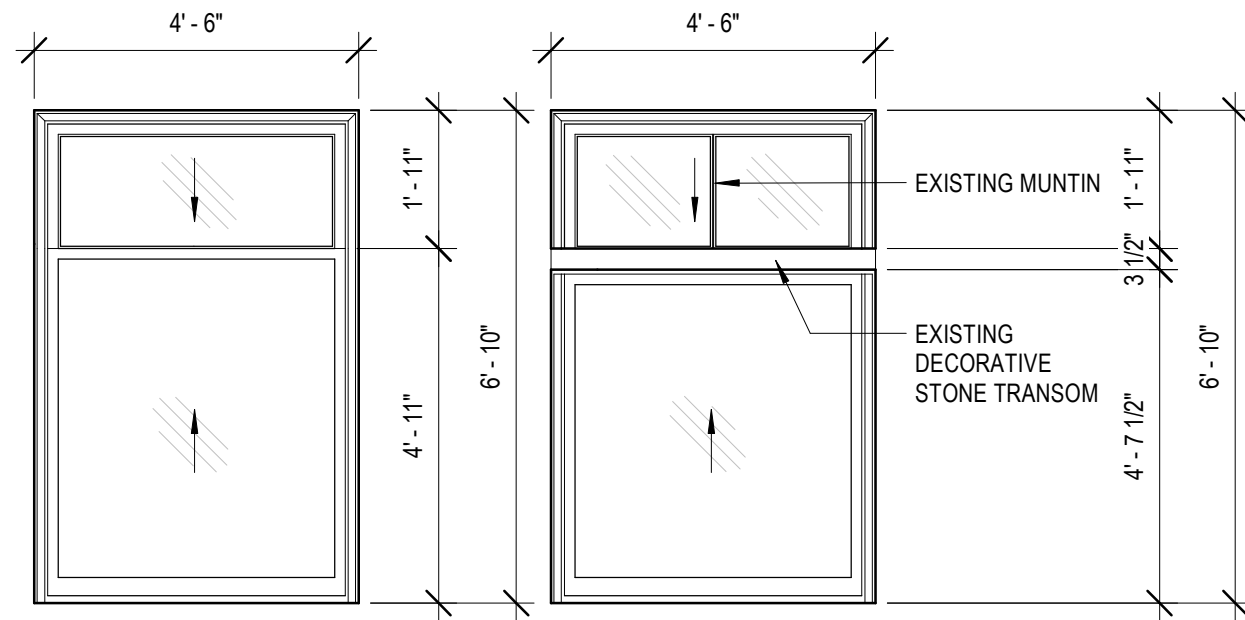

EXISTING WINDOW 1B - EAST
VINYL DOUBLE-HUNG

EXISTING WINDOW 1B - WEST
WOOD DOUBLE-HUNG



EXISTING WINDOW 1B - EAST
VINYL DOUBLE-HUNG

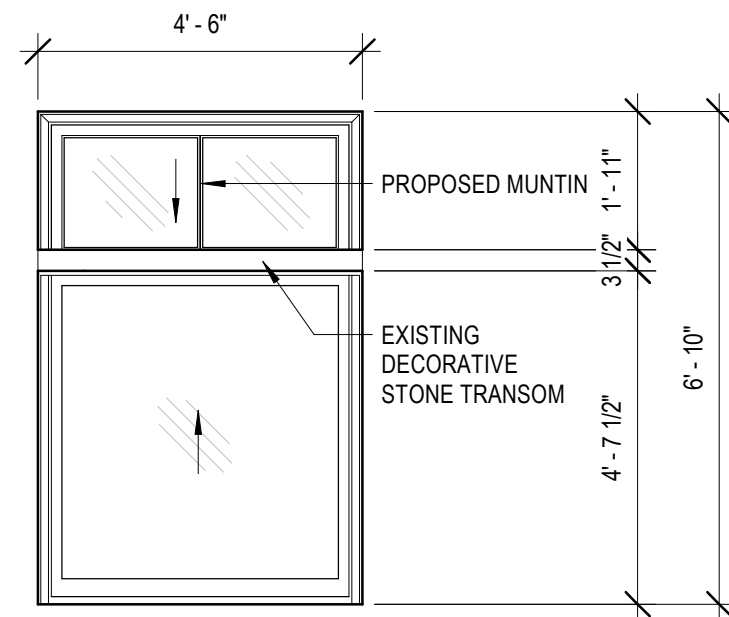

PROPOSED WINDOW:
MARVIN CLAD ULTIMATE
DBL-HUNG G2



EXISTING WINDOW 1B - WEST
WOOD DOUBLE-HUNG

1 WINDOW TYPE 1B

H.16 | 3/8" = 1'-0"

SEE DETAILS ON SHEET H.25

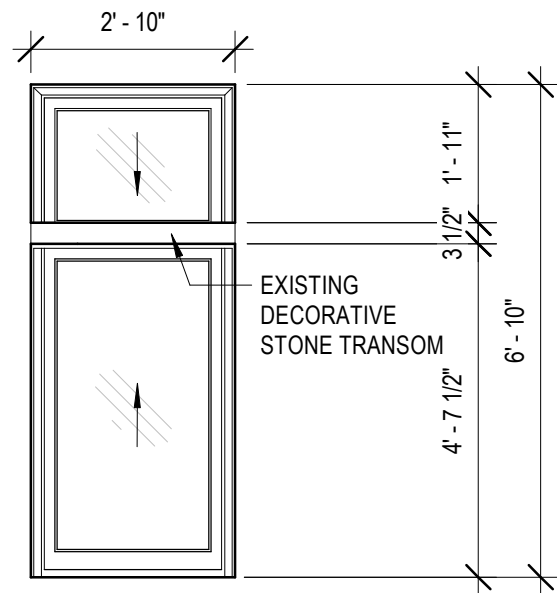

WINDOW 1D - EAST
VINYL DOUBLE-HUNG



EXISTING WINDOW 1D - WEST
WOOD DOUBLE-HUNG



EXISTING WINDOW 1F - EAST
VINYL DOUBLE-HUNG



EXISTING WINDOW 1F - WEST
WOOD DOUBLE-HUNG

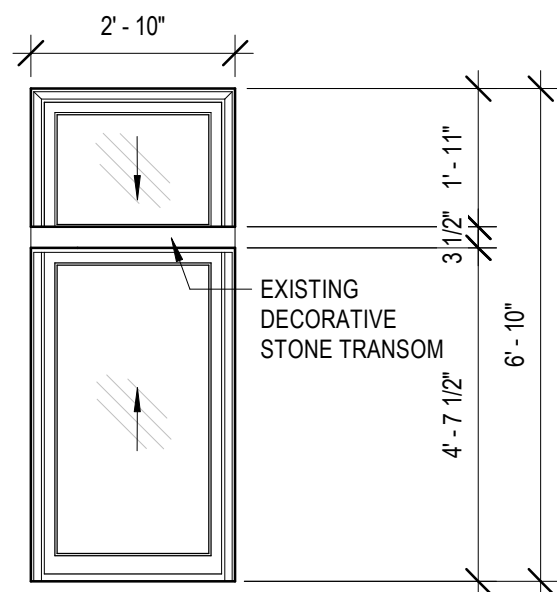

WINDOW 1E - EAST
VINYL DOUBLE-HUNG



WINDOW 1E - WEST
WOOD DOUBLE-HUNG



WINDOW 1E - WEST INTERIOR
WOOD DOUBLE-HUNG

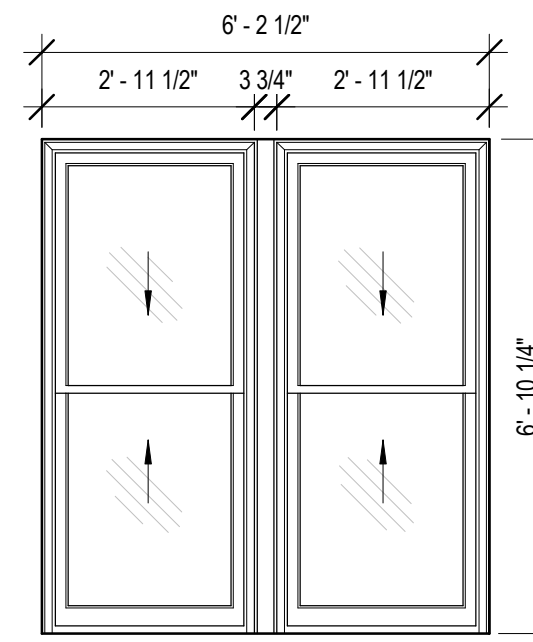

EXISTING WINDOW 1F:
EAST: VINYL DOUBLE-HUNG
WEST: WOOD DOUBLE-HUNG

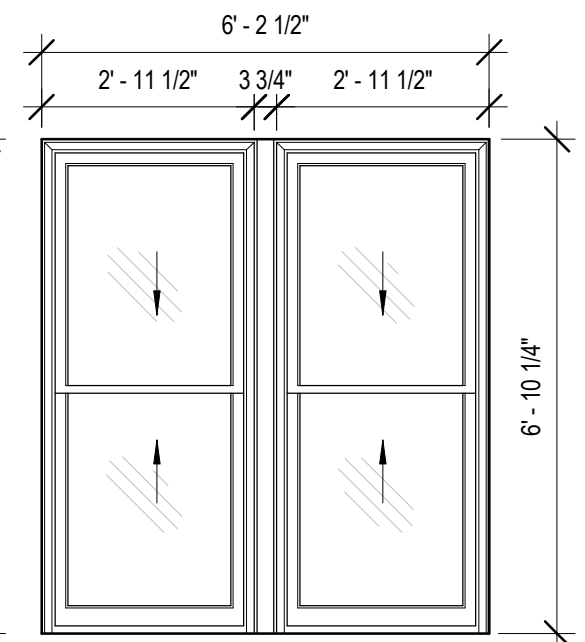

PROPOSED WINDOW:
MARVIN CLAD ULTIMATE
DBL-HUNG G2

1 WINDOW TYPES 1D & 1E

H.17 | 3/8" = 1'-0"

SEE DETAILS ON SHEET H.25

2 WINDOW TYPE 1F

H.17 | 3/8" = 1'-0"

SEE DETAILS ON SHEET H.26 & H.29

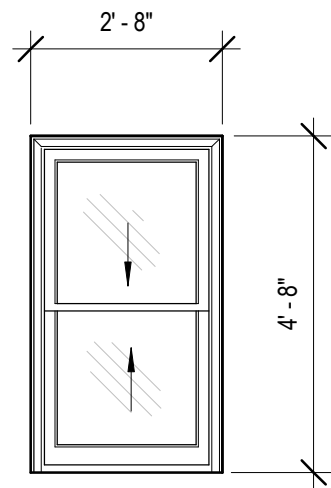

EXISTING WINDOW 1G
EAST: VINYL DOUBLE-HUNG
WEST: WOOD DOUBLE-HUNG

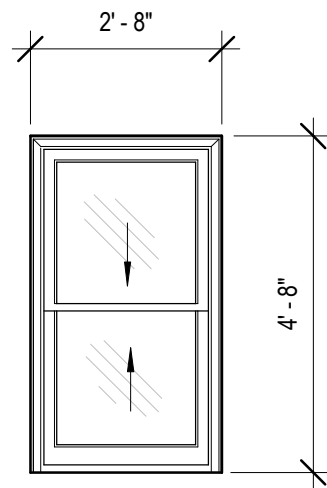

PROPOSED WINDOW:
MARVIN CLAD ULTIMATE
DBL-HUNG G2



WINDOW 1G - EAST
VINYL DOUBLE-HUNG



WINDOW 1G - EAST (INTERIOR)
VINYL DOUBLE-HUNG



EXISTING WINDOW 1G - WEST
WOOD DOUBLE-HUNG

2 WINDOW TYPE 1G

H.18 | 3/8" = 1'-0"

SEE DETAILS ON SHEET H.26

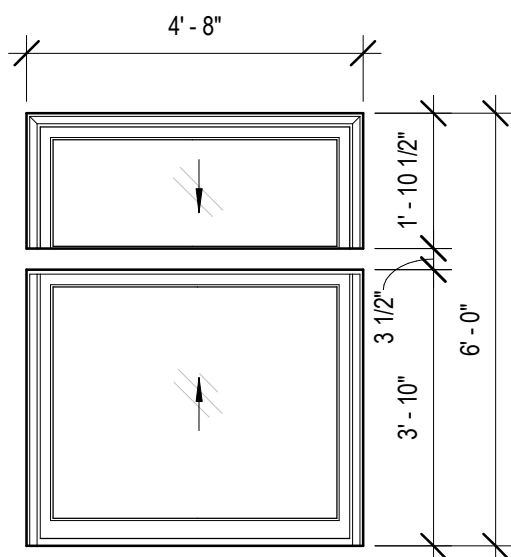

EXISTING WINDOW 2A EAST:
VINYL DOUBLE-HUNG

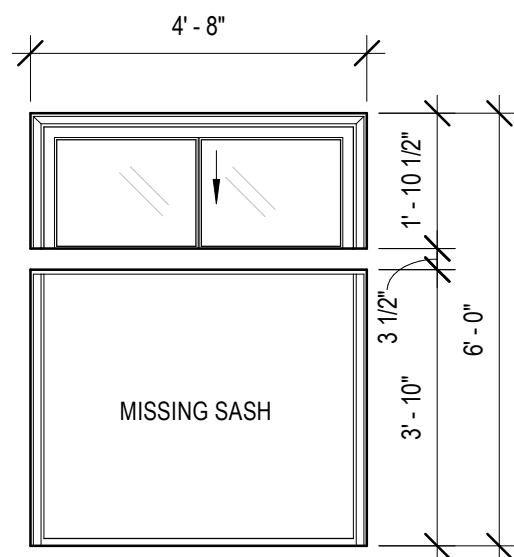

EXISTING WINDOW 2A WEST:
WOOD DOUBLE-HUNG

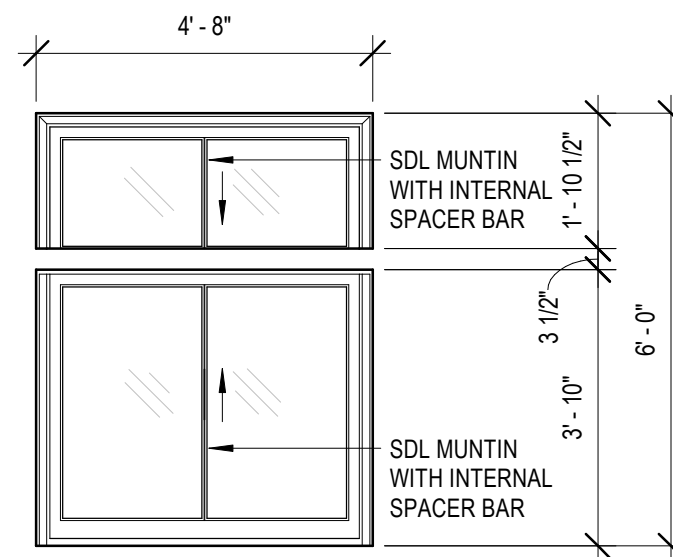

PROPOSED WINDOW:
MARVIN CLAD ULTIMATE
DBL-HUNG G2



EXISTING WINDOW 2A EAST:
VINYL DOUBLE-HUNG

EXISTING WINDOW 2A WEST:
WOOD DOUBLE-HUNG

3 WINDOW TYPE 2A

H.18 | 3/8" = 1'-0"

SEE DETAILS ON SHEET H.25

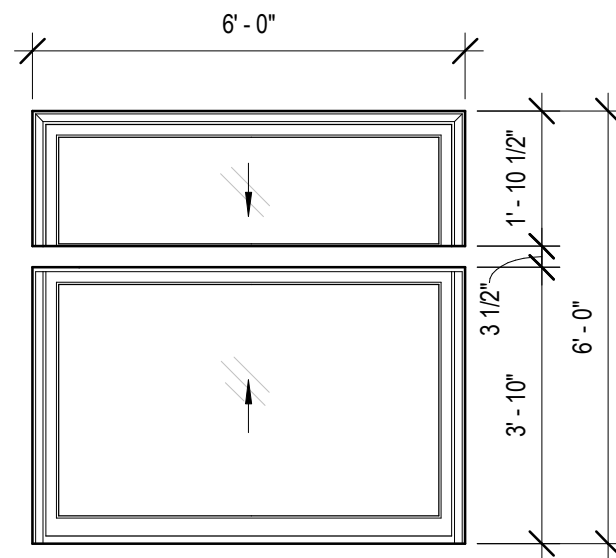

EXISTING WINDOW 2B EAST:
VINYL DOUBLE-HUNG

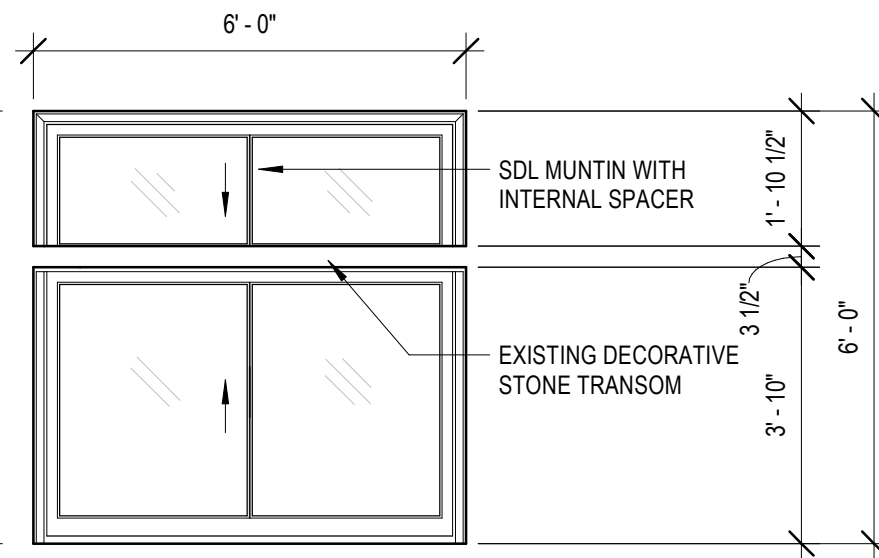

EXISTING WINDOW 2B WEST:
WOOD DOUBLE-HUNG

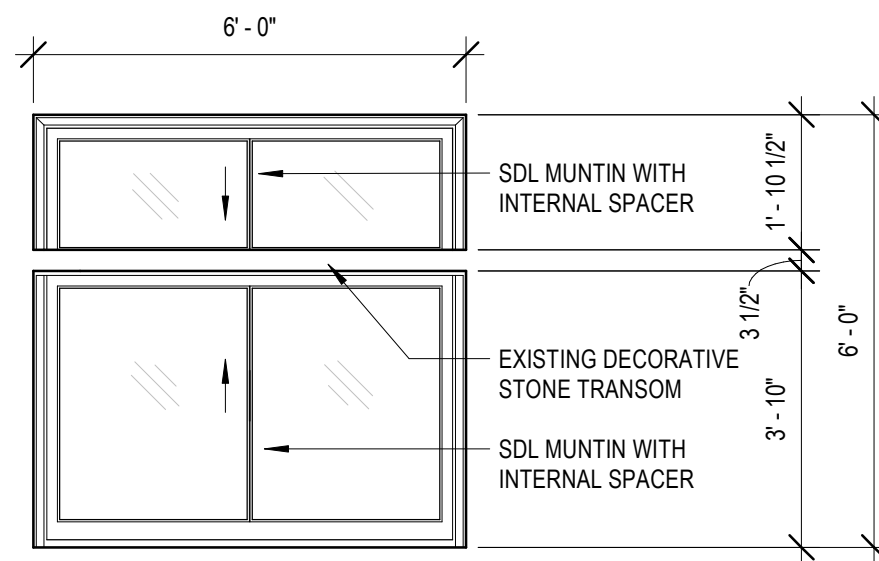

PROPOSED WINDOW:
MARVIN CLAD ULTIMATE DBL-HUNG G2
WITH UPPER & LOWER MUNTIN



WINDOW 2B - EAST
VINYL DOUBLE-HUNG



WINDOW 2B - EAST (INTERIOR)
VINYL DOUBLE-HUNG

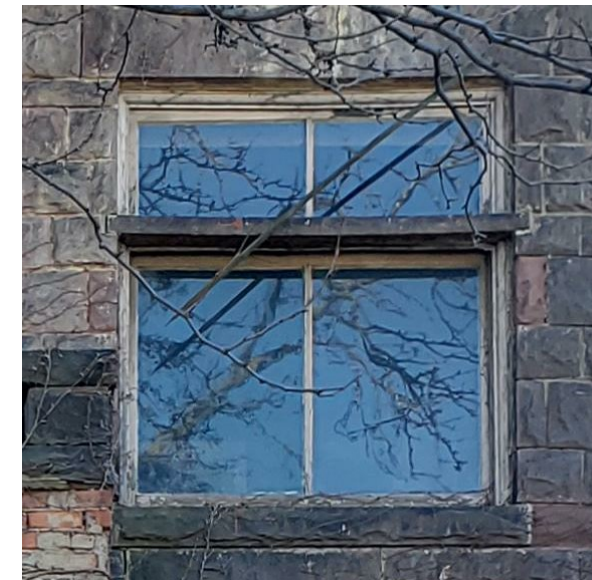

WINDOW 2B - WEST
WOOD DOUBLE-HUNG

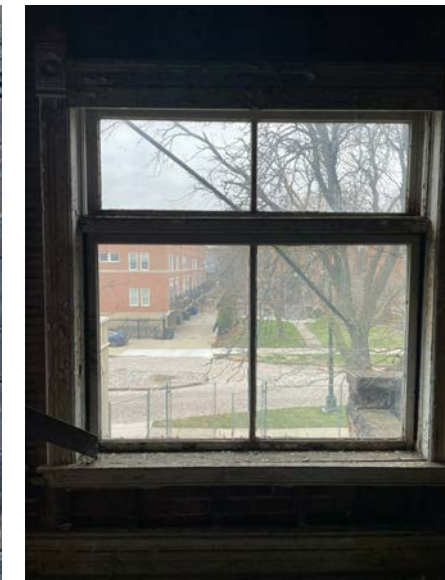

WINDOW 2B - WEST (INTERIOR)
WOOD DOUBLE-HUNG

1 WINDOW TYPE 2B

H.19 | 3/8" = 1'-0"

SEE DETAILS ON SHEET H.25

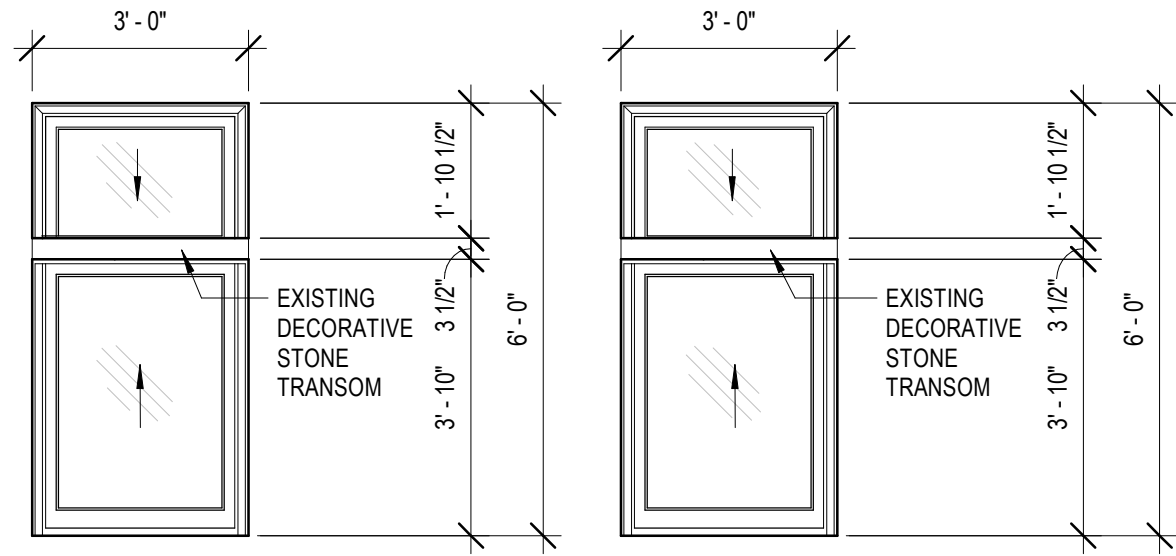

EXISTING WINDOW 2D & 2E:
 EAST: VINYL DOUBLE-HUNG
 WEST: WOOD DOUBLE-HUNG

PROPOSED WINDOW:
 MARVIN CLAD ULTIMATE DBL-HUNG G2



WINDOW 2D - EAST
 VINYL DOUBLE-HUNG



WINDOW 2E - EAST
 VINYL DOUBLE-HUNG



WINDOW 2D - WEST (INTERIOR)
 WOOD DOUBLE-HUNG



WINDOW 2E - WEST (INTERIOR)
 WOOD DOUBLE-HUNG

2 WINDOW TYPES 2D & 2E

H.20 | 3/8" = 1'-0"

SEE DETAILS ON SHEET H.25

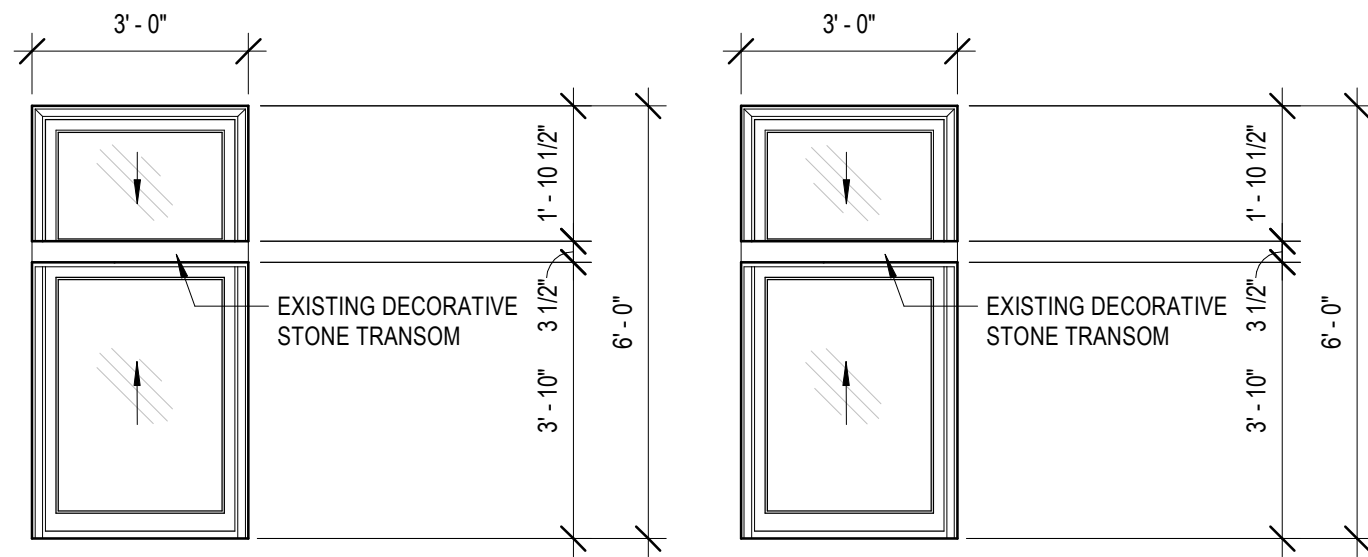

EXISTING WINDOW 2C:
 EAST: VINYL DOUBLE-HUNG
 WEST: WOOD DOUBLE-HUNG

PROPOSED WINDOW:
 MARVIN CLAD ULTIMATE DBL-HUNG G2



WINDOW 2C - EAST (INTERIOR)
 VINYL DOUBLE-HUNG



WINDOW 2C - WEST
 WOOD DOUBLE-HUNG



WINDOW 2C - WEST (INTERIOR)
 WOOD DOUBLE-HUNG

1 WINDOW TYPES 2C

H.20 | 3/8" = 1'-0"

SEE DETAILS ON SHEET H.25

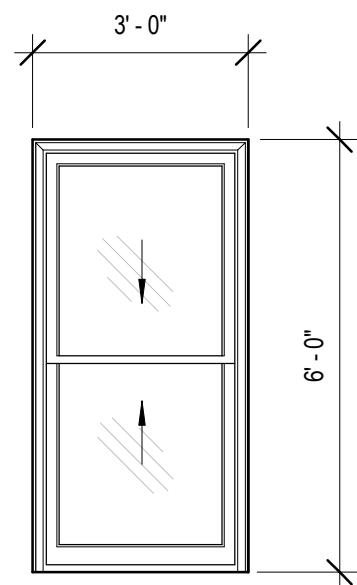

PROPOSED WINDOW:
MARVIN CLAD ULTIMATE DBL-HUNG G2

WINDOW 2G - EAST
VINYL DOUBLE-HUNG

WINDOW 2G - EAST (INTERIOR)
VINYL DOUBLE-HUNG

WINDOW 2G - WEST (INTERIOR)
WOOD DOUBLE-HUNG

2G

SEE DETAILS ON SHEETS H.26

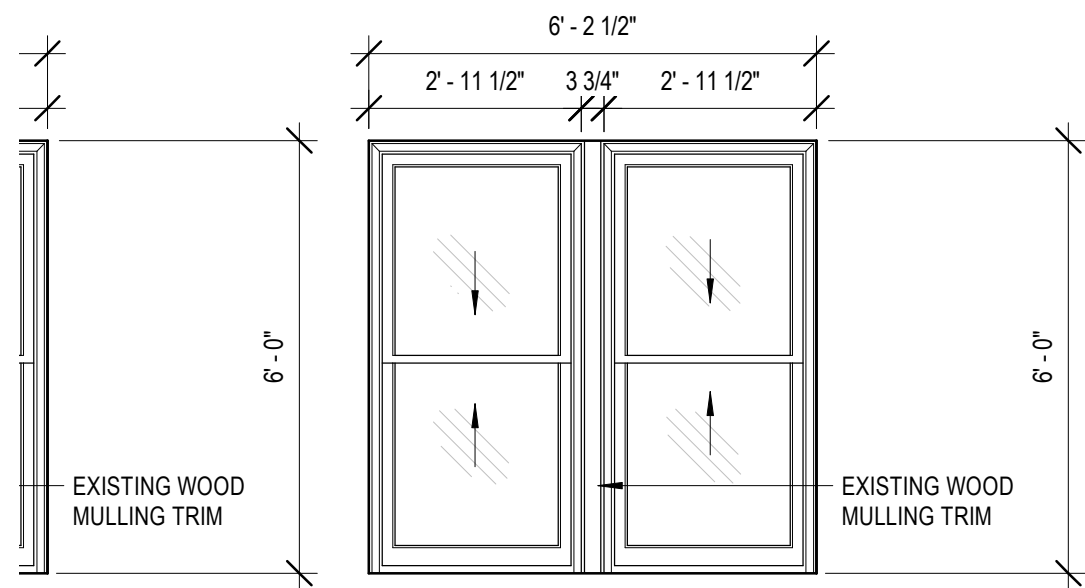

PROPOSED WINDOW:
MARVIN CLAD ULTIMATE DBL-HUNG G2

WINDOW 2F - EAST
VINYL DOUBLE-HUNG

WINDOW 2F - WEST (INTERIOR)
WOOD DOUBLE-HUNG

2F

SEE DETAILS ON SHEETS H.26 & H.29

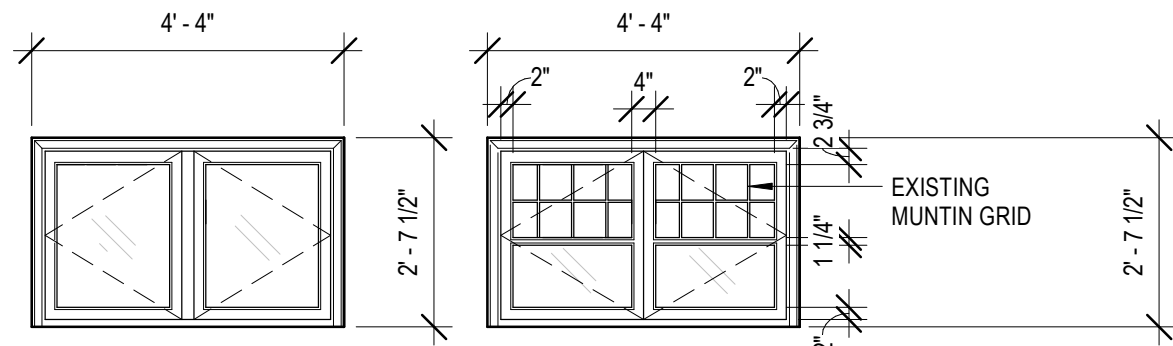

EXISTING WINDOW 3B EAST:
(2) VINYL CASEMENT

EXISTING WINDOW 3B WEST:
WOOD FRENCH INSWING CASEMENT

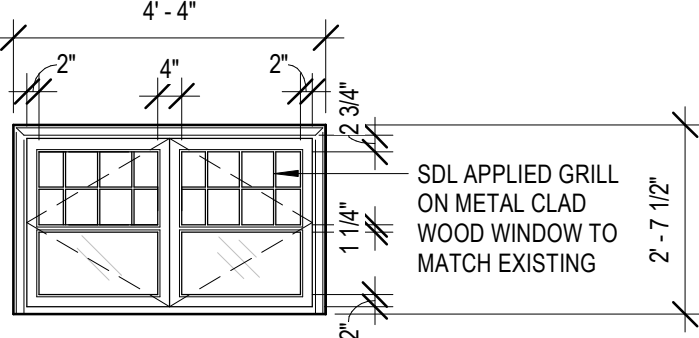

PROPOSED WINDOW:
MARVIN CLAD ULTIMATE INSWING CASEMENT G2
WITH SDL MUNTIN AND INTERNAL SPACER BAR



WINDOW 3B - EAST (INTERIOR)
(2) OUTSWING VINYL CASEMENT



WINDOW 3B - WEST:
WOOD INSWING FRENCH CASEMENT
WITH MUNTIN GRID

2 WINDOW TYPE 3B

H.22 | 3/8" = 1'-0"

SEE DETAILS ON SHEETS H.27 & H.28

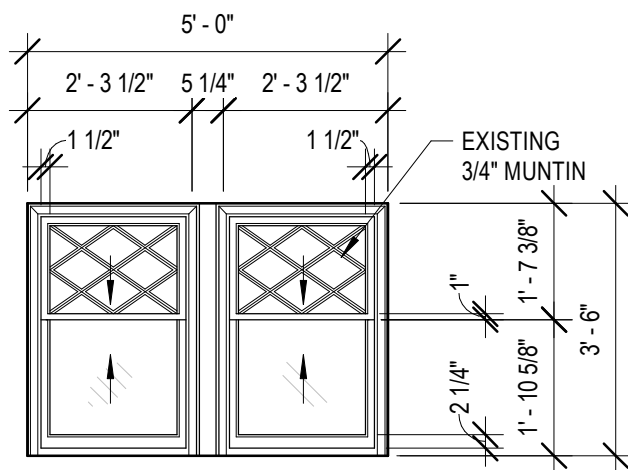

EXISTING WINDOW 2F:
EAST: (2) VINYL CASEMENT
WEST: (2) WOOD DOUBLE-HUNG

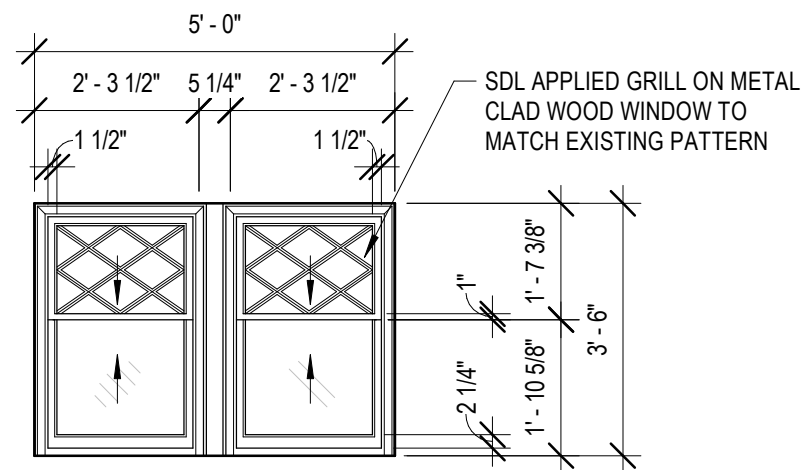

PROPOSED WINDOW:
MARVIN CLAD ULTIMATE DBL-HUNG G2
WITH SDL MUNTIN AND INTERNAL SPACER BAR



WINDOW 3A - EAST (INTERIOR)
VINYL CASEMENT



WINDOW 3A - WEST
WOOD DOUBLE-HUNG

1 WINDOW TYPE 3A

H.22 | 3/8" = 1'-0"

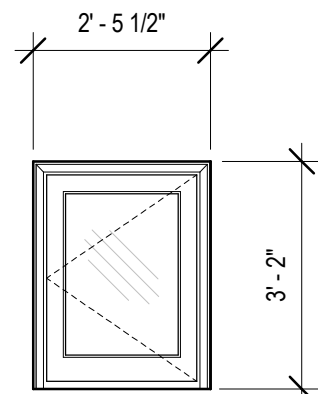

EXISTING WINDOW 3D EAST
VINYL CASEMENT

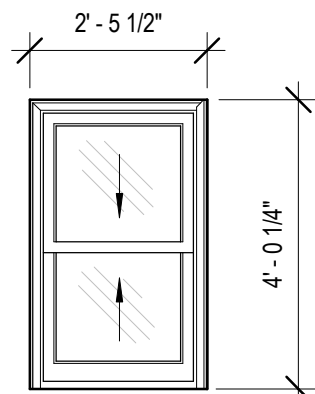

EXISTING WINDOW 3D WEST
WOOD DOUBLE-HUNG

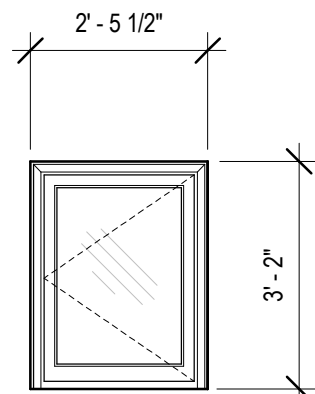

PROPOSED WINDOW 3D EAST
MARVIN CLAD ULTIMATE
CASEMENT

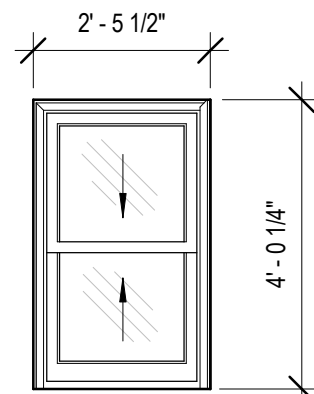

PROPOSED WINDOW 3D WEST
MARVIN CLAD ULTIMATE
DBL-HUNG G2



WINDOW 3D - EAST (INTERIOR)
OUTSWING VINYL CASEMENT



WINDOW 3D - WEST (INTERIOR)
WOOD DOUBLE-HUNG

2 WINDOW TYPE 3D

H.23 3/8" = 1'-0"

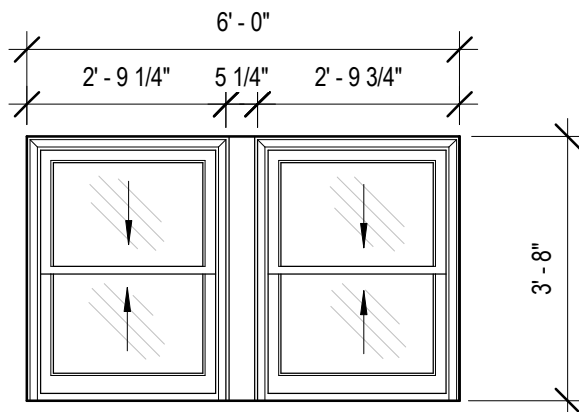

EXISTING WINDOW 2F:
EAST: VINYL DOUBLE-HUNG
WEST: WOOD DOUBLE-HUNG

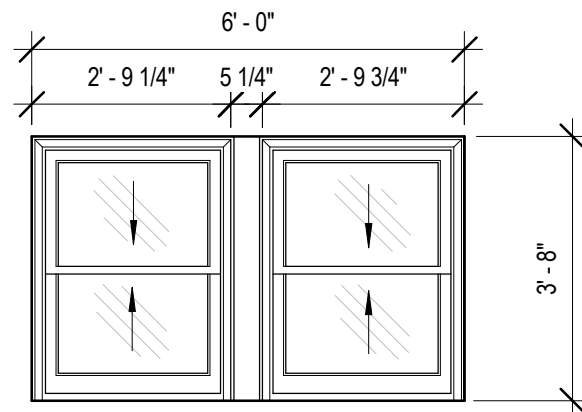

EXISTING WINDOW 2F:
EAST: VINYL DOUBLE-HUNG
WEST: WOOD DOUBLE-HUNG

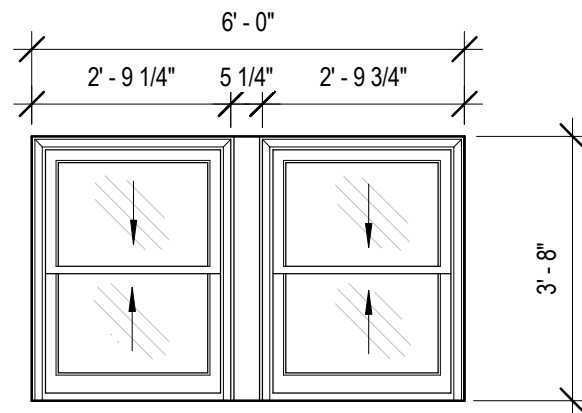

PROPOSED WINDOW:
MARVIN CLAD ULTIMATE DBL-HUNG G2



WINDOW 3C - EAST (INTERIOR)
(2) VINYL DOUBLE-HUNG



WINDOW 3C - WEST
(2) WOOD DOUBLE-HUNG

1 WINDOW TYPE 3C

H.23 3/8" = 1'-0"

SEE DETAILS ON SHEETS H.26 & H.29

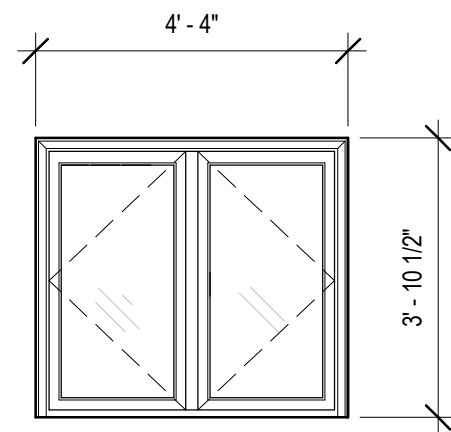

EXISTING WINDOW 3E EAST:
(2) VINYL CASEMENT

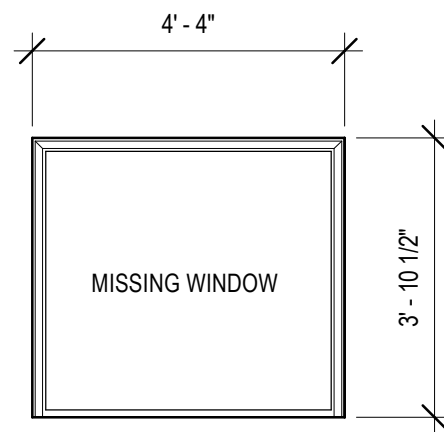

EXISTING WINDOW 3B WEST:
MISSING

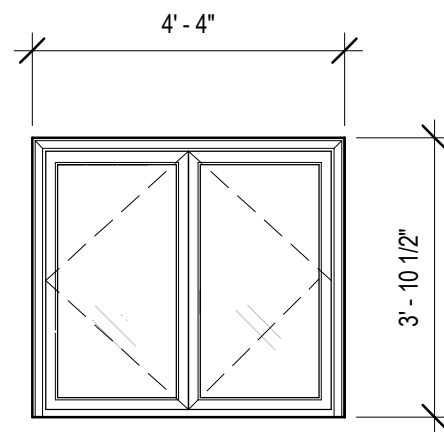

PROPOSED WINDOW:
MARVIN CLAD ULTIMATE FRENCH INSWING
CASEMENT G2



WINDOW 3E - EAST (INTERIOR)
(2) OUTSWING VINYL CASEMENT



WINDOW 3B - WEST (INTERIOR)
MISSING
ASSUMED FRENCH CASEMENT

1 WINDOW TYPE 3E

H.24 | 3/8" = 1'-0"

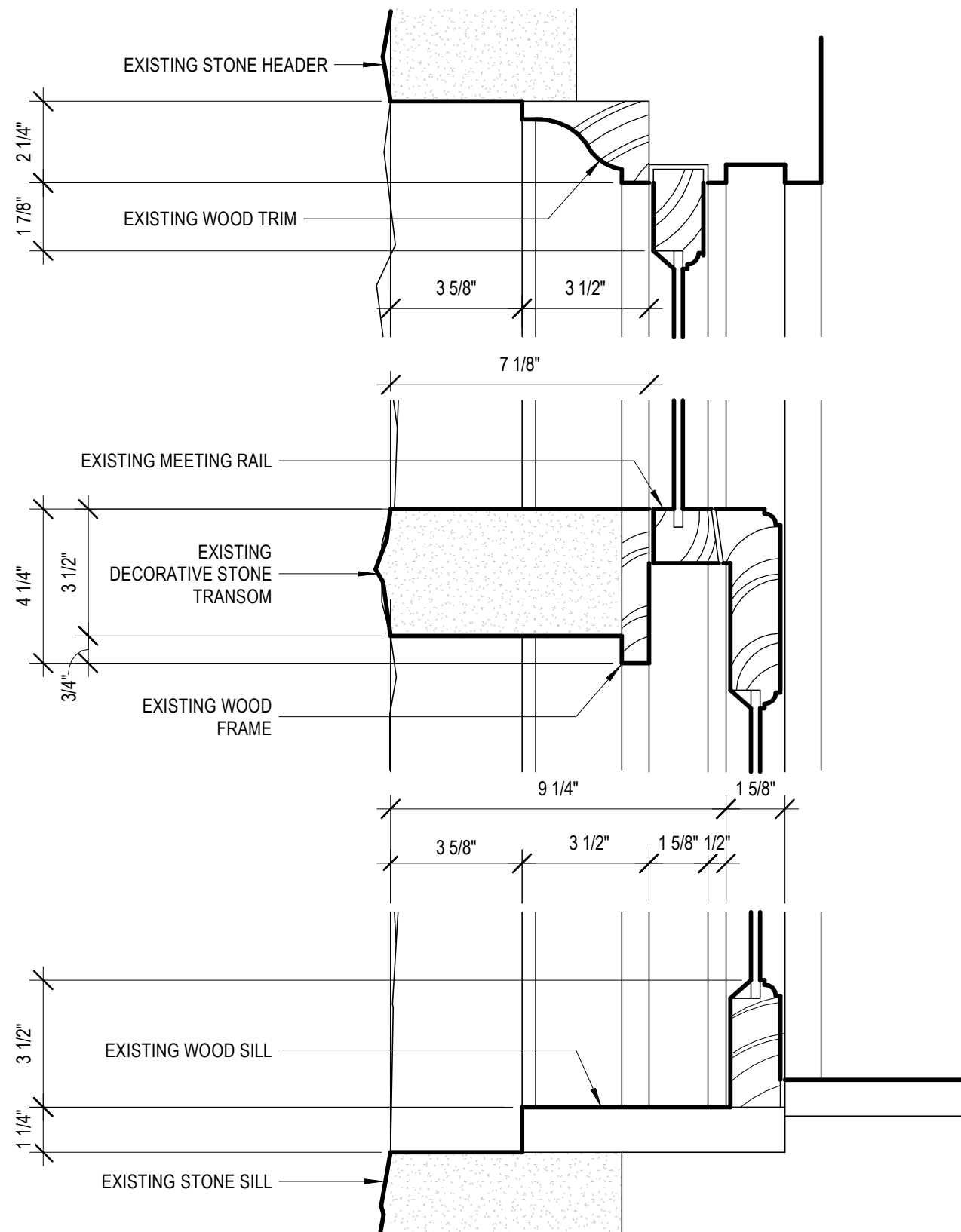

1 EXISTING WINDOW DETAIL - DH WITH TRANSOM

H.25 | 3" = 1'-0"

WINDOW TYPES 1A, 1B, 1C, 1D & 1E

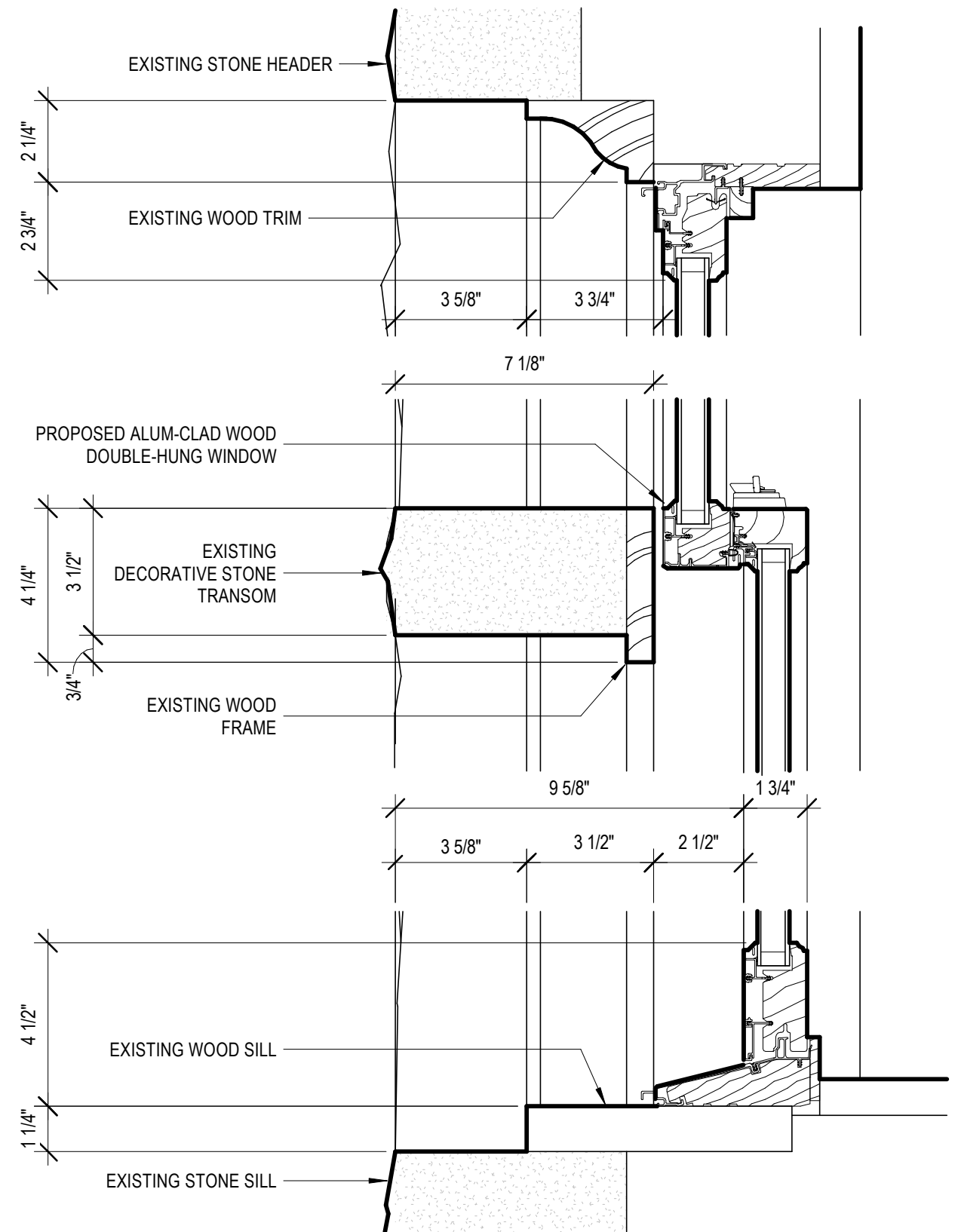

2 PROPOSED WINDOW DETAIL - DH WITH TRANSOM

H.25 | 3" = 1'-0"

WINDOW TYPES 1A, 1B, 1C, 1D & 1E

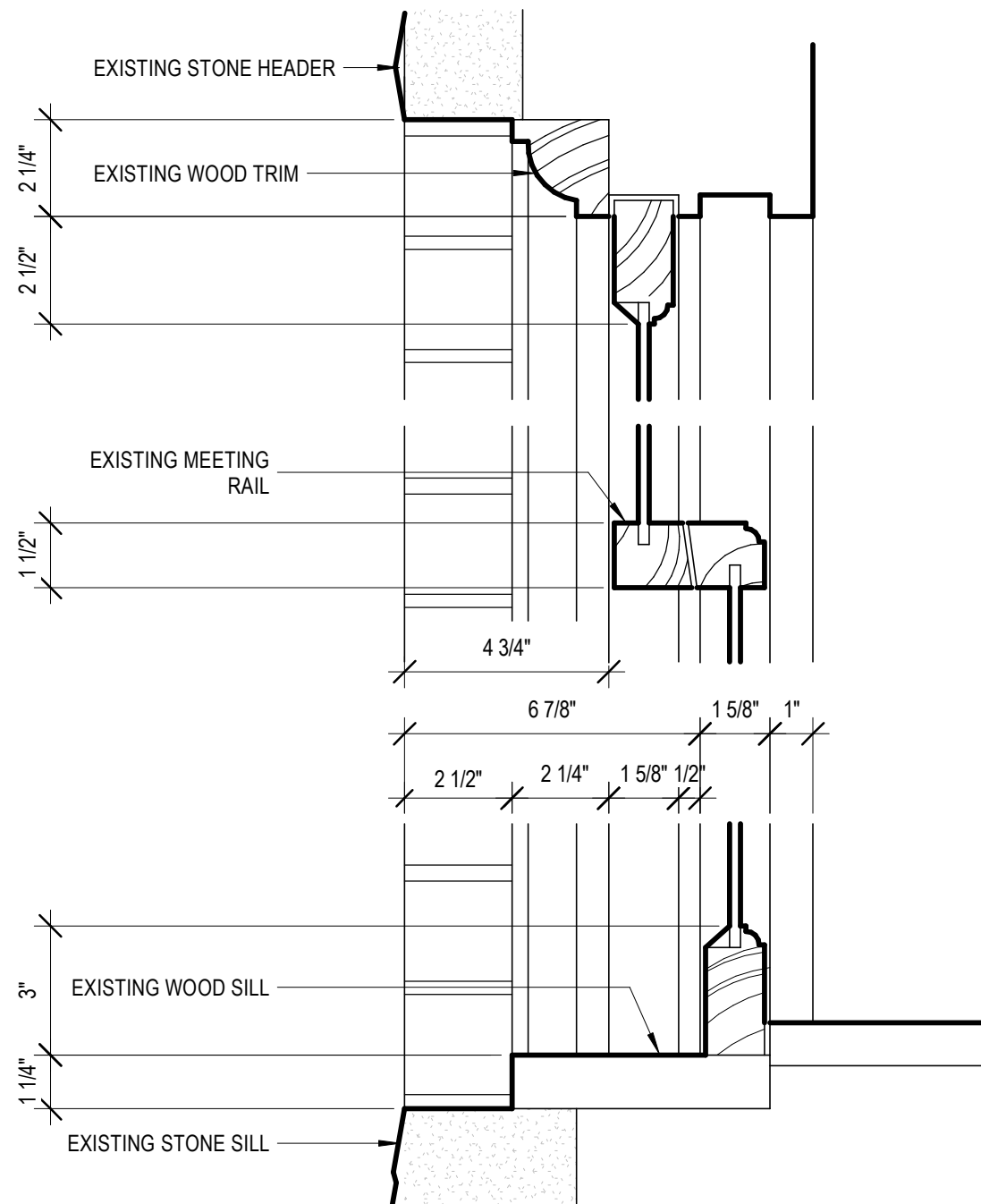

1 EXISTING WINDOW DETAIL - DOUBLE-HUNG

H.26 | 3" = 1'-0"

WINDOW TYPES 1A, 1B, 1C, 1D & 1E

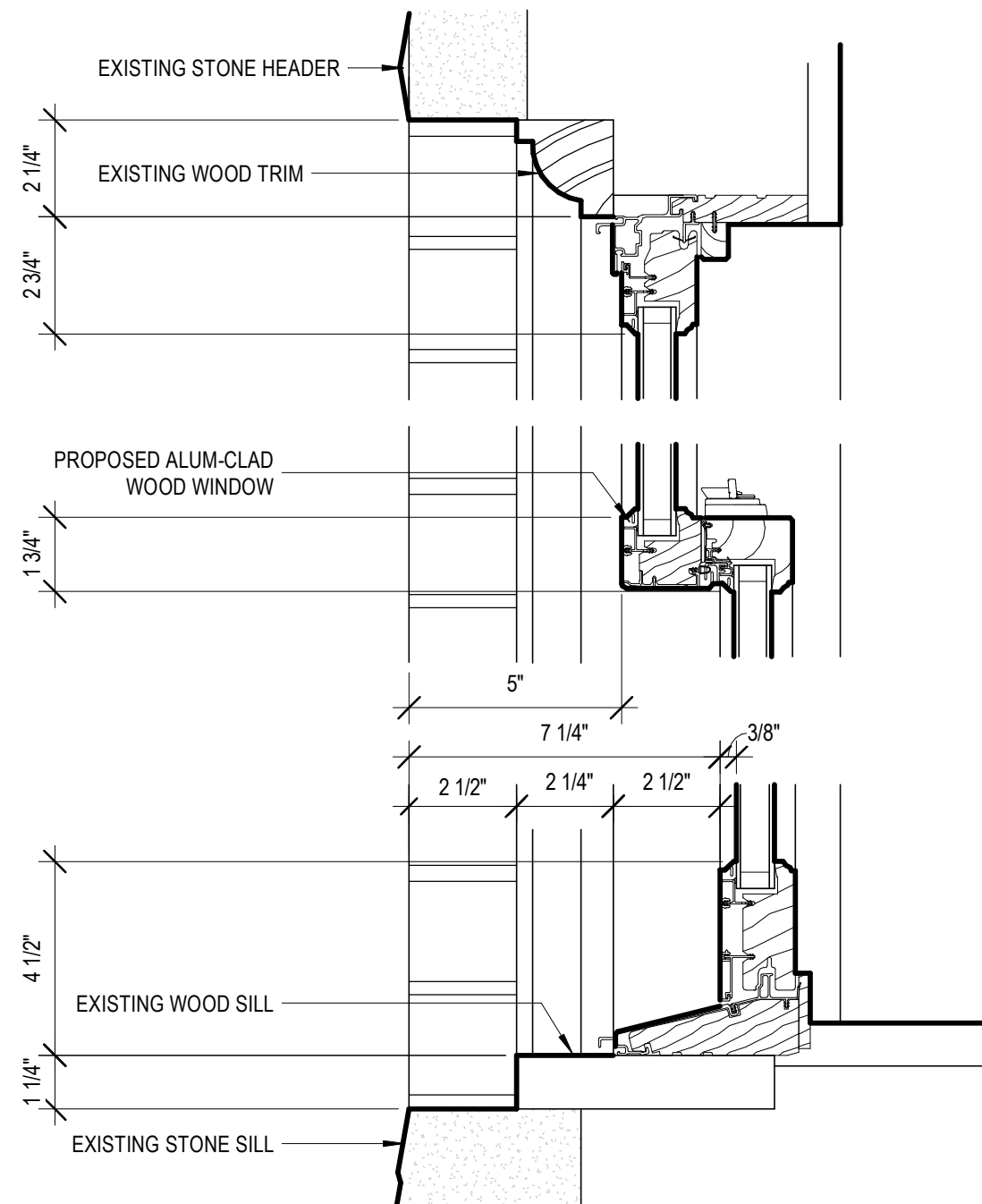

2 PROPOSED WINDOW DETAIL - DOUBLE HUNG

H.26 | 3" = 1'-0"

WINDOW TYPES 1A, 1B, 1C, 1D & 1E

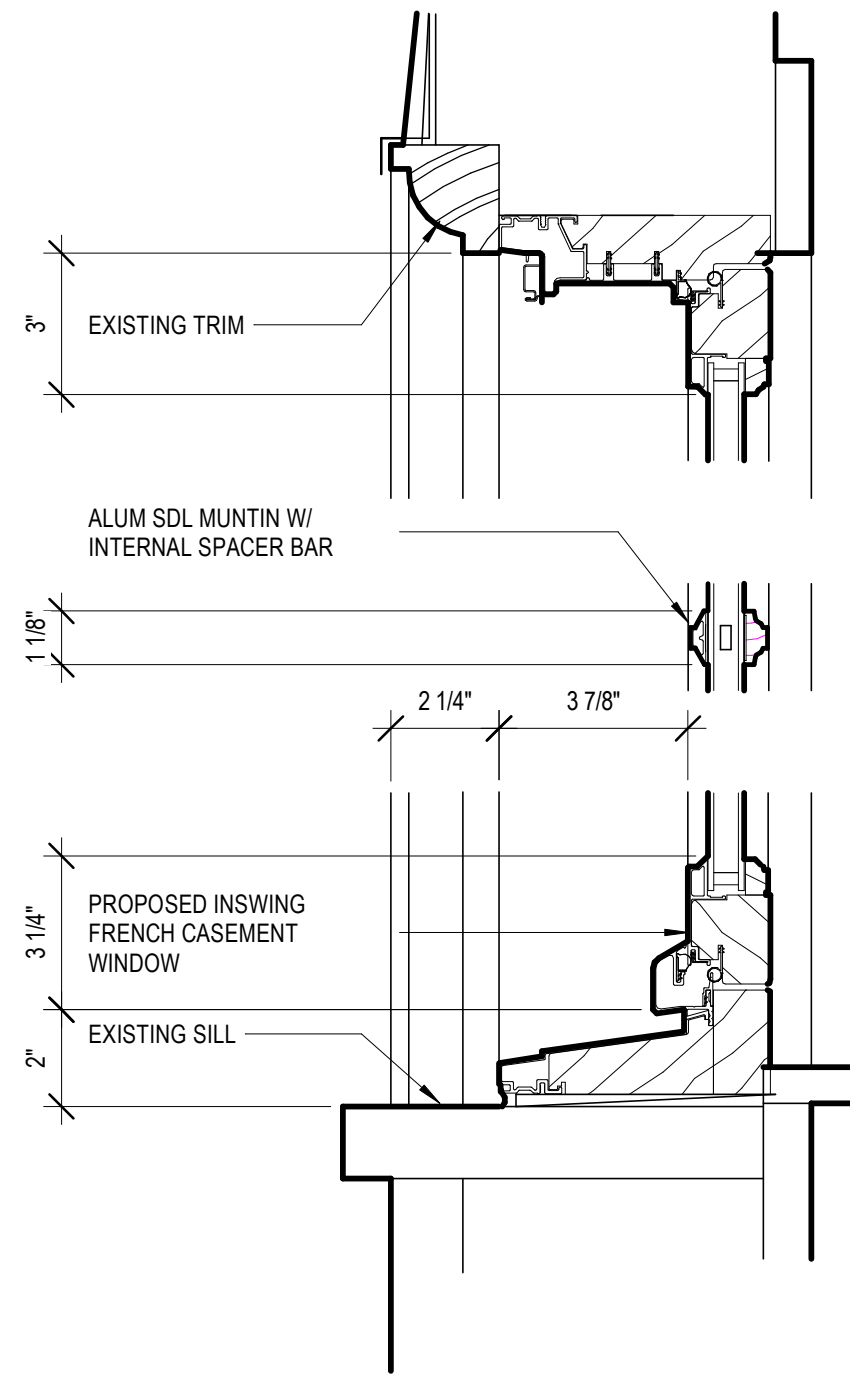
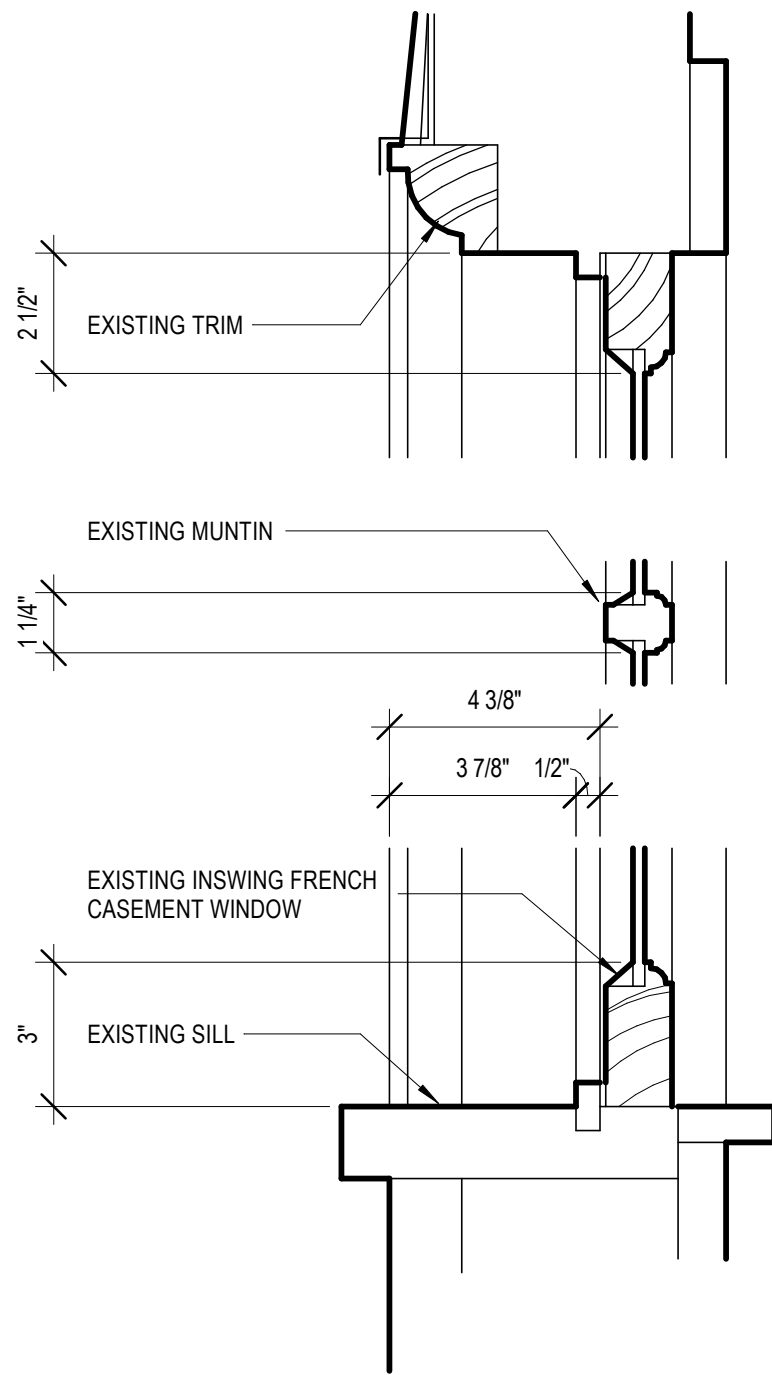

1 EXISTING WINDOW DETAIL - FRENCH CASEMENT

H.27 | 3" = 1'-0"

WINDOW TYPE 3B

2 PROPOSED WINDOW DETAIL - FRENCH CASEMENT

H.27 | 3" = 1'-0"

WINDOW TYPE 3B

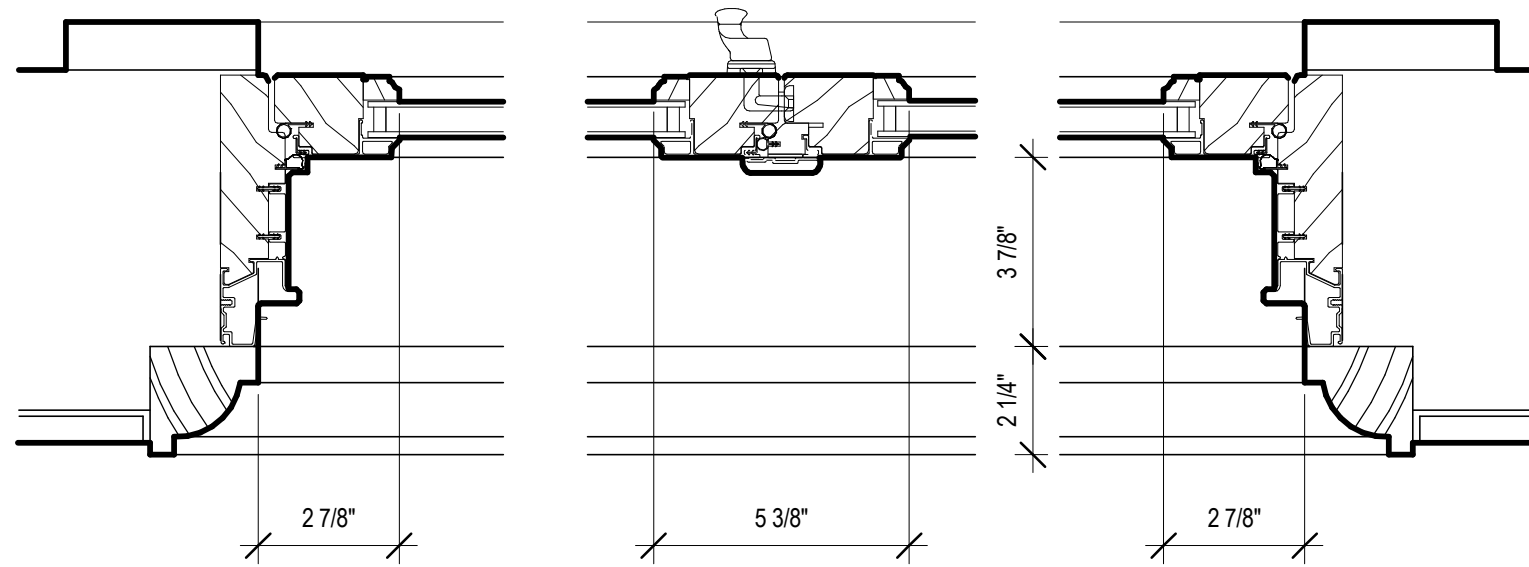

2 PROPOSED WINDOW JAMB DETAIL AT FRENCH CASEMENT

H.28 | 3" = 1'-0"

WINDOW TYPE 3B

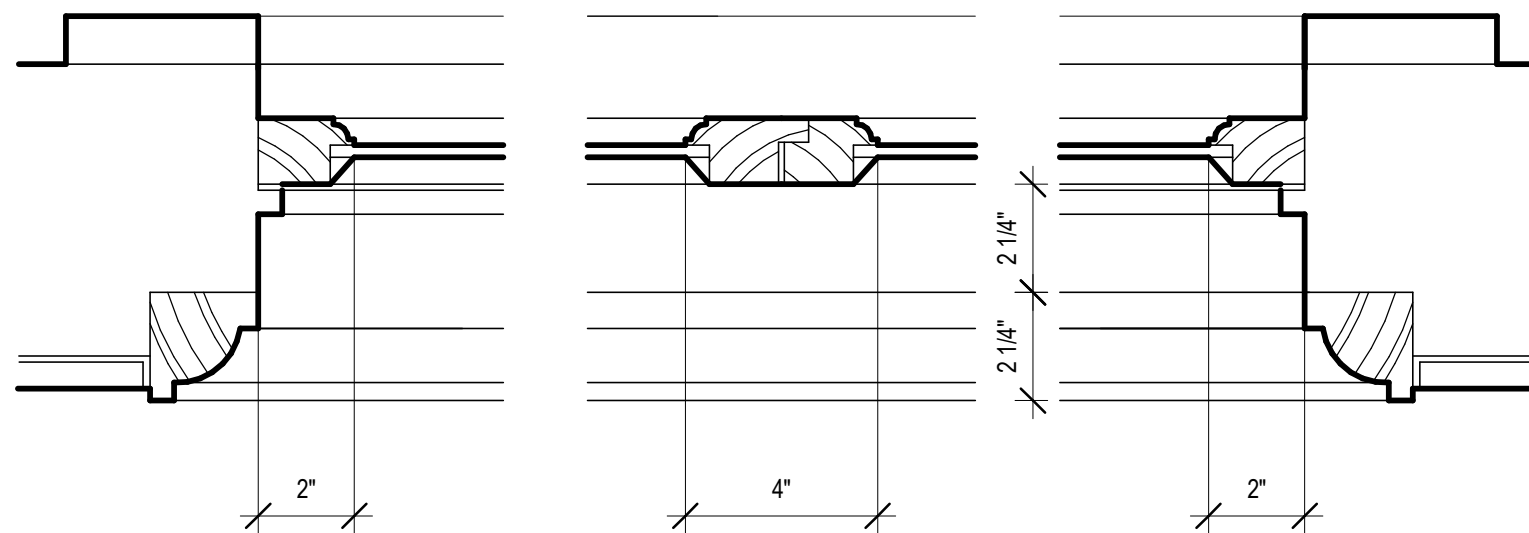

1 EXISTING WINDOW JAMB DETAIL AT FRENCH CASEMENT

H.28 | 3" = 1'-0"

WINDOW TYPE 3B

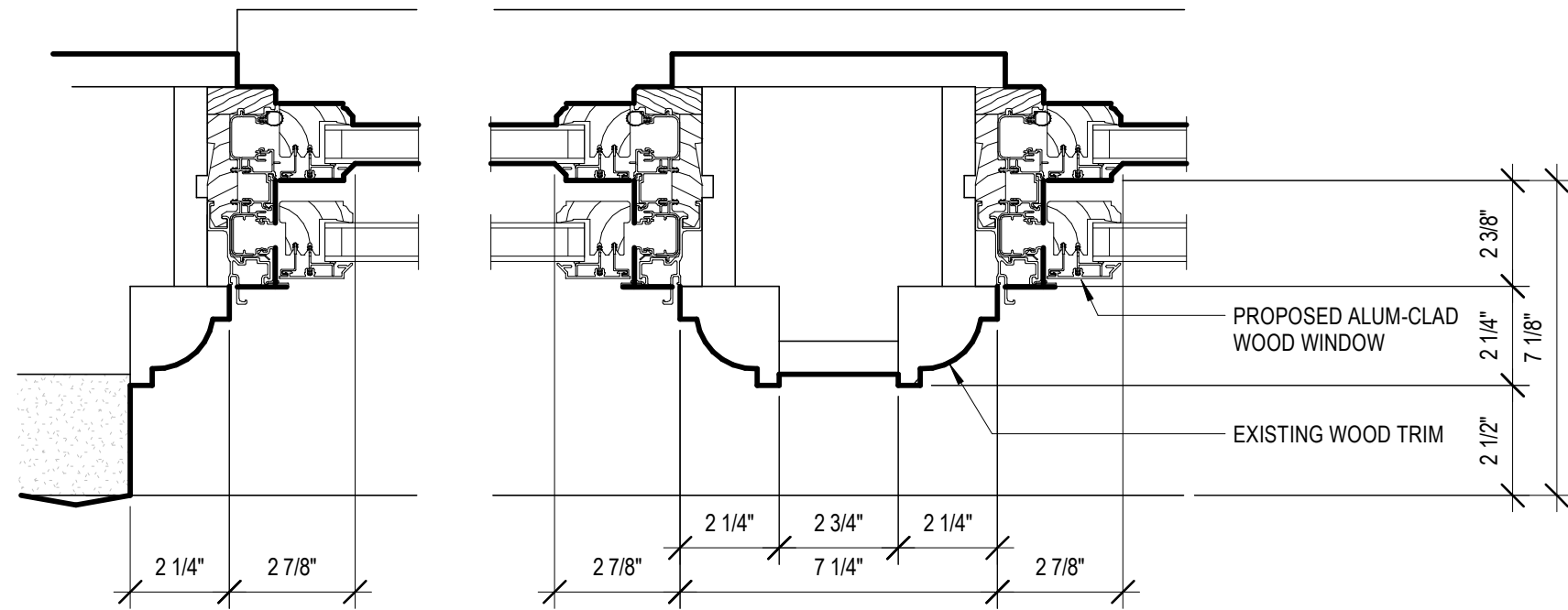

2 PROPOSED JAMB DETAIL - DOUBLE-HUNG

H.29 | 3" = 1'-0"

WINDOW TYPES 1F, 2F & 3A

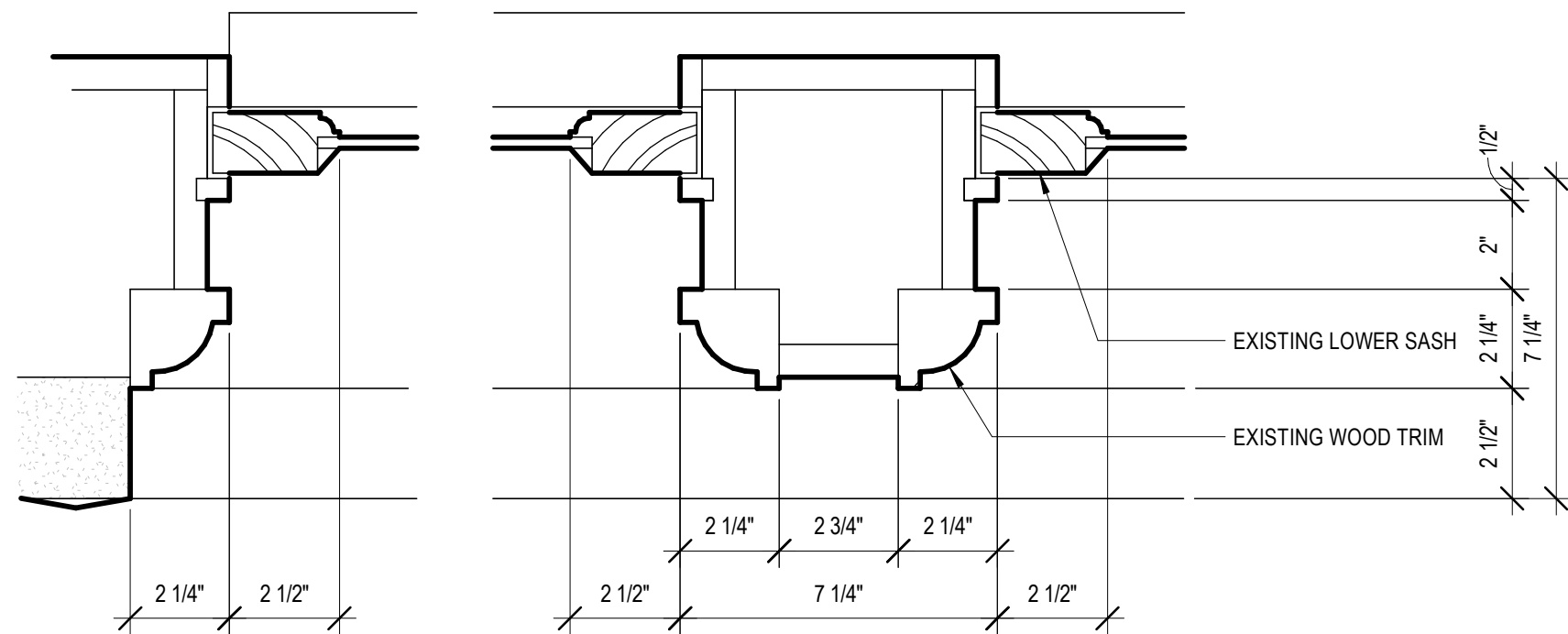

1 EXISTING JAMB DETAIL - DOUBLE-HUNG

H.29 | 3" = 1'-0"

WINDOW TYPES 1F, 2F & 3A

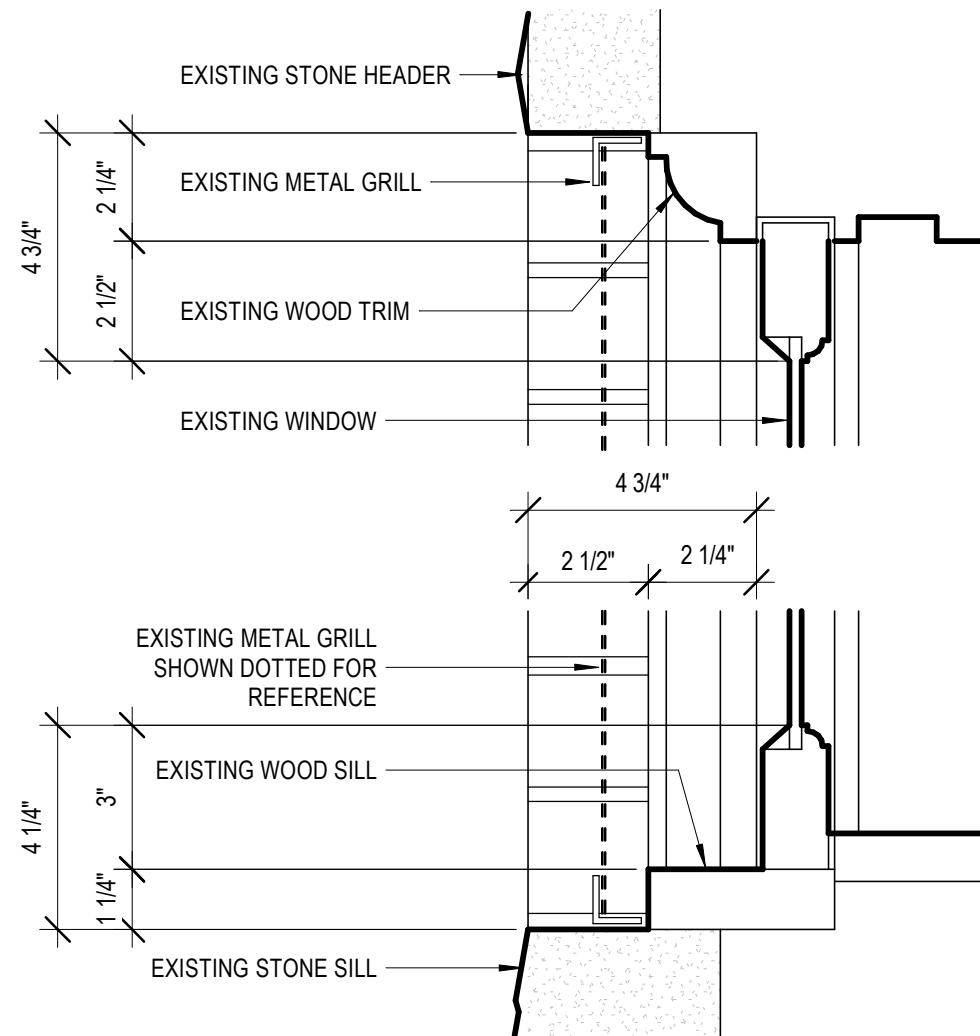

1 EXISTING BASEMENT WINDOW DETAIL

H.30 | 3" = 1'-0"

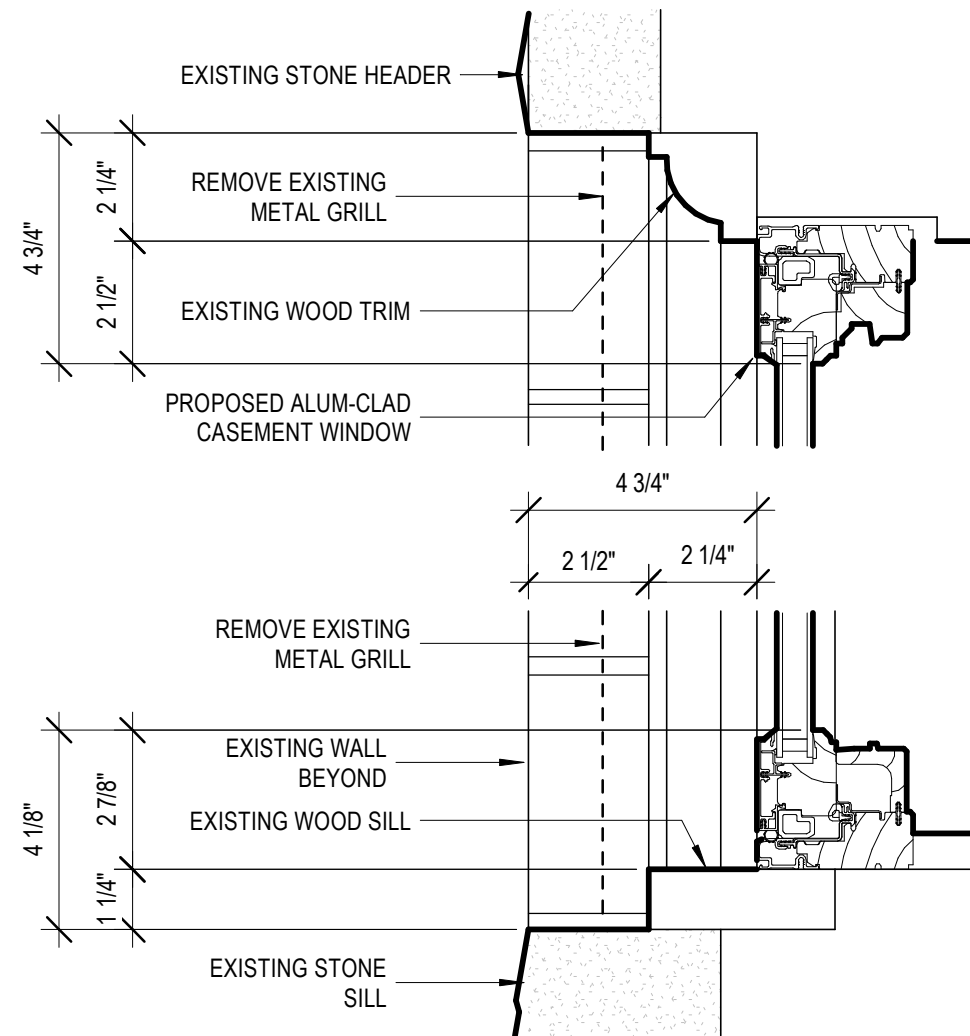

2 PROPOSED BASEMENT WINDOW DETAIL

H.30 | 3" = 1'-0"

Unit Features

Weather Strip:

- Operating units:
 - Jambs: Foam-filled bulb
 - Color: beige, black, and white
 - Head Jamb: Continuous dual leaf
 - Color: beige, black, and white
 - Check rail: Hollow bulb
 - Color: beige, black, and white
 - Bottom rail: Hollow bulb
 - Color: black
- Stationary units:
 - Jambs: Foam (picture), foam-filled bulb (transom)
 - Color: beige, black, white
 - Header and bottom rail: Hollow bulb
 - Color: black

Insect Screens:

- Standard screen frame is roll formed aluminum
- Aluminum screen: Full screen standard, half screen optional
- Aluminum surround to match exterior frame clad color
- Units with a glass height of 20" (508) or greater will have a center cross bar
- Screen mesh:
 - Standard: Charcoal Fiberglass
 - Optional: Charcoal High Transparency Fiberglass Mesh, Charcoal Aluminum Wire, Black Aluminum Wire, Bright Aluminum Wire, or Bright Bronze Aluminum Wire
- Optional Double Hung Magnum screen, extruded aluminum

Retractable Screen:

- Screen and its associated hardware shall fit within the frame, minimal exposure and shall not interfere with common window dressings
- Pull bar will protrude beyond the interior plane of the window
- Standard screen mesh: stiffened high transparency mesh
- Not available with Lift Lock option
- Optional pull bar latch hardware shall be available in beige, white, or black
 - Standard for Bare/Non Finger-Jointed Pine shall be beige
 - Standard for Prime and Painted Interior Finish shall be white
 - Standard for Mahogany and Cherry wood species shall be black
 - Standard for stained finish of Wheat or Honey shall be beige
 - Standard for stained finish of Hazelnut, Leather, Espresso, Cabernet shall be black
 - Pull bar fin is available in beige or black
 - Mesh retention pile is available in white or black
 - The standard is black unless PIF, Prime or Bare is chosen

Lock Status Sensor (Optional):

- Refer to **Lock Status Sensor Installation Instructions** for requirements.
- The Lock Status Sensor detects an open or closed status on Clad Ultimate Insert Double Hung - Next Generation 2.0 units and Clad Ultimate Insert Single Hung - Next Generation 2.0 units. A "locked" status is inferred from the presence of the Auto-Lock feature, which activate the locking mechanism when the operating panel is closed. It allows easy integration with home automation systems through a wired or wireless connection.
 - For wired option, check with local codes on potential contractor requirements for low voltage networking connections.
 - Wireless option available. Requires purchase of secondary transmitter for operation. Marvin will prep for this option.
- Wireless Lock Status Sensor is located within the width and height of the frame.
- Sensor Location
 - Will always be located on the right-hand side of the check rail (from the exterior) for the bottom sash. For the top sash, the sensor will be located in the header parting stop of the frame on the right side (from the exterior).
- For Wired or Wireless, Black or White Magnet Covers only visible on secondary surface. Cover color dependent upon interior finish.
 - White: Prime and White Painted Interior Finish
 - Black: Bare and all other finish options

Unit Features

Ultimate Casement Collection:

- Ultimate Casement (UCA), Ultimate Awning (UAWN), Ultimate Casement Picture (UCAP)
- Ultimate Casement Bows and Bays (UCABB), Ultimate Casement Round Top (UCART)
- Ultimate Push Out Casement (UCAPO), Ultimate Push Out Awning (UAWNPO)
- Ultimate Push Out Casement Picture (UCAPOP), Ultimate Push Out Casement Bows and Bays (UCAPOBB)
- Ultimate French Casement (UCAFR), Ultimate Push Out French Casement (UCAPOFR)
- Ultimate Venting Picture (UCAVP), Ultimate Casement Polygon (UCAPOLY)
- Ultimate Replacement Casement (UCANF), Ultimate Replacement Awning (UAWNNF)
- Ultimate Replacement Casement Picture (UCANFP)
- Ultimate Replacement Push Out Casement (UCANFPO), Ultimate Replacement Push Out Awning (UAWNNFPO)
- Ultimate Replacement Push Out Casement Picture (UCANFPOP)
- Ultimate Replacement Push Out French Casement (UCANFPOFR)
- Ultimate Replacement Casement Round Top (UCANFRT), Ultimate Replacement Casement Polygon (UCANFPOLY)

NOTE: Ultimate French Casement, Ultimate Push Out French Casement, Ultimate Venting Picture, Ultimate Replacement Casement Round Top, Ultimate Replacement Casement Polygon, and Ultimate Replacement Push Out French are not available with CE mark.

Bows and Bays are not available with CE mark from the factory. Bow and Bay kits are available for field mulling.

Frame:

- Frame thickness: 1 3/16" (30)
- Full frame units have a frame base (with pre-drilled installation holes in jambs): is 4 9/16" (116) from backside of nailing fin to interior wood face of frame
- Replacement frame: Units have overall base frame of 3 1/4" (83) jambs
- Frame bevel: Standard is no bevel, optional available are 8 degree bevel and 14 degree bevel

Sash:

- Nominal Sash thickness for full frame:
 - 1 5/8" (41) with 3/4" (19) insulating glass
 - 1 7/8" (48) with 1" (25) insulating glass
- Nominal Sash thickness for replacement frame: 1 5/8" (4) with 3/4" (19) insulating glass
- Stile and Rails 2 1/16" (52) standard
- Optional tall bottom rail 3 9/16" (90) available
- Standard interior wood cope sticking: Ogee
- Optional interior wood cope sticking: Ovolo and Square

Hardware: - See Individual Product Chapters

Interior Sticking Options:

- Standard interior sticking: Ogee
- Optional interior sticking: Square

Wood Interior Swinging Insect Screens:

- Wood screen surround: Matches window species.
- Screen mesh: Charcoal High Transparency (CH HI-Tran) fiberglass.
- Ball and Catch latch system used.
- Screen mesh options: Charcoal Fiberglass, Silver Gray Fiberglass, Charcoal Aluminum, Black Aluminum, Bright Aluminum and Bright Bronze.
- Standard Interior Sticking: Ogee
- Optional Interior Sticking: Square

Ogee

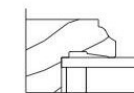

Square





MARVIN > SIGNATURE COLLECTION > MARVIN SIGNATURE™ ULTIMATE > ULTIMATE DOUBLE HUNG G2

ULTIMATE DOUBLE HUNG G2

Previously known as Clad Ultimate Double Hung-Next Generation

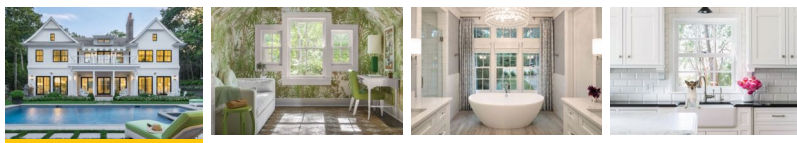

A contemporary classic, the Marvin Signature™ Ultimate Double Hung G2 window blends traditional beauty with state-of-the-art window performance. Reliable and energy efficient, the Ultimate Double Hung G2 window offers an auto-lock feature for convenient security, durable hardware for smooth operation and Marvin's unique wash mode for easy cleaning. Customize your design with round top styles or single hung operation with optional Lift Lock - Marvin's exclusive bottom rail locking mechanism for easier operation in hard-to-reach areas.

[VIEW DESIGN OPTIONS](#)

FOR THE PROS

Find technical documents for this product, including installation instructions, sizes and elevations, 3D drawings, architectural detail manuals and more.

[TECHNICAL SPECIFICATIONS](#)



INTERIOR

EXTERIOR

Features of the Ultimate Double Hung G2 Window

- Available in heights up to 10.5 feet or widths up to 5.5 feet
- Marvin's exclusive auto-lock activates when sashes are closed for convenient security
- Unique wash mode allows cleaning of both sides of glass from indoors
- Narrow checkrail maximizes view, while maintaining historical accuracy
- Retractable screen option is nearly invisible when the screen is not in use
- Available with the same features in a single hung style, with optional Lift Lock
- Additional configurations include round top, stationary transom or picture window
- Hidden Lock Status Sensor option connects with your smart home to indicate when windows are closed and locked
- Available with IZ3 coastal/hurricane certification
- Available with Commercial Windows Performance certification



ULTIMATE CASEMENT NARROW FRAME

Previously Known as Clad Ultimate Replacement Casement/Contemporary Casement

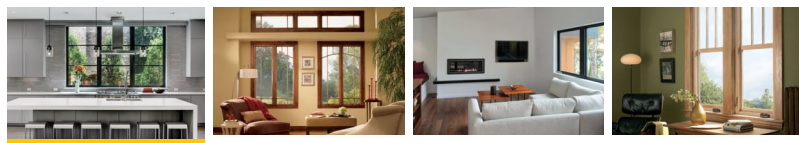

The Marvin Signature™ Ultimate Casement Narrow Frame window is a contemporary option with a flush exterior and narrow jamb ideal for frame-in-frame replacement, allowing quick and easy installation without disturbing the existing frame or interior wall. With its sleek design and square profiles, this window is a great fit for new construction or remodeling projects that call for slim lines and maximum views. With many design options, including round top shapes, the Ultimate Casement Narrow Frame window is a flexible option that can be sized to complement the most expansive views.

[VIEW DESIGN OPTIONS](#)

FOR THE PROS

Find technical documents for this product, including installation instructions, sizes and elevations, 3D drawings, architectural detail manuals and more.

[TECHNICAL SPECIFICATIONS](#)

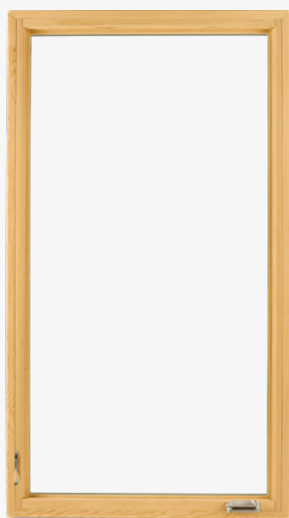

Features of the Ultimate Casement Narrow Frame Window

- Available in heights up to 8 feet or widths up to 3.5 feet
- Contemporary-style window with sleek design and square profiles
- Narrow jamb for replacement applications that minimizes tear-down of existing frame and walls
- Unique wash mode allows access to both sides of glass from indoors
- Retractable screen option is nearly invisible when the screen is not in use
- Hidden Lock Status Sensor option connects with your smart home to indicate when windows are closed and locked
- CE certified



ULTIMATE CASEMENT INSWING

Previously known as Marvin Inswing Casement



The Marvin Signature™ Ultimate Casement Inswing window complements classic architectural styles. Inswing casement windows can open into a room, making them a good choice when an outswing window could block or take up valuable space on patios, decks or outdoor walkways. Available by special order in single or French double-sash styles.

[VIEW DESIGN OPTIONS](#)

FOR THE PROS

Find technical documents for this product, including installation instructions, sizes and elevations, 3D drawings, architectural detail manuals and more.

[TECHNICAL SPECIFICATIONS](#)



Features of the Ultimate Casement Inswing Window

- Available in heights up to 6 feet or widths up to 4 feet
- Choose from single-sash or French double-sash styles
- French Inswing Casement eliminates vertical center post for wide-open views
- Available in large sizes to maximize views and architectural impact
- Optional concealed pocket hinges provide clean look and smooth operation
- CE certified in clad material

INTERIOR

EXTERIOR