

October 21, 2020

Leopoldo Hernandez
1035 Clark
Detroit MI 48209

RE: Application Number 20-6883; 1035 Clark: Hubbard Farms Historic District

Dear Mr. Herndandez:

At the regularly scheduled meeting held virtually on October 14, 2020, the Detroit Historic District Commission ("Commission") reviewed the above-referenced application for building permit.

NOTICE OF DENIAL

Pursuant to Section 21-2-80 of the 2019 Detroit City Code, the Commission hereby issues a **Notice of Denial** which is effective as of October 21, 2020. The Commission finds the proposed work *does not* qualify for a Certificate of Appropriateness for the following reasons:

The removal of the existing windows and installation of new windows, as proposed in the attached application, does not meet the defined elements of design for the historic district nor the Secretary of the Interior's Standards for Rehabilitation, especially 2) *The historic character of a property shall be retained and preserved. The removal of historic materials or alteration of features and spaces that characterize a property shall be avoided;* 5) *Distinctive features, finishes, and construction techniques or examples of craftsmanship that characterize a property shall be preserved;* 6) *Deteriorated historic features shall be repaired rather than replaced. Where the severity of deterioration requires replacement of a distinctive feature, the new feature shall match the old in design, color, texture, and other visual qualities and, where possible, materials. Replacement of missing features shall be substantiated by documentary, physical, or pictorial evidence;* and 9) *New additions, exterior alterations, or related new construction shall not destroy historic materials that characterize the property. The new work shall be differentiated from the old and shall be compatible with the massing, size, scale, and architectural features to protect the historic integrity of the property and its environment.*

NOTICE TO PROCEED

Pursuant to MCL 399.205 and Section 21-2-75 of the 2019 Detroit City Code, the Detroit Historic District Commission ("Commission") has reviewed the above-referenced application for building permit and has issued a Notice to Proceed effective as of October 21, 2020.

Removal of the existing windows and windows jambs and the installation of new wood, aluminum-clad windows without the required documentation showing the existing wood windows are beyond repair, is inappropriate to the historic district. However, as the property falls within the service area of the Bridging Neighborhoods I-75 Environmental Mitigation Program, and the property owners have been offered home mitigations to address noise and air quality impacts from increased truck traffic related to the Gordie Howe International Bridge Project, the following condition prevails:

- (2) The resource is a deterrent to a major improvement program that will be of substantial benefit to the community. Substantial benefit shall be found only if the applicant proposing to do the work has obtained all necessary planning and zoning approvals, financing, and environmental clearances and the improvement program is otherwise feasible.

Please note this Notice to Proceed has been issued with the following conditions:

- The existing windows will remain in place until the replacement windows are approved by Commission staff.
- The new window frame dimensions shall not increase more than ¼-inch (from the existing wood frame dimensions).
- The operation and glass within each new window unit will match the existing window. The dominant window style is double-hung, with one-over-one wood sash. Exceptions to this condition include:
 - First floor, front elevation, center bay fixed wood frame window with transom above.
 - First floor, side elevation, fixed wood frame window and leaded glass transom above.
 - First floor, sides and rear, four replacement wood double-hung (one-over-one) vinyl clad windows (three on addition, one on south elevation of house).
 - Second floor, rear elevation, vinyl frame sliding window.
 - Third floor, rear elevation, two square casements (each with a two-over-two muntin pattern) and wood mullion
- The existing casings, inner stop, and brick mould will be retained and will remain in their current condition.
- The leaded glass transom window will remain in place and be repaired as needed. A storm window may be installed to mitigate noise.
- Existing wood mullions, if present, will remain in place. New, single window units will be inserted into existing window openings.
- The casement windows will have a simulated divided light muntin pattern.
- The new windows will be solid wood (exterior to be painted) **or** solid wood, aluminum-clad units. The exterior frame color will be submitted for review.
- The existing exterior wood brick mould will be retained and will remain covered with aluminum.

If any of the above conditions not be met, HDC staff will require the applicant to submit a revised proposal for the Commission's review at an upcoming meeting.

Please retain this Notice to Proceed for your files. You should now proceed to obtain a building permit from the City of Detroit Buildings and Safety Engineering Department. It is important to note that approval by the Detroit Historic District Commission does not waive the applicant's responsibility to comply with any other applicable ordinance or statute.

On behalf of the commission:



Audra Dye
Staff
Detroit Historic District Commission

THIS IS A 3-PAGE FORM - ALL INFORMATION IS REQUIRED FOR PROJECT REVIEW

HISTORIC DISTRICT COMMISSION PROJECT REVIEW REQUEST

City of Detroit - Planning & Development Department
2 Woodward Avenue, Suite 808
Detroit, Michigan 48226

Date: 8/20/2020

PROPERTY INFORMATION

ADDRESS: 1035 Clark Street AKA: _____

HISTORIC DISTRICT: Hubbard Farms

SCOPE OF WORK: (Check ALL that apply)
 Windows/Doors Roof/Gutters/Chimney Porch/Deck Landscape/Fence/Tree/Park General Rehab
 New Construction Demolition Addition Other: _____

APPLICANT IDENTIFICATION

Property Owner/Homeowner Contractor Tenant or Business Occupant Architect/Engineer/Consultant

NAME: Logesh Rajendran COMPANY NAME: DMC Consultants, Inc

ADDRESS: 13500 Foley CITY: Detroit STATE: MI ZIP: 48209

PHONE: 3134911815 MOBILE: _____ EMAIL: logeshr@dmconsultantsusa.com

PROJECT REVIEW REQUEST CHECKLIST

Please attach the following documentation to your request:

PLEASE KEEP FILE SIZE OF ENTIRE SUBMISSION UNDER 30MB

Completed Building Permit Application (highlighted portions only)

ePLANS Permit Number (only applicable if you've already applied for permits through ePLANS)

Photographs of ALL sides of existing building or site

Detailed photographs of location of proposed work (photographs to show existing condition(s), design, color, & material)

Description of existing conditions (including materials and design)

Description of project (if replacing any existing material(s), include an explanation as to why replacement--rather than repair--of existing and/or construction of new is required)

Detailed scope of work (formatted as bulleted list)

Brochure/cut sheets for proposed replacement material(s) and/or product(s), as applicable

NOTE:

Based on the scope of work, additional documentation may be required.

See www.detroitmi.gov/hdc for scope-specific requirements.

Upon receipt of this documentation, staff will review and inform you of the next steps toward obtaining your building permit from the Buildings, Safety Engineering and Environmental Department (BSEED) to perform the work.

SUBMIT COMPLETED REQUESTS TO HDC@DETROITMI.GOV

1035 Clark

City of Detroit

Bridging Neighborhoods

I-75 Environmental Mitigation Program



Description of Project

The Bridging Neighborhoods Program was created by City Council Resolution and approved by the Mayor on July 26, 2017.

The home for which this application was created falls within the service area of the I-75 Environmental Mitigation Program which, per Exhibit A Item H. of the resolution is required to provide a “retrofit package designed to protect occupants of the Retrofit-Eligible Home from air pollution and noise pollution.... Retrofit packages may include new windows; air filters; insulation; and/or heating, ventilation, and air conditioning systems.”

Because of the requirement to provide new windows, we seek permission to replace the existing windows.

Description of Existing Conditions

The property at 1035 Clark street has existing single pane, double hung wood windows.

As you review the provided images, you will see that these windows are in various states of repair.

The windows all have exterior white paint.

Window C1 and C2 are casement windows

Window C3- Vinyl window

Window C4, B4, B5 and D4 are wood windows with vinyl cladding outside.

NOT TO SCALE

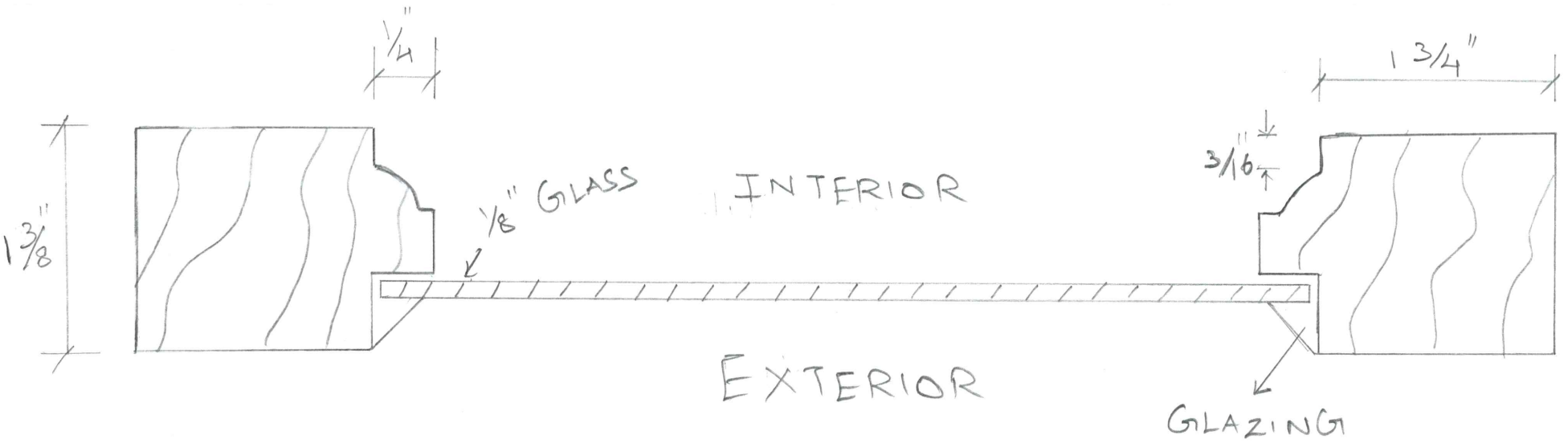

EXISTING SASH DETAILS

1035 CLARK and 1041 CLARK

NOT TO SCALE

EXISTING MEETING RAIL

1035 CLARK AND

1041 CLARK

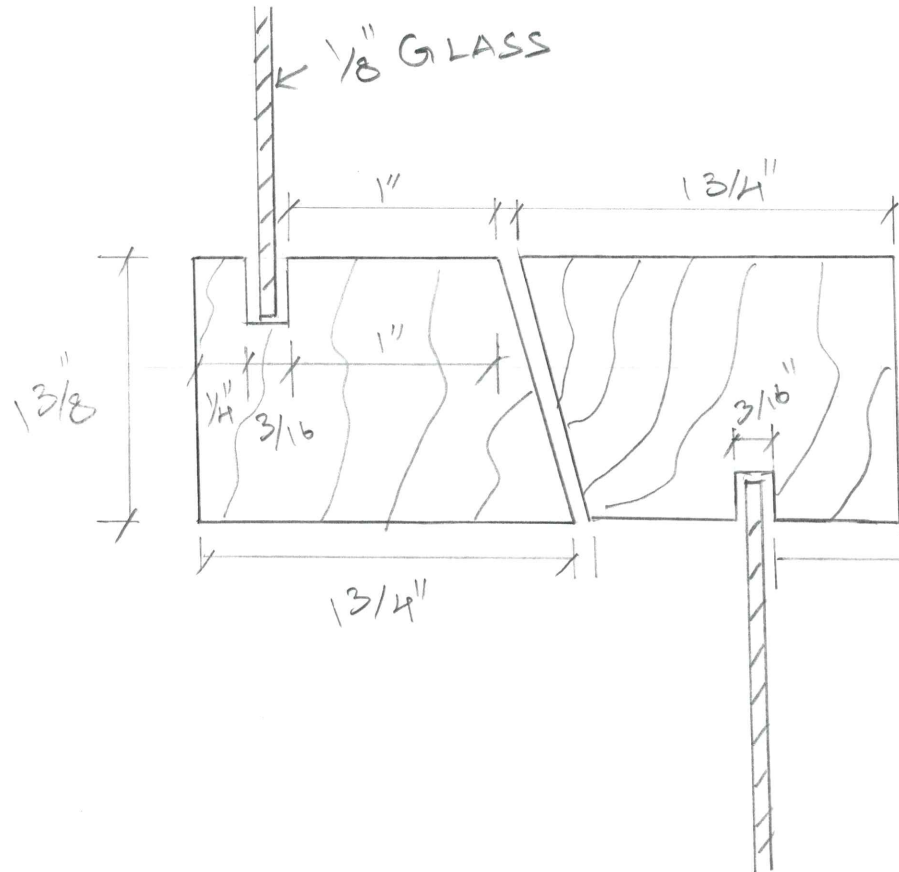

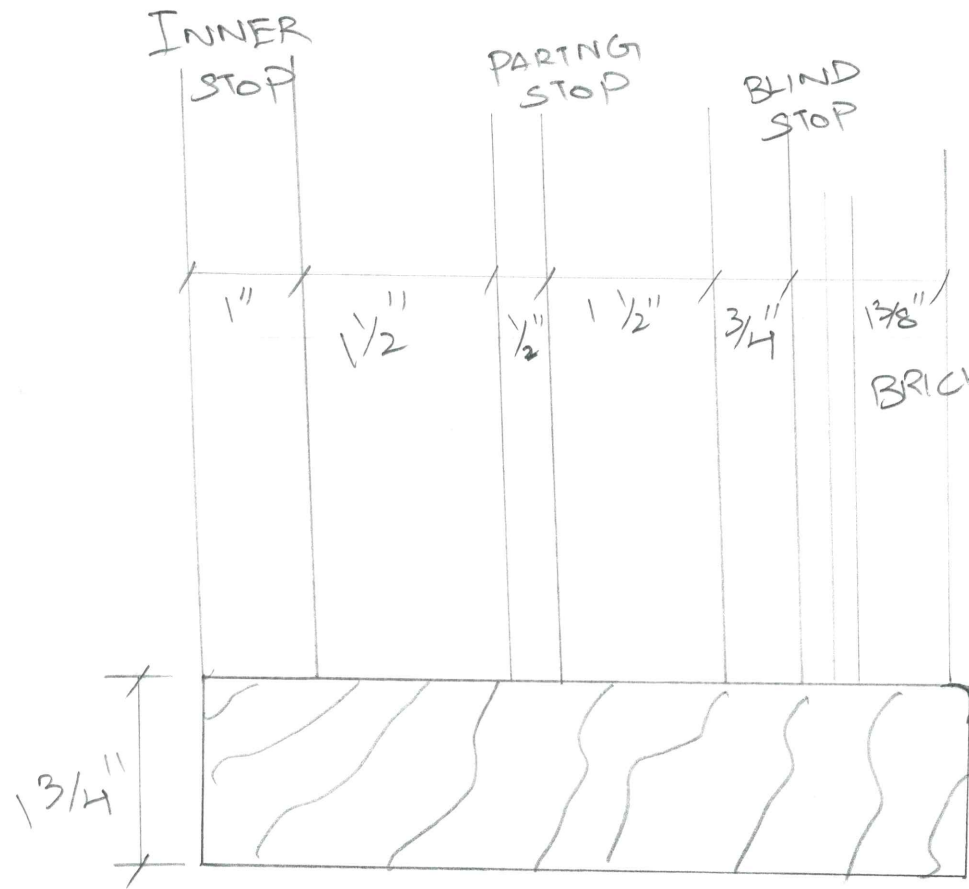

BRICK MOLD WRAPPED WITH ALUMINUM TRIM COIL

EXISTING SILL AND JAMB

CASEMENT WINDOW - IOBS CLARK

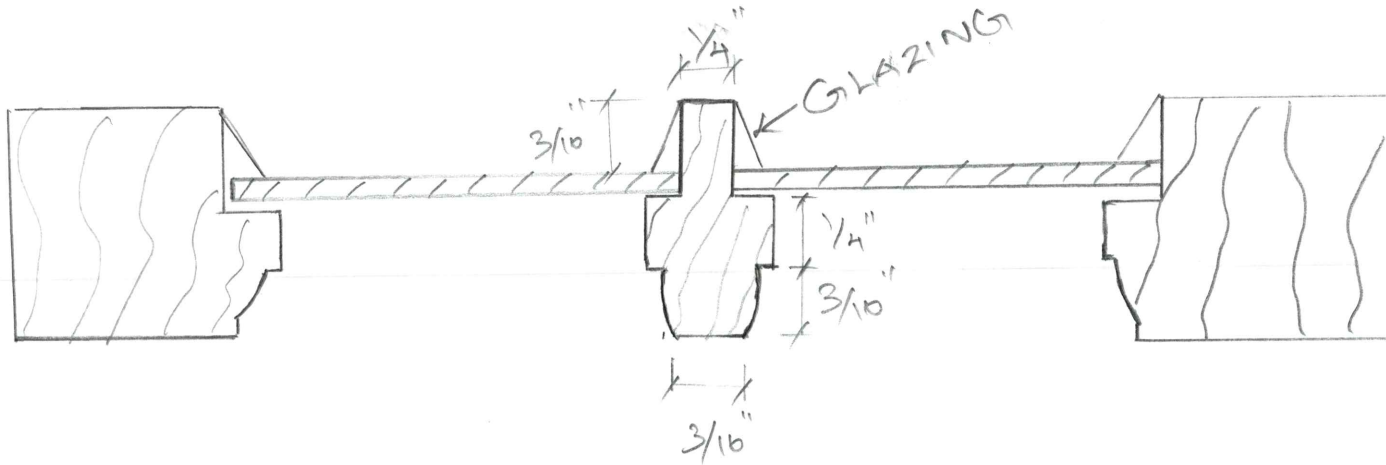

1035 CLARK

EXISTING BRICK MOLD - COVERED
WITH ALUMINUM TRIM

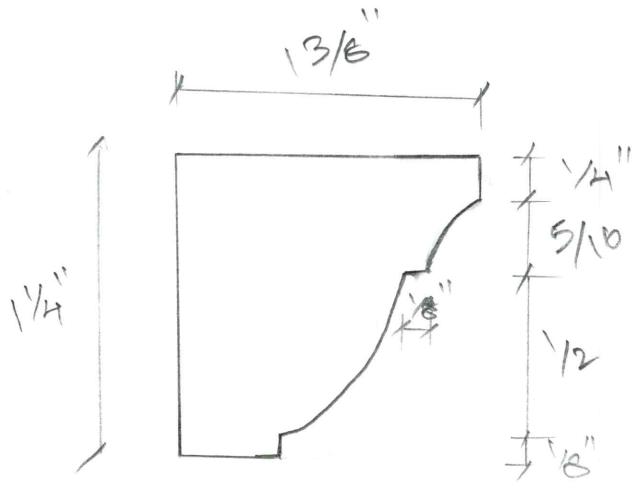

Scope of Work

- Replacing existing wood windows with new STC 27 wood windows. Interior casings and stops will be retained. Exterior brick mold is covered with white aluminum trim outside (refer to the pictures attached).

Brochure/Cut Sheet

Weather Shield®

Weather Shield Series™

Double Hung Windows

CROSS SECTION DETAILS

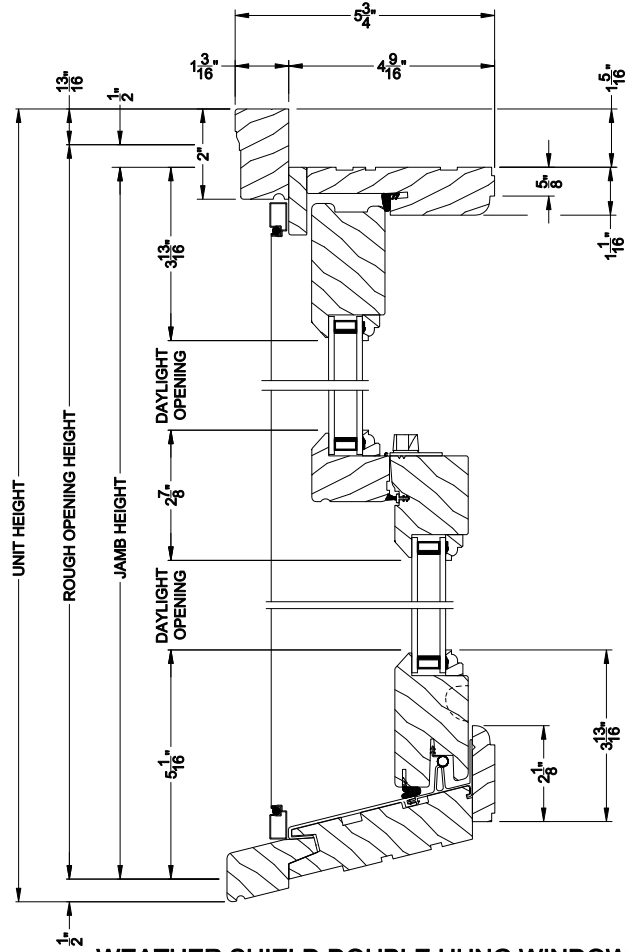

WEATHER SHIELD DOUBLE HUNG WINDOW (610)
Vertical Section

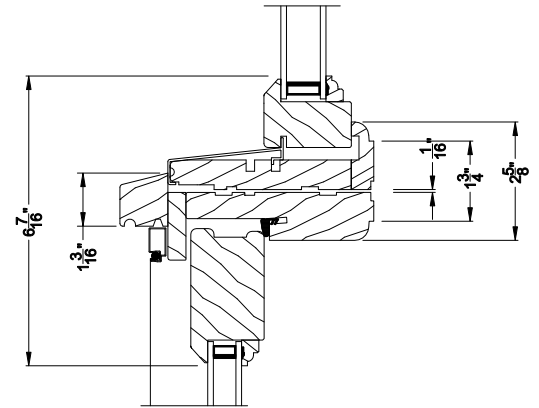

WEATHER SHIELD DOUBLE HUNG WINDOW
Horizontal Stack Section - Transom Stack over DH

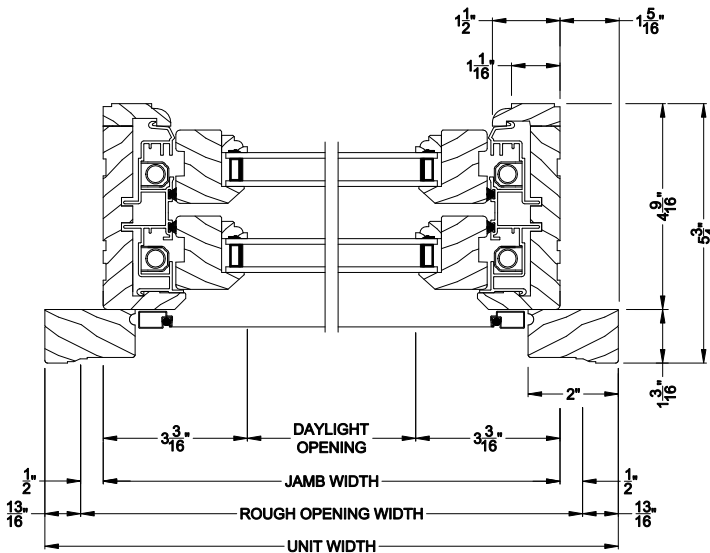

WEATHER SHIELD DOUBLE HUNG WINDOW (610)
Horizontal Section

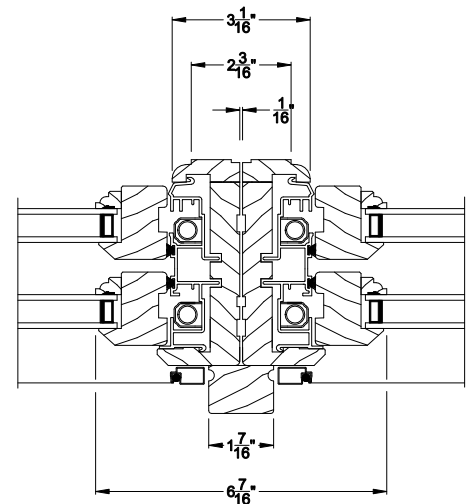

WEATHER SHIELD DOUBLE HUNG WINDOW
Vertical Mull Section - DH / DH

Note: All dimensions are approximate. Weather Shield reserves the right to change specifications without notice.

Weather Shield®

Weather Shield Series™

Double Hung Windows

CROSS SECTION DETAILS

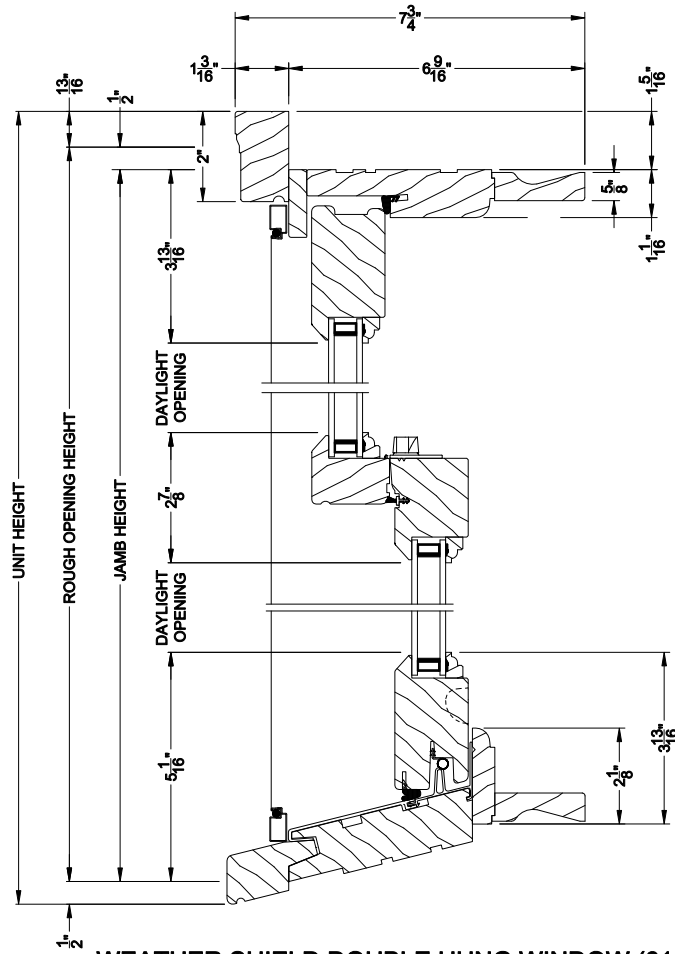

WEATHER SHIELD DOUBLE HUNG WINDOW (610)
Vertical Section - 6-9/16" jamb

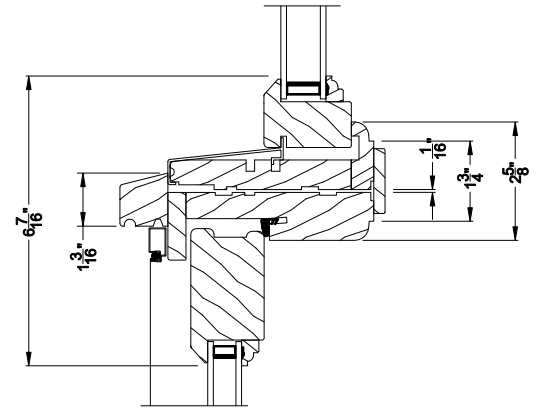

WEATHER SHIELD DOUBLE HUNG WINDOW
Horizontal Stack Section - Transom Stack over DH

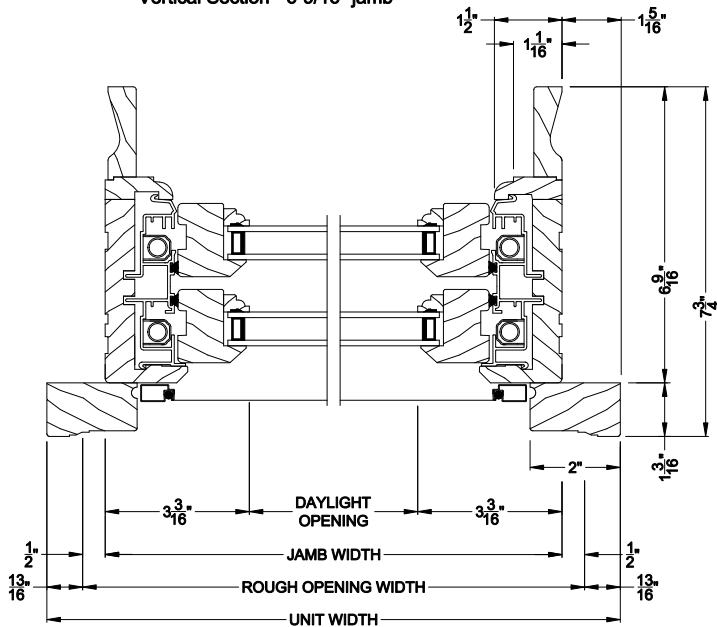

WEATHER SHIELD DOUBLE HUNG WINDOW (610)
Horizontal Section - 6-9/16" jamb

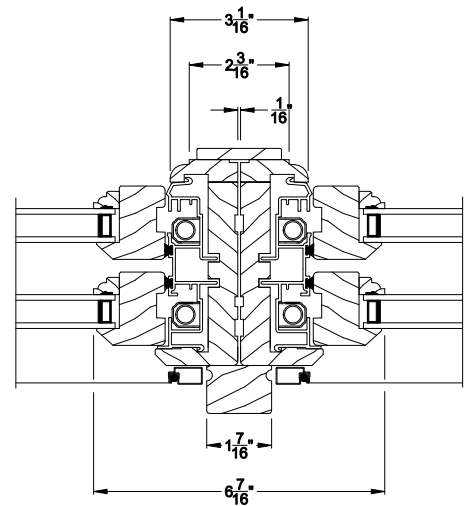

WEATHER SHIELD DOUBLE HUNG WINDOW
Vertical Mull Section - DH / DH

Note: All dimensions are approximate. Weather Shield reserves the right to change specifications without notice.



EXTERIOR COLOR OPTIONS

To help you get the exact look you desire, we offer an ever-expanding palette of durable and distinct exterior color options rated to the highest industry standards (AAMA 2605) for color retention. Our Premium windows and doors are available in 12 standard and 45 designer colors, 8 anodized and 4 radiant metallic colors, with unlimited custom color match aluminum finishes.

Standard Exterior Colors (AAMA 2605 premium paint)



Radiant Metallic Colors (AAMA 2605 premium paint)



Designer Exterior Colors (AAMA 2605 premium paint)



Anodized Exterior Aluminum Finishes

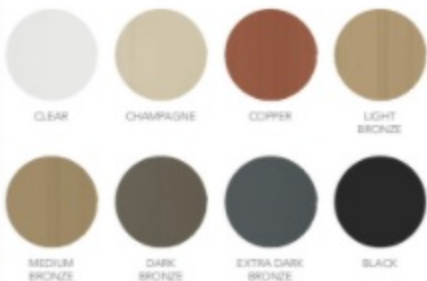

Textured Exterior Aluminum Finishes



Finishes and colors shown may not be actual representations. Please visit an authorized Weather Shield dealer for color samples.

INTERIOR OPTIONS



INTERIOR WOOD OPTIONS

Every home is different. So we give you choices to add your own special touch. Choose the wood grain and color that complement your design. Then add warmth and beauty with our factory finishes. Whether subtle or stunning, you'll find options to make a lasting impression.

Rich Wood Interiors

With eight wood species to choose from, there's sure to be one perfect for your home. For a truly unique look, other wood species are available upon request.



FACTORY FINISHES ON PINE



Durable Factory Finishes

Save time and money with our factory finishing. The wood is stained and sealed on all surfaces to repel moisture and includes two Clear Satin top coats for durability and easy cleaning.

DESIGNER STAINS ON PINE

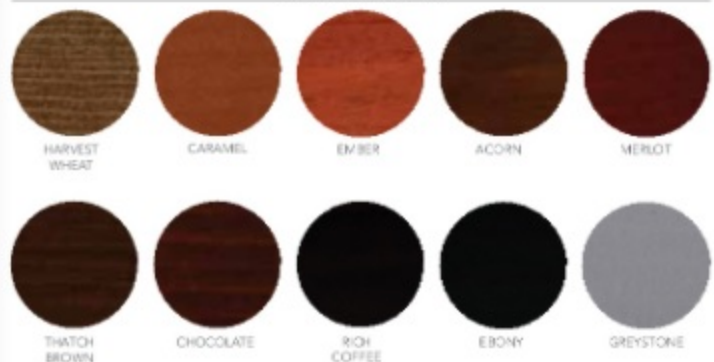

Designer Stains

Explore our new furniture-grade stain offering created in partnership with leading paint and coatings manufacturer Sherwin-Williams®. These new stains provide clean, vivid colors with high pigmentation for excellent clarity and uniformity.

**PROUDLY FINISHED WITH
SHERWIN-WILLIAMS.**

7 Step Process

Our intensive seven step process creates a long-lasting premium finish that will protect and enhance the beauty of your windows and doors for years to come.

7 STEPS TO CREATE A FURNITURE GRADE STAIN

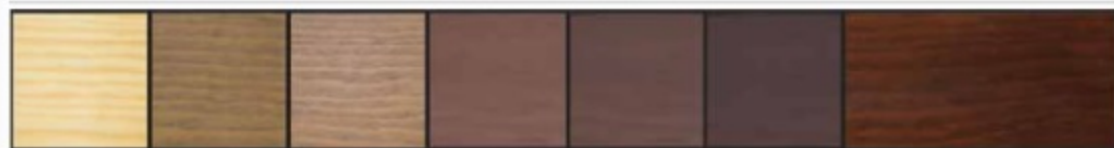

- FINE SANDING**
Prepares wood to accept coatings.
- WASH COAT**
A toned wood conditioner that fills wood pores and creates an even finish.
- STAIN COAT**
Primary color coat, designed to highlight the natural beauty of the wood.
- SEALER COAT**
Builds a smooth surface that locks down the color and provides chemical and moisture resistance.
- BUFFING**
Surfaces are buffed to create an ultra-smooth surface.
- TONER COAT**
This step is used to even out the color and add depth and richness to the final look.
- CLEAR COAT COMPLETED FINISH**
A specially formulated 2K Polyurethane topcoat designed to protect from UV and scratching.

Finishes and colors shown may not be actual representations. Please visit an authorized Weather Shield dealer for color samples. All finishes not available on all wood species. Please visit an authorized Weather Shield dealer for details.

ARCHITECTURALLY INSPIRED, TECHNOLOGICALLY ADVANCED

Our double hung windows represent a one-of-a-kind approach to a popular choice in home design. With the versatility to open from the top or bottom, a breath of fresh air is never out of reach. From robust ventilation to energy efficiency and ease of use, double hung windows are a timeless classic.



Natural Finish
A wood jamb liner covers all mechanical balance systems to create a tailored aesthetic.



Tilt and Release
With concealed tilt release latches, nothing comes between you and the view. Recessed into the lock rail, this design element leaves the sash clear of all visible latch hardware.



Single Handed Ease
The single dual action lock allows the sash to be unlocked and tilted easily with one hand – so you can save your energy for the things that really matter.



High Quality Exteriors

Our aluminum exterior-clad wood products feature commercial-grade premium AAMA 2605 paint that resists fading and chalking. Extruded aluminum resists dents, dings and scratches and is backed by Weather Shield's 20-year limited warranty.

The 3-1/2" bottom rail creates clean lines and ideal architectural proportions.

The Beauty is in the Details

The rigid integral nailing fin makes installation simple and provides more durability than flimsy snap-in or fold-out fins found with other windows.

Butt jointed cadding accurately mimics traditional wood windows for a familiar aesthetic.

DOUBLE HUNG WINDOWS



WINDOWS SHOWN:

Configuration: Double Hung
Interior Finish: White Poly
Features: 5/8" Simulated Divided Lite
Glass: Insulated Low-E with Argon

GRILLE OPTIONS



OUTSTANDING PERFORMANCE, EXCEPTIONAL EFFICIENCY

Selecting the right windows is crucial in determining the style and elegance of your home. We offer only top-of-the-line design and construction, so you can choose among the industry's most innovative options. State-of-the-art windows like these are an investment that pays for itself in a lifetime of reduced costs.

The Perfect Grille

Personalize your home with windows featuring a selection of bar widths and profiles, as well as traditional grille patterns and custom designs. For even greater **creativity and design** flexibility, most grilles can be manufactured from Weather Shield's custom wood interiors collection.

Custom Grille Pattern Options

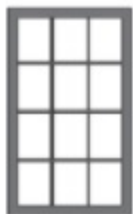

RECTANGULAR



FRAME



FRAME W/ VERTICAL BAR



COTTAGE



COTTAGE T



OREL



SINGLE HORIZONTAL BAR



SIMULATED DOUBLE HUNG

Putty Exterior Aluminum Profile

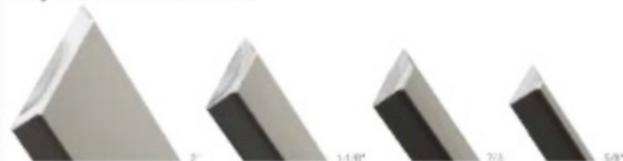

Colonial Interior Wood Profile

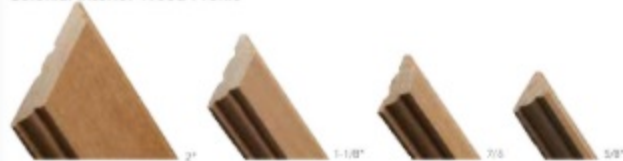

Putty Interior Wood Profile



Square Interior Wood Profile

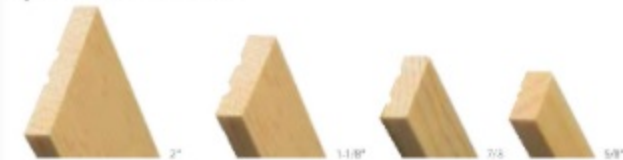

Framed With You in Mind

Featuring a unique **perimeter grille frame design** that rests on the inside of the unit, Weather Shield windows employ a concealed pin system to snap the perimeter grille frame securely into place. These grilles can be easily removed in order to clean the entire interior glass surface.



7/8"



Innovative Design; Classic Appeal

The best of modern energy efficiency meets old-world charm in **Simulated Divided Lite (SDL)** grilles. While mimicking the look of classic single-pane windows, SDL grilles offer exterior and interior grille bars either with or without an aluminum spacer bar — translating to powerful insulation and innovation.

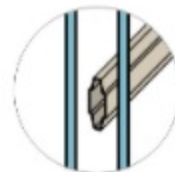

Grilles Between the Glass

Airspace Grilles seal aluminum grille bars in either a sculptured or flat design between two panes of glass. Resulting in a classic aesthetic that is easy to clean and maintain.



1 1/16" SCULPTURED



5/8" FLAT

GLASS OPTIONS



REFLECTIONS OF QUALITY

From specialty glass to high-end glazing, our windows are truly a cut above the rest. Add color and texture options to the glass in your home while enjoying the energy efficiency and quality for which we're known best.

Gold Standard

Weather Shield Premium Series products are certified and labeled according to the highest standards, set by the Window and Door Manufacturers Association (WDMA)/National Fenestration Ratings Council (NFRC) Certification Program. All WDMA/NFRC certified products must pass performance tests conducted by an independent lab for resistance to air leakage, water penetration and wind pressures.

Specialty Glass Options

Add color or texture — or privacy and modesty — to your palette of design options. Special finishes and tint can give a project distinction. Specialty glass includes bronze, gray, rain and obscure.



BRONZE

GRAY

RAIN GLASS

OBSCURE GLASS

SAFIN ETOH

High Quality Glaze

Maximize your windows' energy efficiency with the exclusive Zo-e-shield® glazing system. With powerful layers of Low-E coating, optional EasyCare® surface coating, inert gas-filled insulating airspace, and Real Warm-Edge™ spacers, our glazing options represent the ultimate in energy efficiency for any climate.

Glazing Options

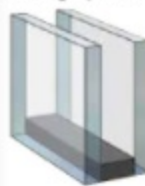

Insulated Low-E

All Climate

- Minimizes the sun's heat and damaging UV rays in warmer months
- Reflects the sun's heat back into room during cooler months

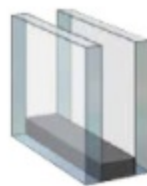

Zo-e-shield 5

Ultimate Solar Control

- Strong resistance to the sun's glaring heat
- Excellent insulating value
- Excellent protection against damaging UV rays
- Maintains great clarity

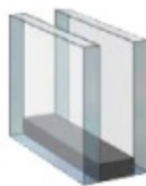

Zo-e-shield 5E

Plus Room Side Low-E

- Combination of two low-e coatings
- Significantly improved energy efficiency
- Complies with northern Energy Star guidelines with Interior Lo-EIR® coating

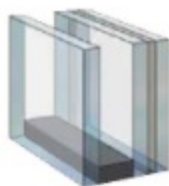

Zo-e-shield 6

Zo-e-shield 5 Plus Laminated Interior

- Best resistance available to the sun's heat
- Minimizes glare and visible light transmittance
- Superior sound control and UV protection

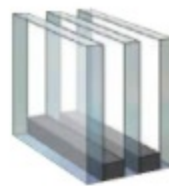

Zo-e-shield 7

Triple Glazed with 5 Coats of Low-E

- Great insulating value
- Controls glare and blocks the sun's heat in warmer months
- Excellent for use in all climate regions

Energy Star

As a proud ENERGY STAR® partner, Weather Shield products are rated, certified and labeled for U-Value and Solar Heat Gain by the National Fenestration Rating Council (NFRC). Many of Weather Shield® windows not only meet, but exceed ENERGY STAR® standards for energy efficient windows and doors. Using ENERGY STAR® windows can also help you save money through various tax rebates and incentives.



Northern

North-Central

South-Central

Southern



The ENERGY STAR® criteria for residential windows and doors are tailored to four Climate Zones. A product's energy efficiency for a given climate is based on its impact on heat gain and loss in cold weather and heat gain in warm weather. Check to see what ENERGY STAR® climate zone you live in utilizing the climate map above.

SCREEN & TRIM OPTIONS



SCREEN AND TRIM OPTIONS

Weather Shield's high-visibility screen options maximize your view and allow more light to flow in. Then add unparalleled design flexibility and customization with our wood interior and aluminum exterior trim options. Available for curved and angle-shaped windows and doors, adding distinctive architectural detail.

Screen Options

Screens allow you to enjoy fresh air flow throughout your home all while keeping out pesky insects. Our High-Visibility, No See-um screen cloth utilizes a much finer mesh that offers more air flow along with better optical clarity. Also available in aluminum, non-glare mesh.

Retractable and Wood Screen

Our **retractable screen** offers unmatched operation with a fully concealed screen channel that maximizes your viewing area. Engineered brake system allows for hands free operation and smooth screen retraction with fully concealed screen components creating a tailored upscale aesthetic.

Hinged from the side, and easily removed for repairs or maintenance, our **wood hinged screen** option welcomes the natural wood character into your home.



NO SEE-UM MESH



ALUMINUM NON-GLARE MESH



WOODHINGED SCREEN

Exterior Trim Options

Our exterior trim accessories allow for a clean and finished exterior look. Available in any of our standard, designer, radiant metallic, or anodized aluminum finishes, these exterior casings add an ideal finishing touch.



ALUMINUM BRONZED



7/8" ALUMINUM BRONZED



3/16" ALUMINUM FLAT CASING



ALUMINUM HISTORICAL BRONZED



1" BALL NOSE



2" BALL NOSE



1" FULL ROUND BALL NOSE

Interior Trim Options

Available in any of our rich wood interiors and finishes, these trims are expertly dried, milled and jointed together reflecting the quality you expect.



WM37 (2-1/4")



WM38 (2-1/4")



WM66 (2-1/4")



WM36 (2-1/4")



WM39 (2-1/2")



WM44 (3-1/4")



WM45 (3-1/4")



WM50K CASING (3-1/2")



FLAT CASING (3-1/2")



ROSETTE (SMALL AND LARGE AVAILABLE)

Commercial Custom Design Solutions

Weather Shield specializes in engineering the perfect solution for your unique window and door challenges. From the replication of historical trim to the creation of custom aluminum extrusions, Weather Shield has the expertise to ensure the success of your next commercial project:

- Custom aluminum extrusions
- Specialized paint and anodized finishing





A1 Interior



A2 Interior

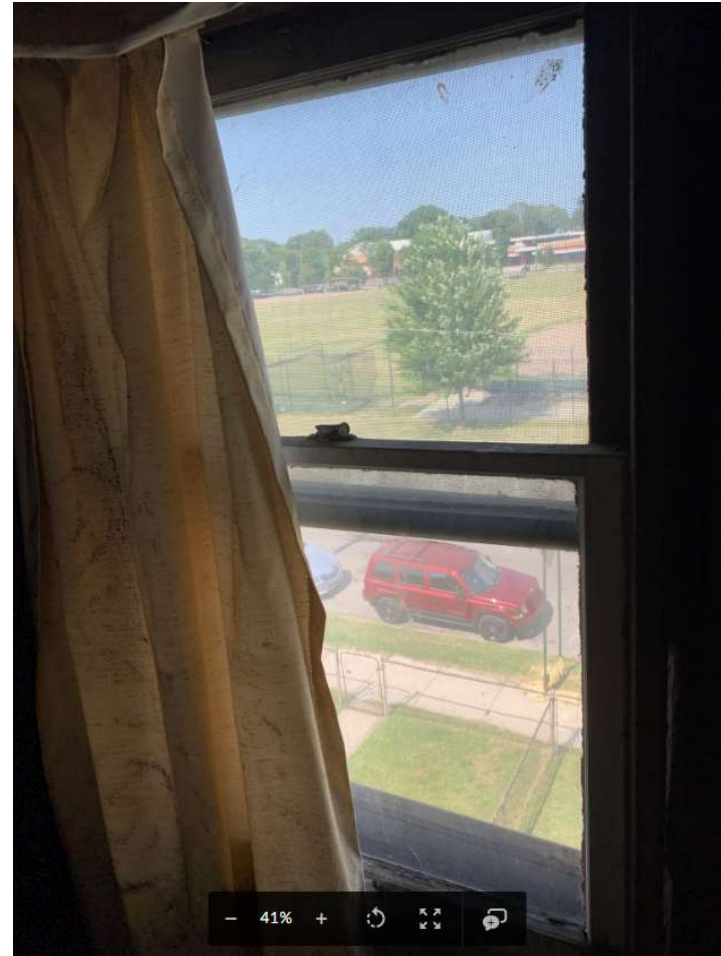

A3 Interior



A4 Interior



A5 Interior



A6 Interior



A7 Interior



A8 Interior



A9 Interior



A10 Interior



A11 Interior



B4 and B5 are wood windows with vinyl cladding outside.



B1 Interior



B2 Interior



B3 Interior



B4 Interior



B5 Interior



Window C1 and C2 are casement windows

Window C3- Vinyl window

Window C4 - wood window with vinyl cladding outside.



C1 & C2 Interior



C3 Interior



C4 Interior



Window D4 - wood window with vinyl cladding outside.



D1 Interior



D2 Interior



D3 Interior



D4 Interior



WEATHER SHIELD.

WINDOWS & DOORS

P.O. Box 309 Medford, WI 54451
weathershield.com

QUOTE

Printed: 08/05/2020 05:05 PM
Project Date: 08/05/2020

Quote #: 2389067
Quote Date: 08/05/2020
WSOneSource 1.0

Sold To: 59377
DMC GROUP
13500 FOLEY ST
DETROIT, MI 48227

Ship To: 59377
DMC GROUP

Delivery Instructions:

Deliver To:

LINE #	QUANTITY	ATTRIBUTES	UNIT	EXTENDED
--------	----------	------------	------	----------

1 1 P.O.:
Location: FRONT FOYER
Job: 1035 CLARK

A8

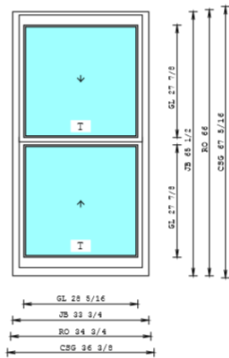

Weather Shield Double Hung Tilt Rectangle 610 1 Wide
Complete Unit
----- Mfg Date 8/8/2008 to Present
----- Frame Style Double Hung
See weathershield.com for PG/DP information
Sizing Method Jb to Jb/Frame Size - Even
----- R/O Size 34 3/4" X 66"
----- Jamb Size 33 3/4" X 65 1/2"
Venting R/O - Top 33" Venting R/O - Btm 33"
----- Glass Size - Top 28 5/16" X 27 7/8" - Bottom 28 5/16" X 27 7/8"
Operating Code - Operating
Poly - - White
----- Exterior Panel/Sash Color White
- Factory Applied
----- Standard Sillnose -
----- 5 1/2" Installation Clips - Factory Applied
4 9/16" Jamb Depth -
Pine - Prefinished White
----- White Vinyl Jamb Liner
Insulated Low E
----- W/Out Neat Clean Glass
Glazing Bead Type - Colonial
----- W/Out Protective Film
----- Tempered All Sash
----- Silver Spacer
----- W/Inert Airspace Gas
1 Lite -
White - Double Locks -
----- No Jamb Jack Screws
W/Full Screen - White - NO-SEE-UM Mesh - Shipped Loose
Standard Unit
No Field Prepping

(Viewed from Exterior)

Rough Opening 34-3/4" x 66"
Overall Jamb 33-3/4" x 65-1/2"

Lead Time: 5 Weeks

WEATHER SHIELD.

WINDOWS & DOORS

P.O. Box 309 Medford, WI 54451
weathershield.com

QUOTE

Printed: 08/05/2020 05:05 PM
Project Date: 08/05/2020

Quote #: 2389067
Quote Date: 08/05/2020
WSOneSource 1.0

LINE #	QUANTITY	ATTRIBUTES	UNIT	EXTENDED
--------	----------	------------	------	----------

2 2 P.O.:
Location: LIVING RM
Job: 1035 CLARK

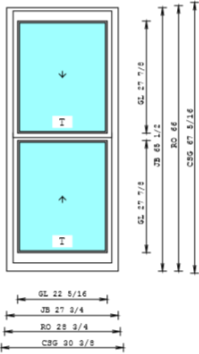

Weather Shield Double Hung Tilt Rectangle 610 1 Wide Complete Unit
---- Mfg Date 8/8/2008 to Present
---- Frame Style Double Hung
See weathershield.com for PG/DP information
Sizing Method Jb to Jb/Frame Size - Even
---- R/O Size 28 3/4" X 66"
---- Jamb Size 27 3/4" X 65 1/2"
Venting R/O - Top 33" Venting R/O - Btm 33"
---- Glass Size - Top 22 5/16" X 27 7/8" - Bottom 22 5/16" X 27 7/8"
Operating Code - Operating
Poly - - White
---- Exterior Panel/Sash Color White
- Factory Applied
---- Standard Sillnose -
---- 5 1/2" Installation Clips - Factory Applied
4 9/16" Jamb Depth -
Pine - Prefinished White
---- White Vinyl Jamb Liner
Insulated Low E
---- W/Out Neat Clean Glass
Glazing Bead Type - Colonial
---- W/Out Protective Film
---- Tempered All Sash
---- Silver Spacer
---- W/Inert Airspace Gas
1 Lite -
White - Double Locks -
---- No Jamb Jack Screws
W/Full Screen - White - NO-SEE-UM Mesh - Shipped Loose
Standard Unit
No Field Prepping

A9 & A11

(Viewed from Exterior)

Rough Opening 28-3/4" x 66"
Overall Jamb 27-3/4" x 65-1/2"

Lead Time: 5 Weeks

WEATHER SHIELD.

WINDOWS & DOORS

P.O. Box 309 Medford, WI 54451
weathershield.com

QUOTE

Printed: 09/23/2020 08:43 AM
Project Date: 09/23/2020

Quote #: 2389067
Quote Date: 08/05/2020
WSOneSource 1.0

LINE #	QUANTITY	ATTRIBUTES	UNIT	EXTENDED
--------	----------	------------	------	----------

3 1 P.O.:
Location: LIVING RM
Job: 1035 CLARK

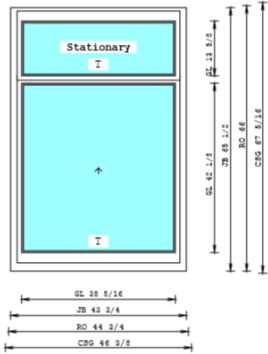

Weather Shield Double Hung Tilt Rectangle 610 1 Wide Complete Unit
 ----- Mfg Date 8/8/2008 to Present
 ----- Frame Style Double Hung
 See weathershield.com for PG/DP information
 Sizing Method Jb to Jb/Frame Size - Custom Cottage Venting
 ----- R/O Size 44 3/4" X 66"
 ----- Jamb Size 43 3/4" X 65 1/2"
 ----- Venting Jb to Jb - Top 18 1/2" Venting Jb to Jb - Btm 47" Venting R/O - Top 18 3/4" Venting R/
 ----- Glass Size - Top 38 5/16" X 13 5/8" - Bottom 38 5/16" X 42 1/8"
 Operating Code - Top Sash Stationary
 Poly - - White
 ----- Exterior Panel/Sash Color White
 - Factory Applied
 ----- Standard Sillnose -
 ----- 5 1/2" Installation Clips - Factory Applied
 4 9/16" Jamb Depth -
 Pine - Prefinished White
 ----- White Vinyl Jamb Liner
 Insulated Low E
 ----- W/Out Neat Clean Glass
 Glazing Bead Type - Colonial
 ----- W/Out Protective Film
 ----- Tempered All Sash
 ----- Silver Spacer
 ----- W/Inert Airspace Gas
 1 Lite -
 White - Double Locks -
 ----- No Jamb Jack Screws
 No Screen -
 Standard Unit
 No Field Prepping

A10

(Viewed from Exterior)

Rough Opening 44-3/4" x 66"
Overall Jamb 43-3/4" x 65-1/2"

Lead Time: 5 Weeks

WEATHER SHIELD.

WINDOWS & DOORS

P.O. Box 309 Medford, WI 54451
weathershield.com

QUOTE

Printed: 08/05/2020 05:05 PM
Project Date: 08/05/2020

Quote #: 2389067
Quote Date: 08/05/2020
WSOneSource 1.0

LINE #	QUANTITY	ATTRIBUTES	UNIT	EXTENDED
--------	----------	------------	------	----------

4 1 P.O.:
Location: DINING RM
Job: 1035 CLARK

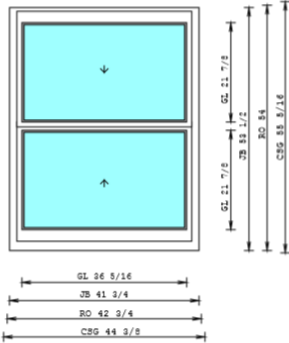

Weather Shield Double Hung Tilt Rectangle 610 1 Wide Complete Unit
 ----- Mfg Date 8/8/2008 to Present
 ----- Frame Style Double Hung
 See weathershield.com for PG/DP information
 Sizing Method Jb to Jb/Frame Size - Even
 ----- R/O Size 42 3/4" X 54"
 ----- Jamb Size 41 3/4" X 53 1/2"
 Venting R/O - Top 27" Venting R/O - Btm 27"
 ----- Glass Size - Top 36 5/16" X 21 7/8" - Bottom 36 5/16" X 21 7/8"
 Operating Code - Operating
 Poly - - White
 ----- Exterior Panel/Sash Color White
 - Factory Applied
 ----- Standard Sillnose -
 ----- 5 1/2" Installation Clips - Factory Applied
 4 9/16" Jamb Depth -
 Pine - Prefinished White
 ----- White Vinyl Jamb Liner
 Insulated Low E
 ----- W/Out Neat Clean Glass
 Glazing Bead Type - Colonial
 ----- W/Out Protective Film
 ----- Silver Spacer
 ----- W/Inert Airspace Gas
 1 Lite -
 White - Double Locks -
 ----- No Jamb Jack Screws
 W/Full Screen - White - NO-SEE-UM Mesh - Shipped Loose
 Standard Unit
 No Field Prepping

D3

(Viewed from Exterior)

Rough Opening 42-3/4" x 54"
Overall Jamb 41-3/4" x 53-1/2"

Lead Time: 5 Weeks

WEATHER SHIELD.

WINDOWS & DOORS

P.O. Box 309 Medford, WI 54451
weathershield.com

QUOTE

Printed: 08/05/2020 05:05 PM
Project Date: 08/05/2020

Quote #: 2389067
Quote Date: 08/05/2020
WSOneSource 1.0

LINE #	QUANTITY	ATTRIBUTES	UNIT	EXTENDED
--------	----------	------------	------	----------

5 2 P.O.:
Location: BEDROOM
Job: 1035 CLARK

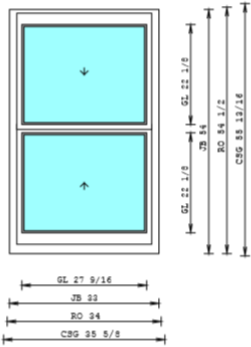

Weather Shield Double Hung Tilt Rectangle 610 1 Wide
Complete Unit
---- Mfg Date 8/8/2008 to Present
---- Frame Style Double Hung
See weathershield.com for PG/DP information
Sizing Method Jb to Jb/Frame Size - Even
---- R/O Size 34" X 54 1/2"
---- Jamb Size 33" X 54"
Venting R/O - Top 27 1/4" Venting R/O - Btm 27 1/4"
---- Glass Size - Top 27 9/16" X 22 1/8" - Bottom 27 9/16" X 22 1/8"
Operating Code - Operating
Poly - - White
---- Exterior Panel/Sash Color White
- Factory Applied
---- Standard Sillnose -
---- 5 1/2" Installation Clips - Factory Applied
4 9/16" Jamb Depth -
Pine - Prefinished White
---- White Vinyl Jamb Liner
Insulated Low E
---- W/Out Neat Clean Glass
Glazing Bead Type - Colonial
---- W/Out Protective Film
---- Silver Spacer
---- W/Inert Airspace Gas
1 Lite -
White - Double Locks -
---- No Jamb Jack Screws
W/Full Screen - White - NO-SEE-UM Mesh - Shipped Loose
Standard Unit
No Field Prepping

D4 & C4

(Viewed from Exterior)

Rough Opening 34" x 54-1/2"
Overall Jamb 33" x 54"

Lead Time: 5 Weeks

WEATHER SHIELD.

WINDOWS & DOORS

P.O. Box 309 Medford, WI 54451
weathershield.com

QUOTE

Printed: 08/05/2020 05:05 PM
Project Date: 08/05/2020

Quote #: 2389067
Quote Date: 08/05/2020
WSOneSource 1.0

LINE #	QUANTITY	ATTRIBUTES	UNIT	EXTENDED
--------	----------	------------	------	----------

6 1 P.O.:
Location: BATHROOM
Job: 1035 CLARK

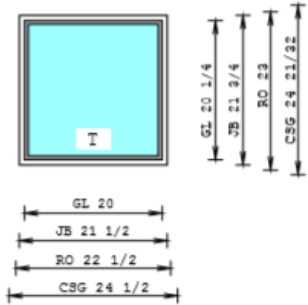

Weather Shield Direct Set Rectangle 630 Direct Set 1 Wide Complete Unit
 ----- Mfg Date 12/1/1988 to Present
 ----- Frame Style Double Hung
 See weathershield.com for PG/DP information
 Sizing Method Jb to Jb/Frame Size
 ----- R/O Size 22 1/2" X 23"
 ----- Jamb Size 21 1/2" X 21 3/4"
 ----- Glass Size 20" X 20 1/4"
 Primed - - Primed
 - Factory Applied
 ----- Standard Subsill -
 ----- 5 1/2" Installation Clips - Factory Applied
 4 9/16" Jamb Depth -
 Pine - Prefinished White
 Insulated Low E
 ----- W/Out Neat Clean Glass
 Glazing Bead Type - Colonial
 ----- W/Out Protective Film
 ----- Obscure
 ----- Tempered Glass
 ----- Silver Spacer
 ----- W/Inert Airspace Gas
 1 Lite -
 Standard Unit
 No Field Prepping

Interior window

(Viewed from Exterior)

Rough Opening 22-1/2" x 23"
Overall Jamb 21-1/2" x 21-3/4"

Lead Time: 4 Weeks

WEATHER SHIELD.

WINDOWS & DOORS

P.O. Box 309 Medford, WI 54451
weathershield.com

QUOTE

Printed: 08/05/2020 05:05 PM
Project Date: 08/05/2020

Quote #: 2389067
Quote Date: 08/05/2020
WSOneSource 1.0

LINE #	QUANTITY	ATTRIBUTES	UNIT	EXTENDED
--------	----------	------------	------	----------

7 1 P.O.:
Location: KITCHEN
Job: 1035 CLARK

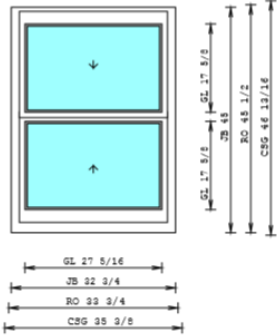

Weather Shield Double Hung Tilt Rectangle 610 1 Wide Complete Unit
 ----- Mfg Date 8/8/2008 to Present
 ----- Frame Style Double Hung
 See weathershield.com for PG/DP information
 Sizing Method Jb to Jb/Frame Size - Even
 ----- R/O Size 33 3/4" X 45 1/2"
 ----- Jamb Size 32 3/4" X 45"
 Venting R/O - Top 22 3/4" Venting R/O - Btm 22 3/4"
 ----- Glass Size - Top 27 5/16" X 17 5/8" - Bottom 27 5/16" X 17 5/8"
 Operating Code - Operating
 Poly - - White
 ----- Exterior Panel/Sash Color White
 - Factory Applied
 ----- Standard Sillnose -
 ----- 5 1/2" Installation Clips - Factory Applied
 4 9/16" Jamb Depth -
 Pine - Prefinished White
 ----- White Vinyl Jamb Liner
 Insulated Low E
 ----- W/Out Neat Clean Glass
 Glazing Bead Type - Colonial
 ----- W/Out Protective Film
 ----- Silver Spacer
 ----- W/Inert Airspace Gas
 1 Lite -
 White - Double Locks -
 ----- No Jamb Jack Screws
 W/Full Screen - White - NO-SEE-UM Mesh - Shipped Loose
 Standard Unit
 No Field Prepping

B 5

(Viewed from Exterior)

Rough Opening 33-3/4" x 45-1/2"
Overall Jamb 32-3/4" x 45"

Lead Time: 5 Weeks

WEATHER SHIELD.

WINDOWS & DOORS

P.O. Box 309 Medford, WI 54451
weathershield.com

QUOTE

Printed: 08/05/2020 05:05 PM
Project Date: 08/05/2020

Quote #: 2389067
Quote Date: 08/05/2020
WSOneSource 1.0

LINE #	QUANTITY	ATTRIBUTES	UNIT	EXTENDED
--------	----------	------------	------	----------

8 1 P.O.:
Location: KITCHEN
Job: 1035 CLARK

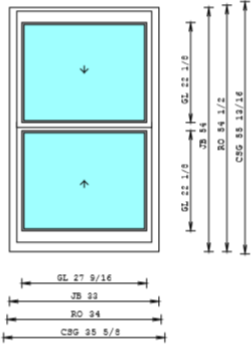

Weather Shield Double Hung Tilt Rectangle 610 1 Wide
Complete Unit
---- Mfg Date 8/8/2008 to Present
---- Frame Style Double Hung
See weathershield.com for PG/DP information
Sizing Method Jb to Jb/Frame Size - Even
---- R/O Size 34" X 54 1/2"
---- Jamb Size 33" X 54"
Venting R/O - Top 27 1/4" Venting R/O - Btm 27 1/4"
---- Glass Size - Top 27 9/16" X 22 1/8" - Bottom 27 9/16" X 22 1/8"
Operating Code - Operating
Poly - - White
---- Exterior Panel/Sash Color White
- Factory Applied
---- Standard Sillnose -
---- 5 1/2" Installation Clips - Factory Applied
4 9/16" Jamb Depth -
Pine - Prefinished White
---- White Vinyl Jamb Liner
Insulated Low E
---- W/Out Neat Clean Glass
Glazing Bead Type - Colonial
---- W/Out Protective Film
---- Silver Spacer
---- W/Inert Airspace Gas
1 Lite -
White - Double Locks -
---- No Jamb Jack Screws
W/Full Screen - White - NO-SEE-UM Mesh - Shipped Loose
Standard Unit
No Field Prepping

B 4

(Viewed from Exterior)

Rough Opening 34" x 54-1/2"
Overall Jamb 33" x 54"

Lead Time: 5 Weeks

WEATHER SHIELD.

WINDOWS & DOORS

P.O. Box 309 Medford, WI 54451
weathershield.com

QUOTE

Printed: 09/23/2020 08:43 AM
Project Date: 09/23/2020

Quote #: 2389067
Quote Date: 08/05/2020
WSOneSource 1.0

LINE #	QUANTITY	ATTRIBUTES	UNIT	EXTENDED
--------	----------	------------	------	----------

9 1 P.O.:
Location: STAIRCASE
Job: 1035 CLARK

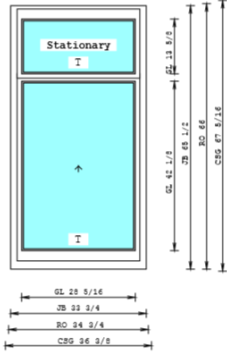

Weather Shield Double Hung Tilt Rectangle 610 1 Wide Complete Unit
 ----- Mfg Date 8/8/2008 to Present
 ----- Frame Style Double Hung
 See weathershield.com for PG/DP information
 Sizing Method Jb to Jb/Frame Size - Custom Cottage Venting
 ----- R/O Size 34 3/4" X 66"
 ----- Jamb Size 33 3/4" X 65 1/2"
 ----- Venting Jb to Jb - Top 18 1/2" Venting Jb to Jb - Btm 47" Venting R/O - Top 18 3/4" Venting R/
 ----- Glass Size - Top 28 5/16" X 13 5/8" - Bottom 28 5/16" X 42 1/8"
 Operating Code - Top Sash Stationary
 Poly - - White
 ----- Exterior Panel/Sash Color White
 - Factory Applied
 ----- Standard Sillnose -
 ----- 5 1/2" Installation Clips - Factory Applied
 4 9/16" Jamb Depth -
 Pine - Prefinished White
 ----- White Vinyl Jamb Liner
 Insulated Low E
 ----- W/Out Neat Clean Glass
 Glazing Bead Type - Colonial
 ----- W/Out Protective Film
 ----- Tempered All Sash
 ----- Silver Spacer
 ----- W/Inert Airspace Gas
 1 Lite -
 White - Double Locks -
 ----- No Jamb Jack Screws
 W/Full Screen - White - NO-SEE-UM Mesh - Shipped Loose
 Standard Unit
 No Field Prepping

B3

(Viewed from Exterior)

Rough Opening 34-3/4" x 66"
Overall Jamb 33-3/4" x 65-1/2"

Lead Time: 5 Weeks

WEATHER SHIELD.

WINDOWS & DOORS

P.O. Box 309 Medford, WI 54451
weathershield.com

QUOTE

Printed: 08/05/2020 05:05 PM
Project Date: 08/05/2020

Quote #: 2389067
Quote Date: 08/05/2020
WSOneSource 1.0

LINE #	QUANTITY	ATTRIBUTES	UNIT	EXTENDED
--------	----------	------------	------	----------

10 2 P.O.:
Location: BEDROOM
Job: 1035 CLARK

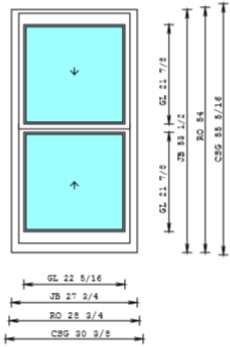

Weather Shield Double Hung Tilt Rectangle 610 1 Wide Complete Unit
 ----- Mfg Date 8/8/2008 to Present
 ----- Frame Style Double Hung
 See weathershield.com for PG/DP information
 Sizing Method Jb to Jb/Frame Size - Even
 ----- R/O Size 28 3/4" X 54"
 ----- Jamb Size 27 3/4" X 53 1/2"
 Venting R/O - Top 27" Venting R/O - Btm 27"
 ----- Glass Size - Top 22 5/16" X 21 7/8" - Bottom 22 5/16" X 21 7/8"
 Operating Code - Operating
 Poly - - White
 ----- Exterior Panel/Sash Color White
 - Factory Applied
 ----- Standard Sillnose -
 ----- 5 1/2" Installation Clips - Factory Applied
 4 9/16" Jamb Depth -
 Pine - Prefinished White
 ----- White Vinyl Jamb Liner
 Insulated Low E
 ----- W/Out Neat Clean Glass
 Glazing Bead Type - Colonial
 ----- W/Out Protective Film
 ----- Silver Spacer
 ----- W/Inert Airspace Gas
 1 Lite -
 White - Double Locks -
 ----- No Jamb Jack Screws
 W/Full Screen - White - NO-SEE-UM Mesh - Shipped Loose
 Standard Unit
 No Field Prepping

A3 & A4

(Viewed from Exterior)

Rough Opening 28-3/4" x 54"
Overall Jamb 27-3/4" x 53-1/2"

Lead Time: 5 Weeks

WEATHER SHIELD.

WINDOWS & DOORS

P.O. Box 309 Medford, WI 54451
weathershield.com

QUOTE

Printed: 08/05/2020 05:05 PM
Project Date: 08/05/2020

Quote #: 2389067
Quote Date: 08/05/2020
WSOneSource 1.0

LINE #	QUANTITY	ATTRIBUTES	UNIT	EXTENDED
--------	----------	------------	------	----------

11 2 P.O.:
Location: BEDROOM
Job: 1035 CLARK

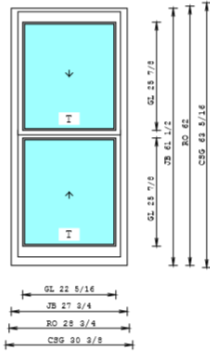

Weather Shield Double Hung Tilt Rectangle 610 1 Wide
Complete Unit
---- Mfg Date 8/8/2008 to Present
---- Frame Style Double Hung
See weathershield.com for PG/DP information
Sizing Method Jb to Jb/Frame Size - Even
---- R/O Size 28 3/4" X 62"
---- Jamb Size 27 3/4" X 61 1/2"
Venting R/O - Top 31" Venting R/O - Btm 31"
---- Glass Size - Top 22 5/16" X 25 7/8" - Bottom 22 5/16" X 25 7/8"
Operating Code - Operating
Poly - - White
---- Exterior Panel/Sash Color White
- Factory Applied
---- Standard Sillnose -
---- 5 1/2" Installation Clips - Factory Applied
4 9/16" Jamb Depth -
Pine - Prefinished White
---- White Vinyl Jamb Liner
Insulated Low E
---- W/Out Neat Clean Glass
Glazing Bead Type - Colonial
---- W/Out Protective Film
---- Tempered All Sash
---- Silver Spacer
---- W/Inert Airspace Gas
1 Lite -
White - Double Locks -
---- No Jamb Jack Screws
W/Full Screen - White - NO-SEE-UM Mesh - Shipped Loose
Standard Unit
No Field Prepping

A5 & A7

(Viewed from Exterior)

Rough Opening 28-3/4" x 62"
Overall Jamb 27-3/4" x 61-1/2"

Lead Time: 5 Weeks

WEATHER SHIELD.

WINDOWS & DOORS

P.O. Box 309 Medford, WI 54451
weathershield.com

QUOTE

Printed: 08/05/2020 05:05 PM
Project Date: 08/05/2020

Quote #: 2389067
Quote Date: 08/05/2020
WSOneSource 1.0

LINE #	QUANTITY	ATTRIBUTES	UNIT	EXTENDED
--------	----------	------------	------	----------

12 1 P.O.:
Location: BEDROOM
Job: 1035 CLARK

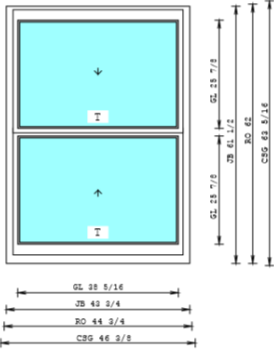

Weather Shield Double Hung Tilt Rectangle 610 1 Wide
Complete Unit
---- Mfg Date 8/8/2008 to Present
---- Frame Style Double Hung
See weathershield.com for PG/DP information
Sizing Method Jb to Jb/Frame Size - Even
---- R/O Size 44 3/4" X 62"
---- Jamb Size 43 3/4" X 61 1/2"
Venting R/O - Top 31" Venting R/O - Btm 31"
---- Glass Size - Top 38 5/16" X 25 7/8" - Bottom 38 5/16" X 25 7/8"
Operating Code - Operating
Poly - - White
---- Exterior Panel/Sash Color White
- Factory Applied
---- Standard Sillnose -
---- 5 1/2" Installation Clips - Factory Applied
4 9/16" Jamb Depth -
Pine - Prefinished White
---- White Vinyl Jamb Liner
Insulated Low E
---- W/Out Neat Clean Glass
Glazing Bead Type - Colonial
---- W/Out Protective Film
---- Tempered All Sash
---- Silver Spacer
---- W/Inert Airspace Gas
1 Lite -
White - Double Locks -
---- No Jamb Jack Screws
W/Full Screen - White - NO-SEE-UM Mesh - Shipped Loose
Standard Unit
No Field Prepping

A6

(Viewed from Exterior)

Rough Opening 44-3/4" x 62"
Overall Jamb 43-3/4" x 61-1/2"

Lead Time: 5 Weeks

WEATHER SHIELD.

WINDOWS & DOORS

P.O. Box 309 Medford, WI 54451
weathershield.com

QUOTE

Printed: 08/05/2020 05:05 PM
Project Date: 08/05/2020

Quote #: 2389067
Quote Date: 08/05/2020
WSOneSource 1.0

LINE #	QUANTITY	ATTRIBUTES	UNIT	EXTENDED
--------	----------	------------	------	----------

13 1 P.O.:
Location: BEDROOM
Job: 1035 CLARK

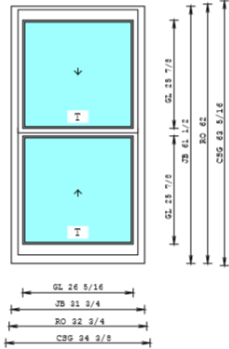

Weather Shield Double Hung Tilt Rectangle 610 1 Wide Complete Unit
 ----- Mfg Date 8/8/2008 to Present
 ----- Frame Style Double Hung
 See weathershield.com for PG/DP information
 Sizing Method Jb to Jb/Frame Size - Even
 ----- R/O Size 32 3/4" X 62"
 ----- Jamb Size 31 3/4" X 61 1/2"
 Venting R/O - Top 31" Venting R/O - Btm 31"
 ----- Glass Size - Top 26 5/16" X 25 7/8" - Bottom 26 5/16" X 25 7/8"
 Operating Code - Operating
 Poly - - White
 ----- Exterior Panel/Sash Color White
 - Factory Applied
 ----- Standard Sillnose -
 ----- 5 1/2" Installation Clips - Factory Applied
 4 9/16" Jamb Depth -
 Pine - Prefinished White
 ----- White Vinyl Jamb Liner
 Insulated Low E
 ----- W/Out Neat Clean Glass
 Glazing Bead Type - Colonial
 ----- W/Out Protective Film
 ----- Tempered All Sash
 ----- Silver Spacer
 ----- W/Inert Airspace Gas
 1 Lite -
 White - Double Locks -
 ----- No Jamb Jack Screws
 W/Full Screen - White - NO-SEE-UM Mesh - Shipped Loose
 Standard Unit
 No Field Prepping

D2

(Viewed from Exterior)

Rough Opening 32-3/4" x 62"
Overall Jamb 31-3/4" x 61-1/2"

Lead Time: 5 Weeks

WEATHER SHIELD.

WINDOWS & DOORS

P.O. Box 309 Medford, WI 54451
weathershield.com

QUOTE

Printed: 08/05/2020 05:05 PM
Project Date: 08/05/2020

Quote #: 2389067
Quote Date: 08/05/2020
WSOneSource 1.0

LINE #	QUANTITY	ATTRIBUTES	UNIT	EXTENDED
--------	----------	------------	------	----------

14 1 P.O.:
Location: BATHROOM
Job: 1035 CLARK

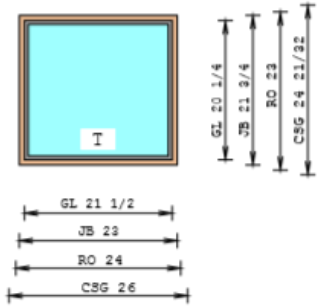

Weather Shield Direct Set Rectangle 630 Direct Set 1 Wide
Complete Unit
---- Mfg Date 12/1/1988 to Present
---- Frame Style Double Hung
See weathershield.com for PG/DP information
Sizing Method Jb to Jb/Frame Size
---- R/O Size 24" X 23"
---- Jamb Size 23" X 21 3/4"
---- Glass Size 21 1/2" X 20 1/4"
No Prime/No Fingerjoint - - No Prime/No Fingerjoint
- Factory Applied
---- Standard Subsill -
---- 5 1/2" Installation Clips - Factory Applied
4 9/16" Jamb Depth -
Pine - Prefinished White
Insulated Low E
---- W/Out Neat Clean Glass
Glazing Bead Type - Colonial
---- W/Out Protective Film
---- Obscure
---- Tempered Glass
---- Silver Spacer
---- W/Inert Airspace Gas
1 Lite -
Standard Unit
No Field Prepping

C3

(Viewed from Exterior)

Rough Opening 24" x 23"
Overall Jamb 23" x 21-3/4"

Lead Time: 4 Weeks

WEATHER SHIELD.

WINDOWS & DOORS

P.O. Box 309 Medford, WI 54451
weathershield.com

QUOTE

Printed: 08/05/2020 05:05 PM
Project Date: 08/05/2020

Quote #: 2389067
Quote Date: 08/05/2020
WSOneSource 1.0

LINE #	QUANTITY	ATTRIBUTES	UNIT	EXTENDED
--------	----------	------------	------	----------

15 1 P.O.:
Location: BEDROOM
Job: 1035 CLARK

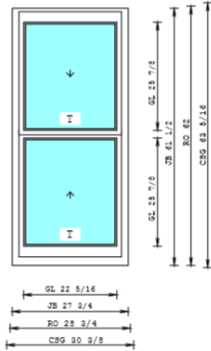

Weather Shield Double Hung Tilt Rectangle 610 1 Wide Complete Unit
 ----- Mfg Date 8/8/2008 to Present
 ----- Frame Style Double Hung
 See weathershield.com for PG/DP information
 Sizing Method Jb to Jb/Frame Size - Even
 ----- R/O Size 28 3/4" X 62"
 ----- Jamb Size 27 3/4" X 61 1/2"
 Venting R/O - Top 31" Venting R/O - Btm 31"
 ----- Glass Size - Top 22 5/16" X 25 7/8" - Bottom 22 5/16" X 25 7/8"
 Operating Code - Operating
 Poly - - White
 ----- Exterior Panel/Sash Color White
 - Factory Applied
 ----- Standard Sillnose -
 ----- 5 1/2" Installation Clips - Factory Applied
 4 9/16" Jamb Depth -
 Pine - Prefinished White
 ----- White Vinyl Jamb Liner
 Insulated Low E
 ----- W/Out Neat Clean Glass
 Glazing Bead Type - Colonial
 ----- W/Out Protective Film
 ----- Tempered All Sash
 ----- Silver Spacer
 ----- W/Inert Airspace Gas
 1 Lite -
 White - Double Locks -
 ----- No Jamb Jack Screws
 W/Full Screen - White - NO-SEE-UM Mesh - Shipped Loose
 Standard Unit
 No Field Prepping

B2

(Viewed from Exterior)

Rough Opening 28-3/4" x 62"
Overall Jamb 27-3/4" x 61-1/2"

Lead Time: 5 Weeks

WEATHER SHIELD.

WINDOWS & DOORS

P.O. Box 309 Medford, WI 54451
weathershield.com

QUOTE

Printed: 08/05/2020 05:05 PM
Project Date: 08/05/2020

Quote #: 2389067
Quote Date: 08/05/2020
WSOneSource 1.0

LINE #	QUANTITY	ATTRIBUTES	UNIT	EXTENDED
--------	----------	------------	------	----------

16 1 P.O.:
Location: ATTIC
Job: 1035 CLARK

A1

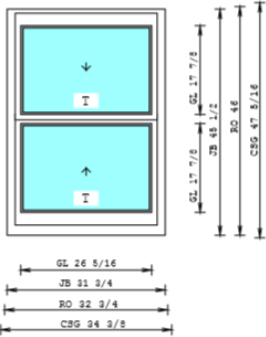

Weather Shield Double Hung Tilt Rectangle 610 1 Wide Complete Unit
 ----- Mfg Date 8/8/2008 to Present
 ----- Frame Style Double Hung
 See weathershield.com for PG/DP information
 Sizing Method Jb to Jb/Frame Size - Even
 ----- R/O Size 32 3/4" X 46"
 ----- Jamb Size 31 3/4" X 45 1/2"
 Venting R/O - Top 23" Venting R/O - Btm 23"
 ----- Glass Size - Top 26 5/16" X 17 7/8" - Bottom 26 5/16" X 17 7/8"
 Operating Code - Operating
 Poly - - White
 ----- Exterior Panel/Sash Color White
 - Factory Applied
 ----- Standard Sillnose -
 ----- 5 1/2" Installation Clips - Factory Applied
 4 9/16" Jamb Depth -
 Pine - Prefinished White
 ----- White Vinyl Jamb Liner
 Insulated Low E
 ----- W/Out Neat Clean Glass
 Glazing Bead Type - Colonial
 ----- W/Out Protective Film
 ----- Tempered All Sash
 ----- Silver Spacer
 ----- W/Inert Airspace Gas
 1 Lite -
 White - Double Locks -
 ----- No Jamb Jack Screws
 W/Full Screen - White - NO-SEE-UM Mesh - Shipped Loose
 Standard Unit
 No Field Prepping

(Viewed from Exterior)

Rough Opening 32-3/4" x 46"
Overall Jamb 31-3/4" x 45-1/2"

Lead Time: 5 Weeks

WEATHER SHIELD.

WINDOWS & DOORS

P.O. Box 309 Medford, WI 54451
weathershield.com

QUOTE

Printed: 09/24/2020 01:15 PM
Project Date: 09/23/2020

Quote #: 2389067
Quote Date: 08/05/2020
WSOneSource 1.0

LINE #	QUANTITY	ATTRIBUTES	UNIT	EXTENDED
--------	----------	------------	------	----------

17 2 P.O.:
Location: ATTIC
Job: 1035 CLARK

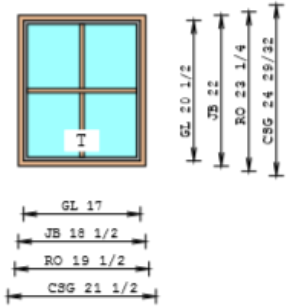

Weather Shield Direct Set Rectangle 630 Direct Set 1 Wide Complete Unit
 ----- Mfg Date 12/1/1988 to Present
 ----- Frame Style Double Hung
 See weathershield.com for PG/DP information
 Sizing Method Jb to Jb/Frame Size
 ----- R/O Size 19 1/2" X 23 1/4"
 ----- Jamb Size 18 1/2" X 22"
 ----- Glass Size 17" X 20 1/2"
 No Prime/No Fingerjoint - - No Prime/No Fingerjoint
 - Factory Applied
 ----- Standard Subsill -
 ----- 5 1/2" Installation Clips - Factory Applied
 4 9/16" Jamb Depth -
 Pine - Prefinished White
 Insulated Low E
 ----- W/Out Neat Clean Glass
 Glazing Bead Type - Colonial
 ----- W/Out Protective Film
 ----- Tempered Glass
 ----- Silver Spacer
 ----- W/Inert Airspace Gas
 5/8" - Pine - Wood Grille - Rectangular - Factory Applied
 ----- Prefinished White -
 ----- 2 W 2 H /
 Standard Unit
 No Field Prepping

C1 & C2

(Viewed from Exterior)

Rough Opening 19-1/2" x 23-1/4"
Overall Jamb 18-1/2" x 22"

Lead Time: 4 Weeks

WEATHER SHIELD.

WINDOWS & DOORS

P.O. Box 309 Medford, WI 54451
weathershield.com

QUOTE

Printed: 08/05/2020 05:05 PM
Project Date: 08/05/2020

Quote #: 2389067
Quote Date: 08/05/2020
WSOneSource 1.0

LINE #	QUANTITY	ATTRIBUTES	UNIT	EXTENDED
--------	----------	------------	------	----------

18 1 P.O.:
Location: ATTIC
Job: 1035 CLARK

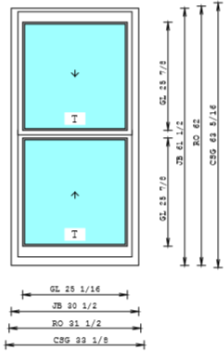

Weather Shield Double Hung Tilt Rectangle 610 1 Wide
Complete Unit
---- Mfg Date 8/8/2008 to Present
---- Frame Style Double Hung
See weathershield.com for PG/DP information
Sizing Method Jb to Jb/Frame Size - Even
---- R/O Size 31 1/2" X 62"
---- Jamb Size 30 1/2" X 61 1/2"
Venting R/O - Top 31" Venting R/O - Btm 31"
---- Glass Size - Top 25 1/16" X 25 7/8" - Bottom 25 1/16" X 25 7/8"
Operating Code - Operating
Poly - - White
---- Exterior Panel/Sash Color White
- Factory Applied
---- Standard Sillnose -
---- 5 1/2" Installation Clips - Factory Applied
4 9/16" Jamb Depth -
Pine - Prefinished White
---- White Vinyl Jamb Liner
Insulated Low E
---- W/Out Neat Clean Glass
Glazing Bead Type - Colonial
---- W/Out Protective Film
---- Tempered All Sash
---- Silver Spacer
---- W/Inert Airspace Gas
1 Lite -
White - Double Locks -
---- No Jamb Jack Screws
W/Full Screen - White - NO-SEE-UM Mesh - Shipped Loose
Standard Unit
No Field Prepping

D1

(Viewed from Exterior)

Rough Opening 31-1/2" x 62"
Overall Jamb 30-1/2" x 61-1/2"

Lead Time: 5 Weeks

WEATHER SHIELD.

WINDOWS & DOORS

P.O. Box 309 Medford, WI 54451
weathershield.com

QUOTE

Printed: 08/05/2020 05:05 PM
Project Date: 08/05/2020

Quote #: 2389067
Quote Date: 08/05/2020
WSOneSource 1.0

LINE #	QUANTITY	ATTRIBUTES	UNIT	EXTENDED
--------	----------	------------	------	----------

19 1 P.O.:
Location: ATTIC
Job: 1035 CLARK

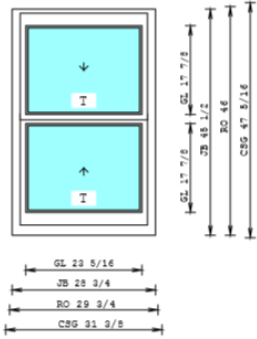

Weather Shield Double Hung Tilt Rectangle 610 1 Wide Complete Unit
 ----- Mfg Date 8/8/2008 to Present
 ----- Frame Style Double Hung
 See weathershield.com for PG/DP information
 Sizing Method Jb to Jb/Frame Size - Even
 ----- R/O Size 29 3/4" X 46"
 ----- Jamb Size 28 3/4" X 45 1/2"
 Venting R/O - Top 23" Venting R/O - Btm 23"
 ----- Glass Size - Top 23 5/16" X 17 7/8" - Bottom 23 5/16" X 17 7/8"
 Operating Code - Operating
 Poly - - White
 ----- Exterior Panel/Sash Color White
 - Factory Applied
 ----- Standard Sillnose -
 ----- 5 1/2" Installation Clips - Factory Applied
 4 9/16" Jamb Depth -
 Pine - Prefinished White
 ----- White Vinyl Jamb Liner
 Insulated Low E
 ----- W/Out Neat Clean Glass
 Glazing Bead Type - Colonial
 ----- W/Out Protective Film
 ----- Tempered All Sash
 ----- Silver Spacer
 ----- W/Inert Airspace Gas
 1 Lite -
 White - Double Locks -
 ----- No Jamb Jack Screws
 W/Full Screen - White - NO-SEE-UM Mesh - Shipped Loose
 Standard Unit
 No Field Prepping

A2

(Viewed from Exterior)

Rough Opening 29-3/4" x 46"
Overall Jamb 28-3/4" x 45-1/2"

Lead Time: 5 Weeks

WEATHER SHIELD.

WINDOWS & DOORS

P.O. Box 309 Medford, WI 54451
weathershield.com

QUOTE

Printed: 08/05/2020 05:05 PM
Project Date: 08/05/2020

Quote #: 2389067
Quote Date: 08/05/2020
WSOneSource 1.0

LINE #	QUANTITY	ATTRIBUTES	UNIT	EXTENDED
--------	----------	------------	------	----------

20 1 P.O.:
Location: STAIRCASE
Job: 1035 CLARK

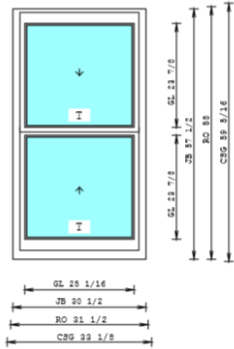

Weather Shield Double Hung Tilt Rectangle 610 1 Wide Complete Unit
 ----- Mfg Date 8/8/2008 to Present
 ----- Frame Style Double Hung
 See weathershield.com for PG/DP information
 Sizing Method Jb to Jb/Frame Size - Even
 ----- R/O Size 31 1/2" X 58"
 ----- Jamb Size 30 1/2" X 57 1/2"
 Venting R/O - Top 29" Venting R/O - Btm 29"
 ----- Glass Size - Top 25 1/16" X 23 7/8" - Bottom 25 1/16" X 23 7/8"
 Operating Code - Operating
 Poly - - White
 ----- Exterior Panel/Sash Color White
 - Factory Applied
 ----- Standard Sillnose -
 ----- 5 1/2" Installation Clips - Factory Applied
 4 9/16" Jamb Depth -
 Pine - Prefinished White
 ----- White Vinyl Jamb Liner
 Insulated Low E
 ----- W/Out Neat Clean Glass
 Glazing Bead Type - Colonial
 ----- W/Out Protective Film
 ----- Tempered All Sash
 ----- Silver Spacer
 ----- W/Inert Airspace Gas
 1 Lite -
 White - Double Locks -
 ----- No Jamb Jack Screws
 W/Full Screen - White - NO-SEE-UM Mesh - Shipped Loose
 Standard Unit
 No Field Prepping

B1

(Viewed from Exterior)

Rough Opening 31-1/2" x 58"
Overall Jamb 30-1/2" x 57-1/2"
Miscellaneous Charges

Lead Time: 5 Weeks

Thank you for choosing Weather Shield Windows & Doors

WEATHER SHIELD.

WINDOWS & DOORS

P.O. Box 309 Medford, WI 54451
weathershield.com

Message Summary

Printed: 08/05/2020 05:05 PM
Project Date: 08/05/2020

Quote #: 2389067
Quote Date: 08/05/2020
WSOneSource 1.0

<u>Message #</u>	<u>Line Item/s</u>	<u>Message</u>
------------------	--------------------	----------------