

DETROIT FREE PRESS BUILDING
321 W LAFAYETTE

LOCATOR MAP

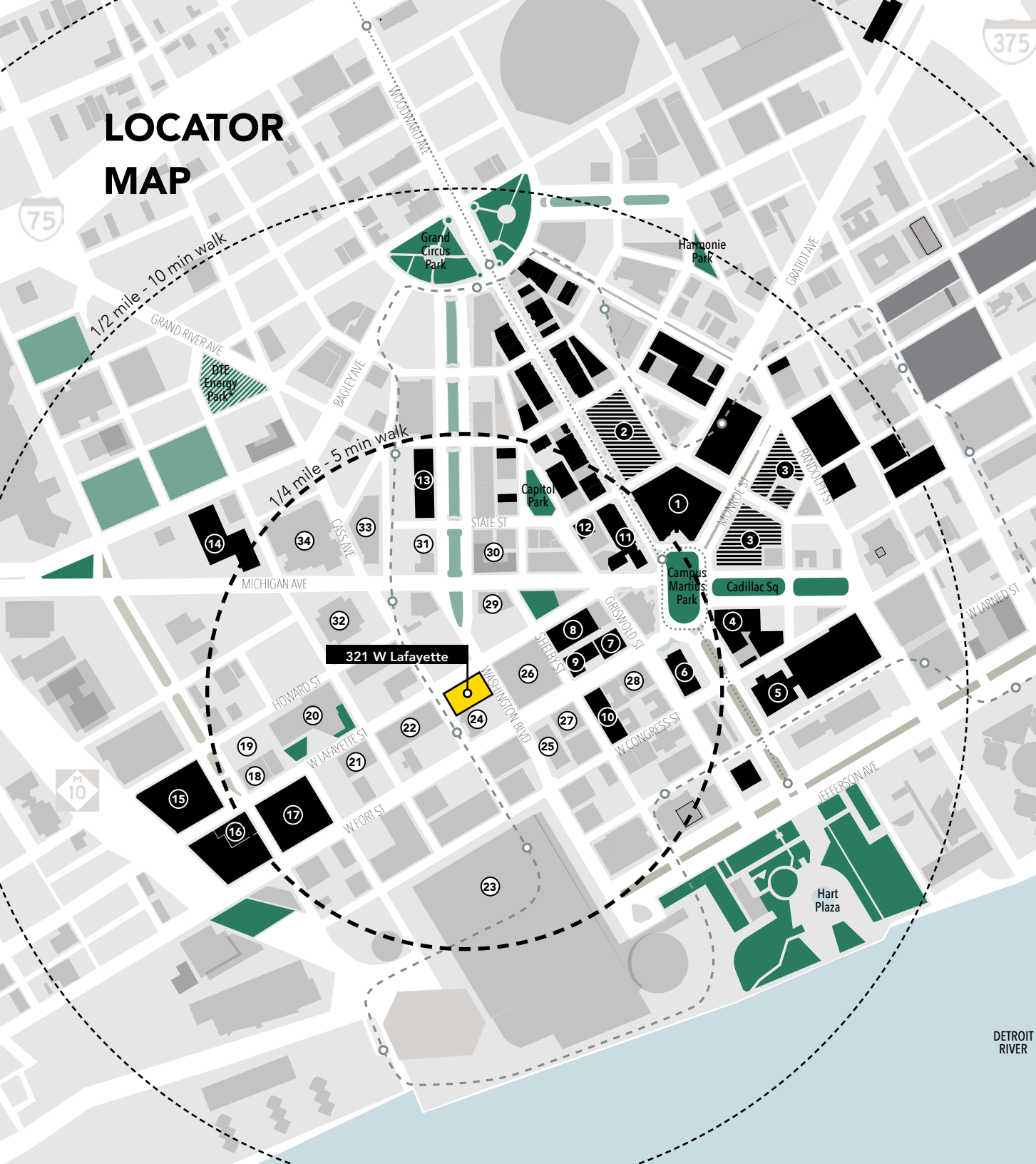

KEY

- PROPERTY OF FOCUS
- BEDROCK PROPERTIES
- JACK CASINO PROPERTIES

- PEOPLE MOVER / STATION
- M-1 RAIL / STATION

- 1 ONE CAMPUS MARTIUS
- 2 HUDSON'S SITE*
- 3 MONROE BLOCKS*
- 4 FIRST NATIONAL BUILDING
- 5 ALLY DETROIT CENTER
- 6 CHASE TOWER
- 7 CHRYSLER HOUSE
- 8 FINANCIAL DISTRICT GARAGE
- 9 FEDERAL RESERVE BUILDING
- 10 SILVERS BUILDING
- 11 1001 WOODWARD
- 12 DAVID STOTT BUILDING
- 13 BOOK TOWER
- 14 MICHIGAN AVENUE GARAGE
- 15 HOWARD STREET LOT
- 16 KAHN GARAGE
- 17 615 W LAFAYETTE STREET
- 18 WALKER-ROEHRIG BUILDING
- 19 THE ASHTON APARTMENTS*
- 20 CLICK-ON-IT DETROIT NEWS
- 21 DOUBLE TREE + FORT SHELBY APTS
- 22 COMERICA BANK
- 23 COBO HALL CONVENTION CENTER
- 24 THE DETROIT CLUB
- 25 211 W FORT
- 26 US DISTRICT COURT
- 27 COMERICA BANK BUILDING
- 28 PENOBSCOT BUILDING
- 29 HOLIDAY INN EXPRESS
- 30 WESTIN BOOK CADILLAC
- 31 WASHINGTON MIXED-USE DEVELOPMENT*
- 32 MCNAMARA FEDERAL BUILDING
- 33 ROSA PARKS TRANSIT CENTER
- 34 AT&T MICHIGAN HEADQUARTERS

* DEVELOPMENTS IN THE PIPELINE

321 W LAFAYETTE PROPERTY HISTORY

“DETROIT FREE PRESS BUILDING”

YEAR : 1925

ARCHITECT : Albert Kahn

STYLE : Art Deco

The 14-story Art Deco masterpiece housed the **Detroit Free Press newspaper**, including all of its associated operations, when it opened in 1925. The building, which also contained rentable retail and commercial space, was commissioned by Free Press owner E.D. Stair. Historic features include:

- Exterior limestone carvings by New York sculptor Ulysses Ricci
- Advertising Room murals depicting early Detroit history by Roy C. Gamble
- Private Cass Ave lobby and walkway with connection to the elite Detroit Club

On July 23, 1998, the Free Press left its home of nearly 75 years - where much of the city's best journalism had been created.



PROPERTY SUMMARY

321 W LAFAYETTE ST - FREE PRESS BUILDING

PARCEL AREA : 0.633 acres

GROSS FLOOR AREA : 271,858 square feet

FLOORS : 14 above-ground; 2 below-ground

OVERALL BLDG HEIGHT : 190ft

ZONING : Restricted Central Business District

HISTORICS :

- U.S. Historic District (Detroit Financial District
- Contributing Property)
- Michigan State Historic Site



EXISTING CONDITIONS | DETROIT FREE PRESS BUILDING



VIEW FROM ROOFTOP



LOBBY

ARCHITECTURAL DETAIL | DETROIT FREE PRESS BUILDING



321 W LAFAYETTE

EXTERIOR IMAGES



FRONT FACADE



LAFAYETTE ENTRANCE



ENTRY LANTERN



LIMESTONE MEDALLION



LIMESTONE CARVING



ROOFTOP VIEW

321 W LAFAYETTE

INTERIOR IMAGES



BASEMENT + MEZZANINE



1ST FLOOR AD ROOM



1ST FLOOR RETAIL SPACE



ELEVATOR LOBBY



UPPER FLOOR OFFICE



UPPER FLOOR OFFICE

HISTORY + VISION

321 W Lafayette's interior architecture is diverse, representing the building's history of accommodating all aspects of running a major newspaper. From soaring raw basements once home to printing presses to bright, elaborately ornamented lobbies and offices, the common thread between the spaces is their impressive historic atmosphere. With the right approach and creative vision, these spaces can be restored and enhanced to meet the needs of modern tenancy with respect for the landmark's legacy..

Authentic design that celebrates the past while reaching for the future.

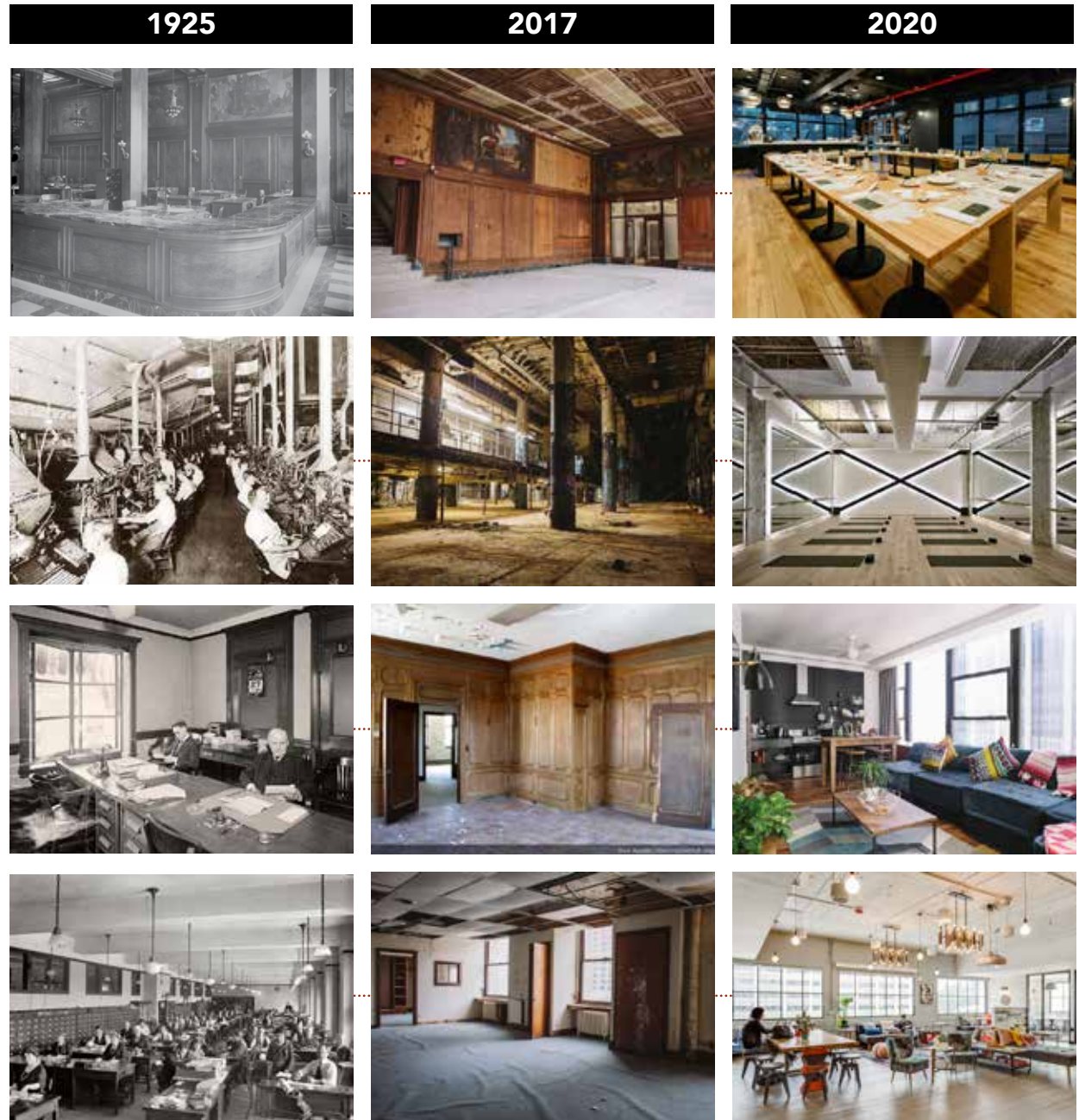

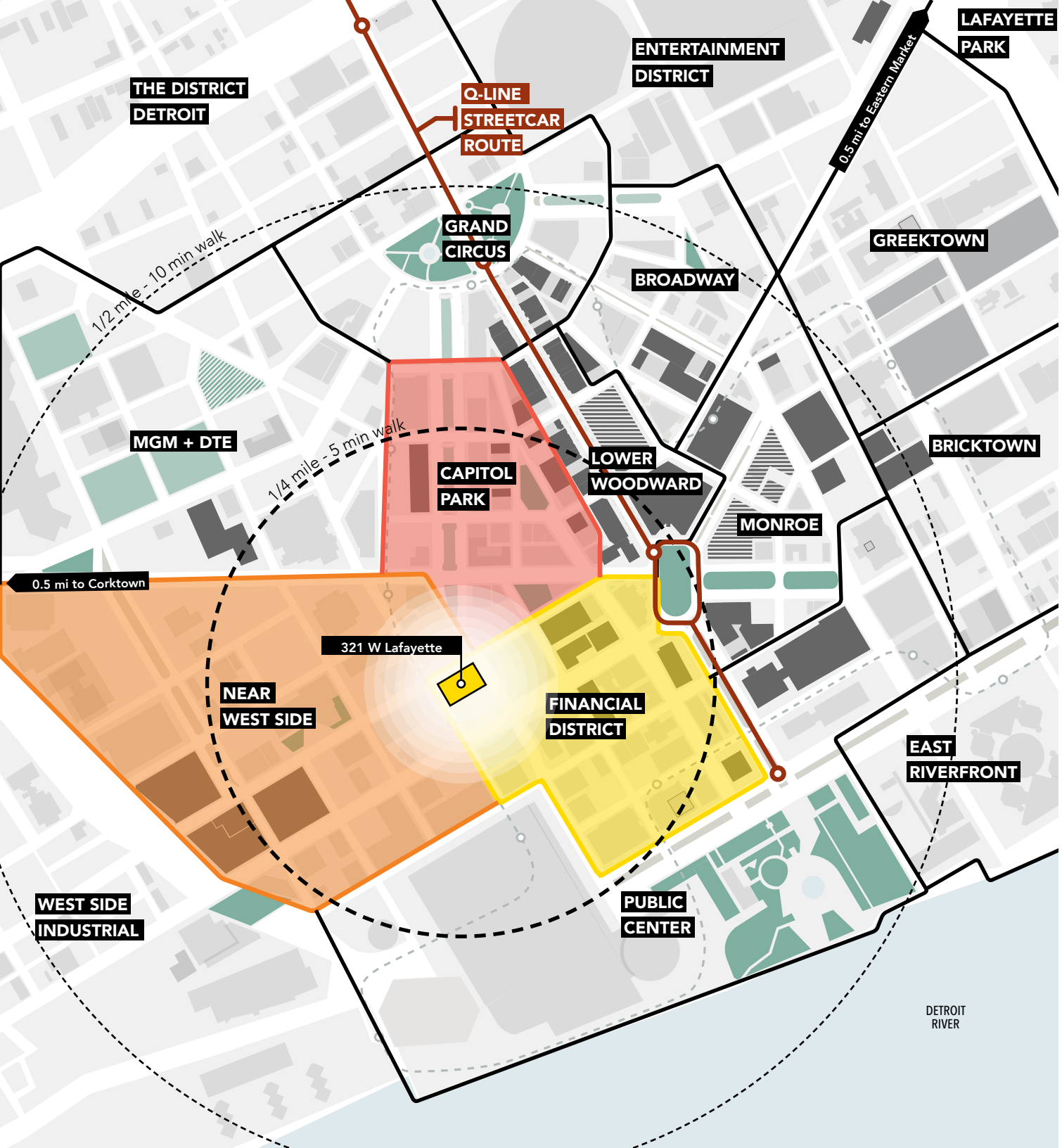

THE DISTRICTS OF DETROIT'S CBD

Each district within Detroit's Central Business District offers its own unique urban lifestyle. Located at the intersection of three burgeoning districts, 321 W Lafayette is strategically positioned to build off the growing momentum within each neighborhood.

PROPERTY POSITIONING

321 W LAFAYETTE - FREE PRESS BUILDING

321 W Lafayette is located at the intersection of three of Downtown's districts:

- West Side
- Capitol Park
- Financial District

This position affords the site the opportunity to capitalize on the unique characteristics of each of these bordering districts while creating its own identity as a crossroads between these hubs.

The location's walkability and nearby mobility assets--including protected bike lanes, Detroit People Mover stations, and bus routes--give 321 W Lafayette tremendous potential to become a connectivity hub both between these adjacent districts and beyond to the greater Downtown area.



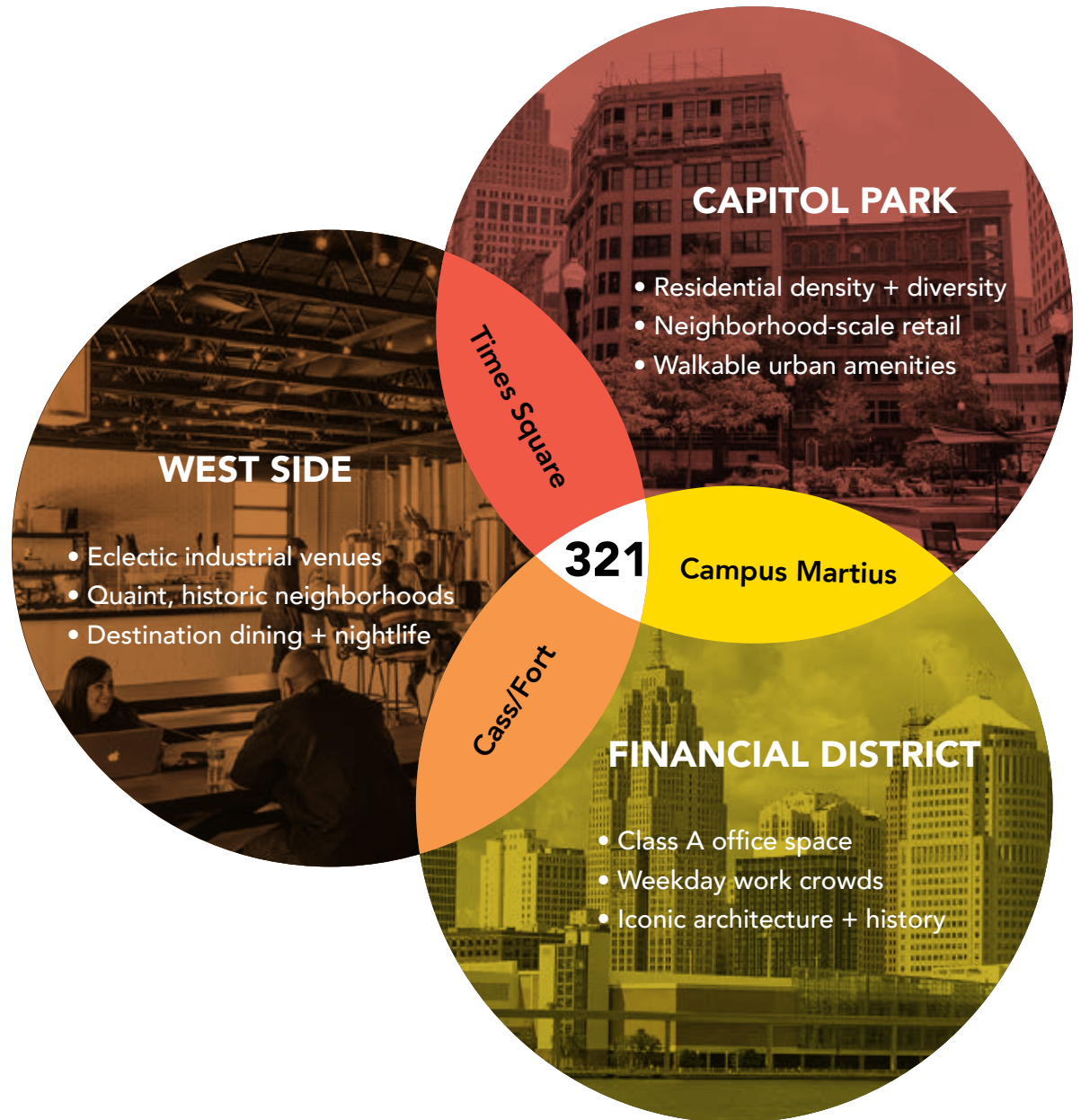

321 W Lafayette's selection as the location for the Detroit Free Press headquarters in 1924 was no accident; the property was at the center of activity in Downtown Detroit.



BUILDING SUMMARY | DETROIT FREE PRESS BUILDING

321 W. LAFAYETTE

POTENTIAL PROGRAMMING BREAKDOWN

GROSS FLOOR AREA:	243,211 SF
 RETAIL:	39,227 SF
 OFFICE:	52,088 SF
 BASEMENTS:	58,844 SF
 RESIDENTIAL:	93,052 SF (TEST-FIT PROGRAMS +/- 128 UNITS, BETWEEN 510 SF AND 1,200 SF EACH)

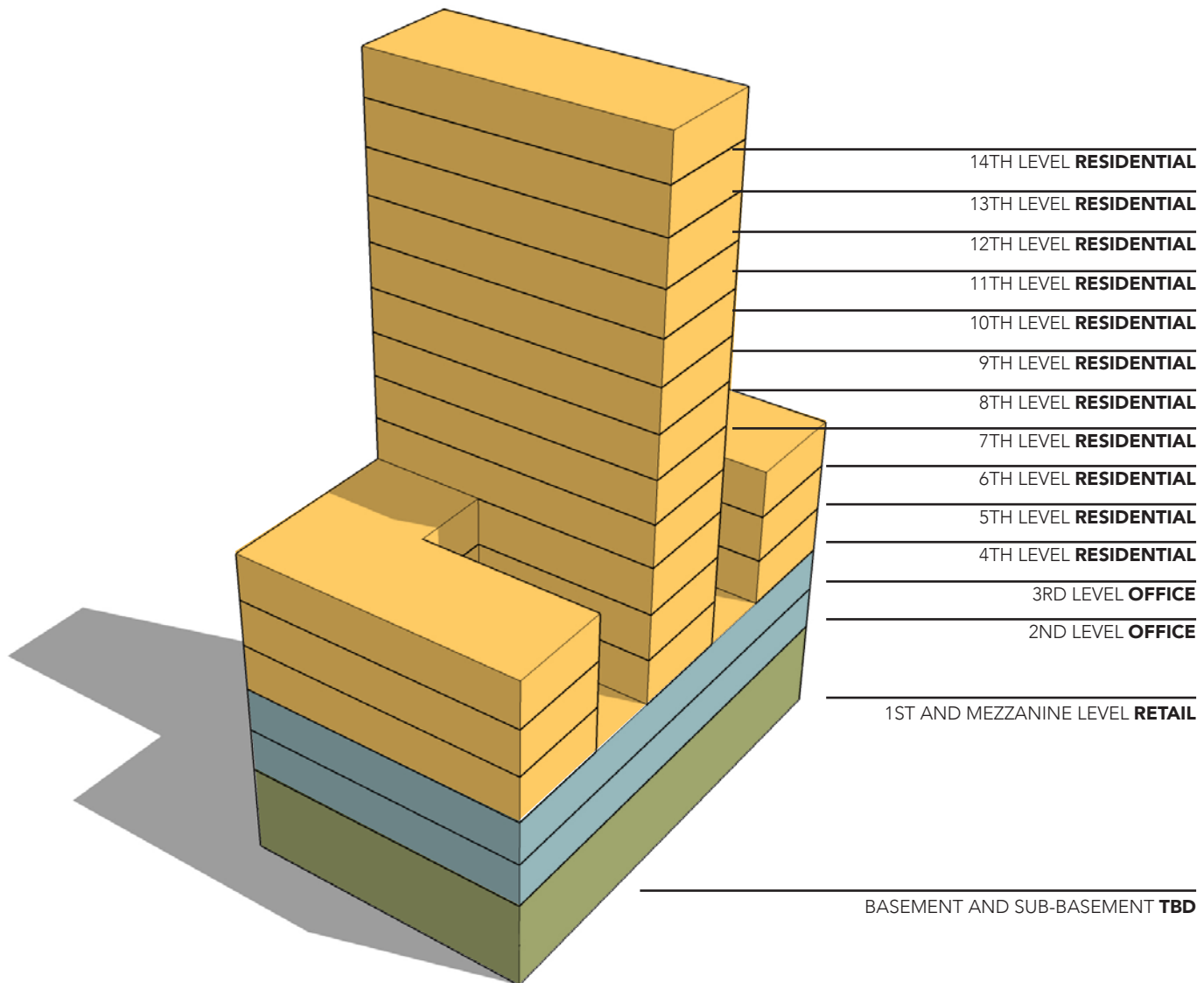

FLOOR PLAN CONCEPT

BASEMENT + SUB-BASEMENT

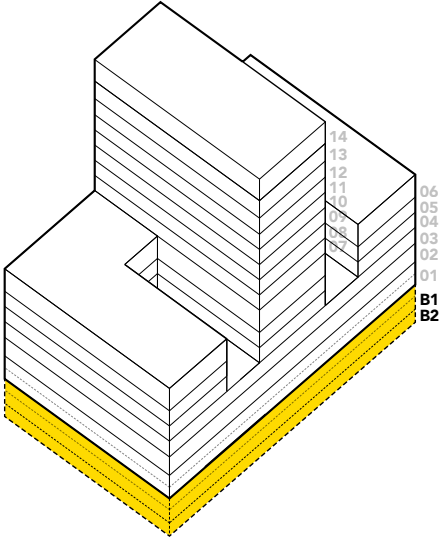

 COMMON	1,200 sf
 OFFICE	0 sf
 RETAIL/DINING	19,469 sf
 RESIDENTIAL	0 sf
 AMENITIES	11,780 sf
FLOOR AREA	32,449 sf

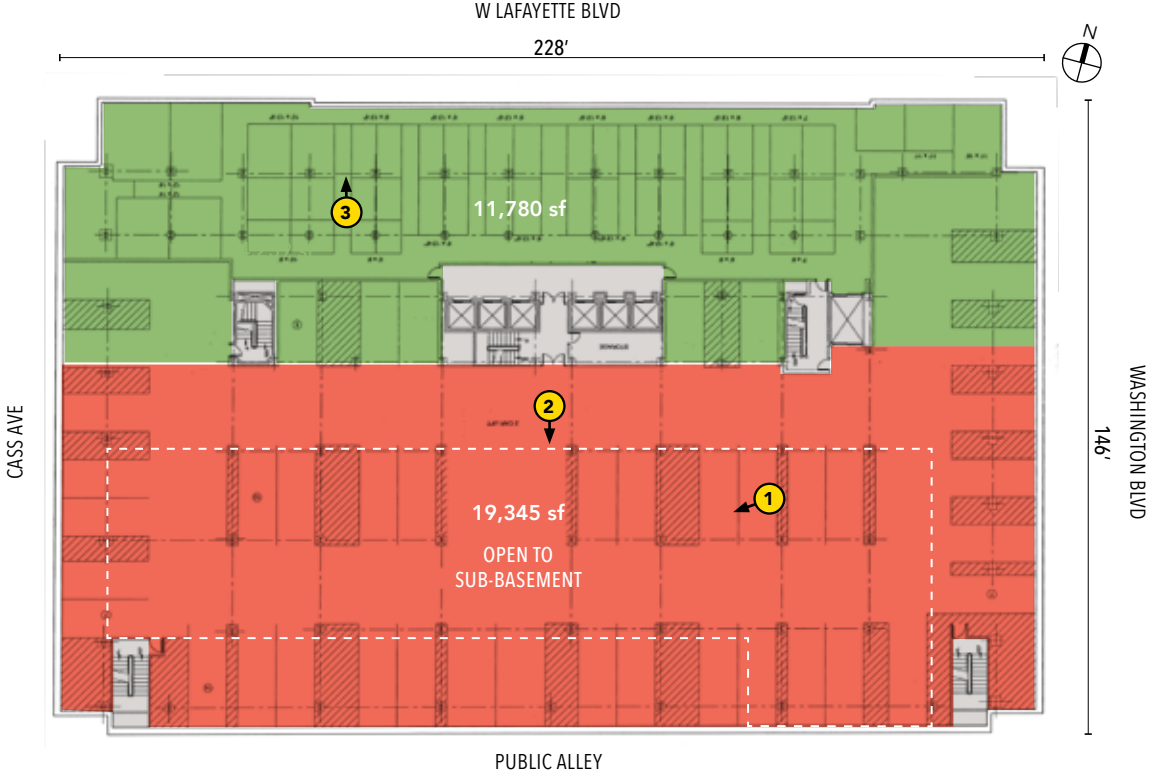

1 **SUB-BASEMENT**

The basement partially opens to a sub basement below, creating a soaring multistory space.



2 **PRESS ROOM**

The basement and sub basement housed all of the printing equipment until 1979.



3 **STORAGE**

The basement was originally for storage and mechanical, giving it a utilitarian design.

FLOOR PLAN CONCEPT

1ST FLOOR

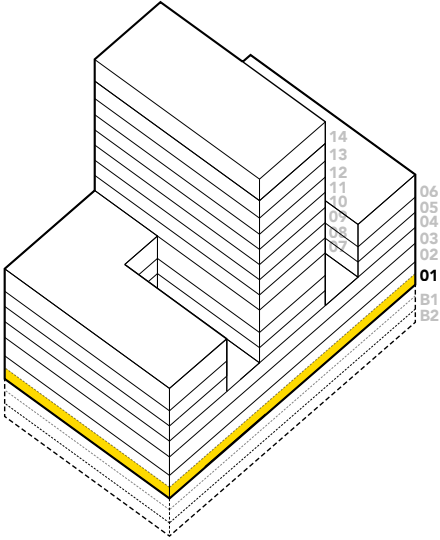

 COMMON	6,575 sf
 OFFICE	0 sf
 RETAIL/DINING	19,469 sf
 RESIDENTIAL	0 sf
 AMENITIES	0 sf
FLOOR AREA	26,044 sf

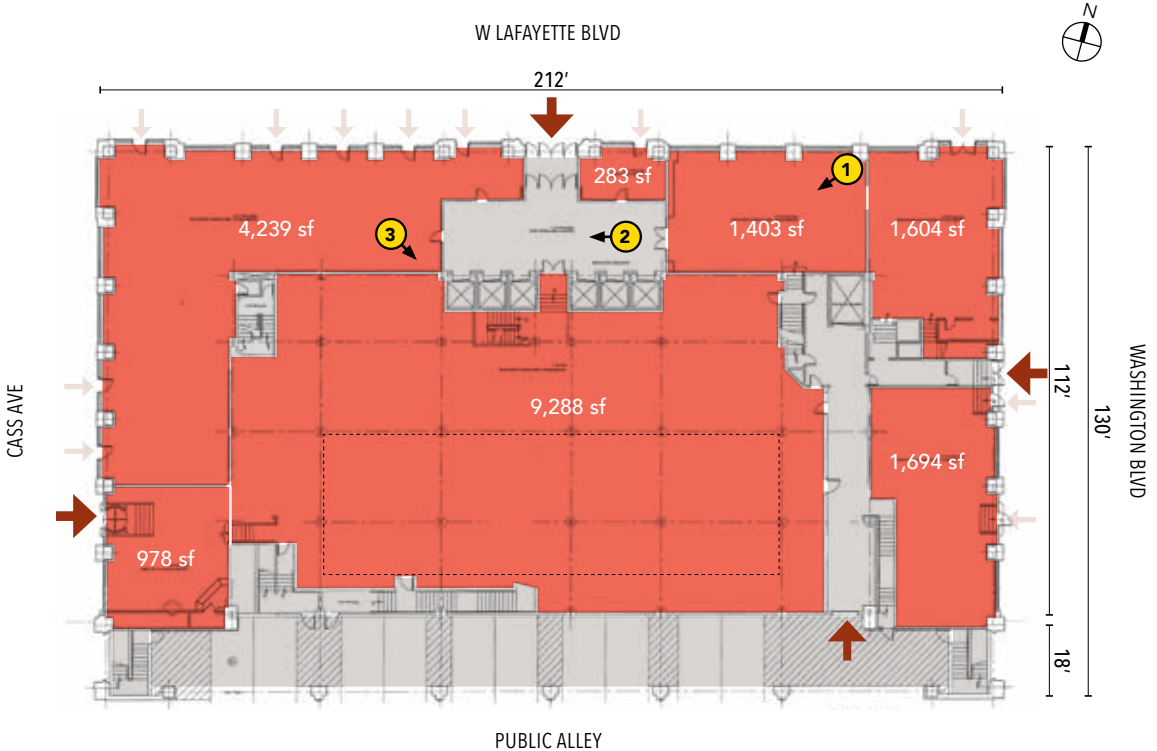

1 AD ROOM

Former ad room with original murals, wood paneling, terrazzo floors, and plaster ceiling.



2 LOBBY

The lobby's original terrazzo floors, marble walls, and plaster ceiling remain largely intact.



3 PRESS GALLEY

Press Galley employee cafe area off of main lobby on ground floor.

FLOOR PLAN CONCEPT

1ST FLOOR MEZZANINE

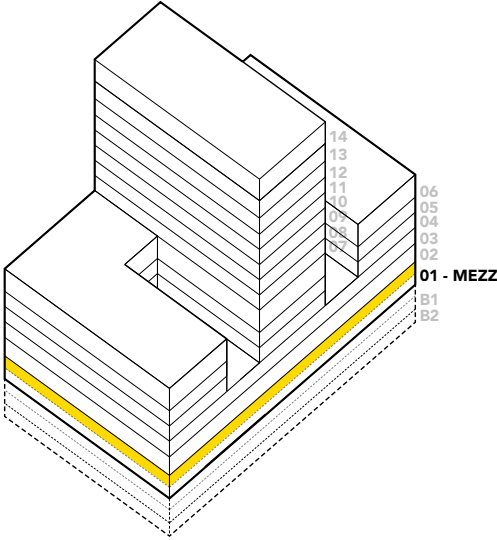

 COMMON	950 sf
 OFFICE	0 sf
 RETAIL/DINING	10,934 sf
 RESIDENTIAL	0 sf
 AMENITIES	0 sf
FLOOR AREA	11,884 sf

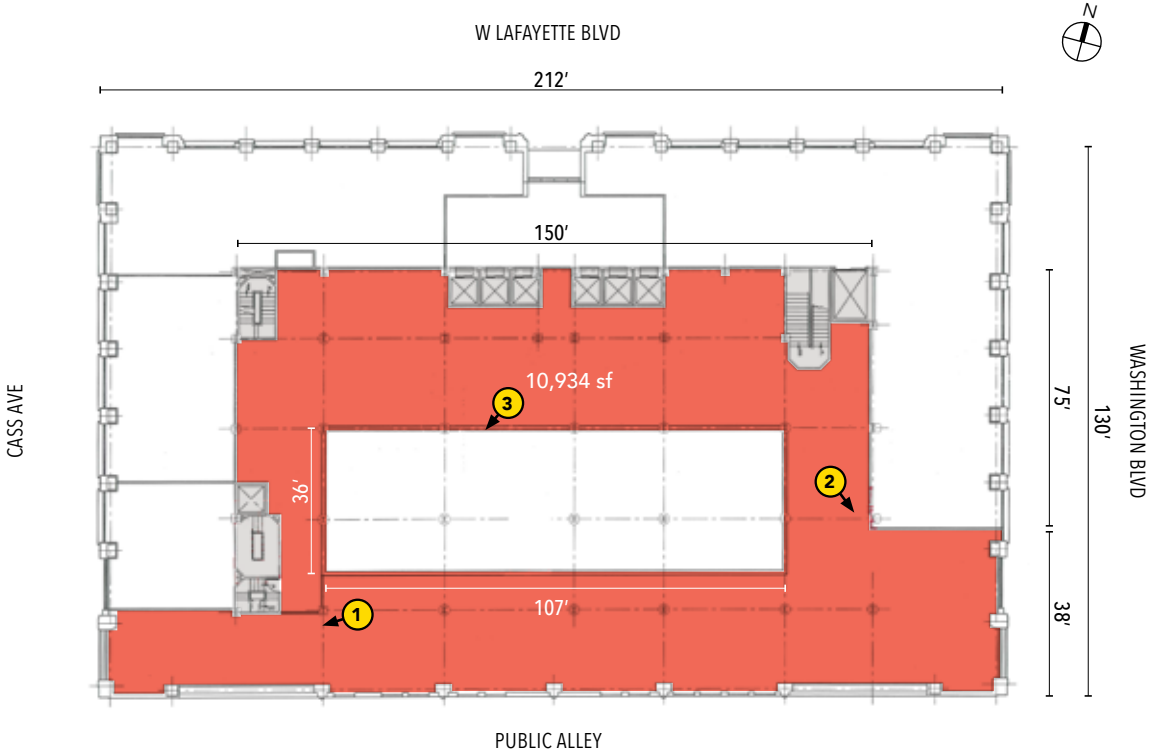

1 STORAGE

Storage area with low ceilings and cement floors surrounding the mezzanine.



2 SPIRAL STAIRCASE

One of two original spiral staircases leading up from the mailing room to the mezzanine.



3 MAILING ROOM

View down onto the original mailing room floor from the mezzanine level.

FLOOR PLAN CONCEPT

2ND - 3RD FLOOR

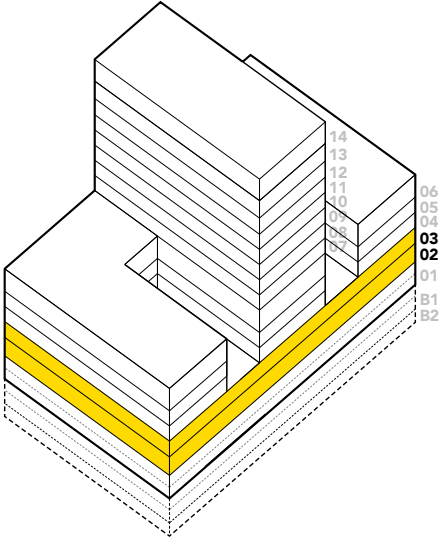

 COMMON	1,800 sf
 OFFICE	24,244 sf
 RETAIL/DINING	0 sf
 RESIDENTIAL	0 sf
 AMENITIES	0 sf
FLOOR AREA	26,044 sf

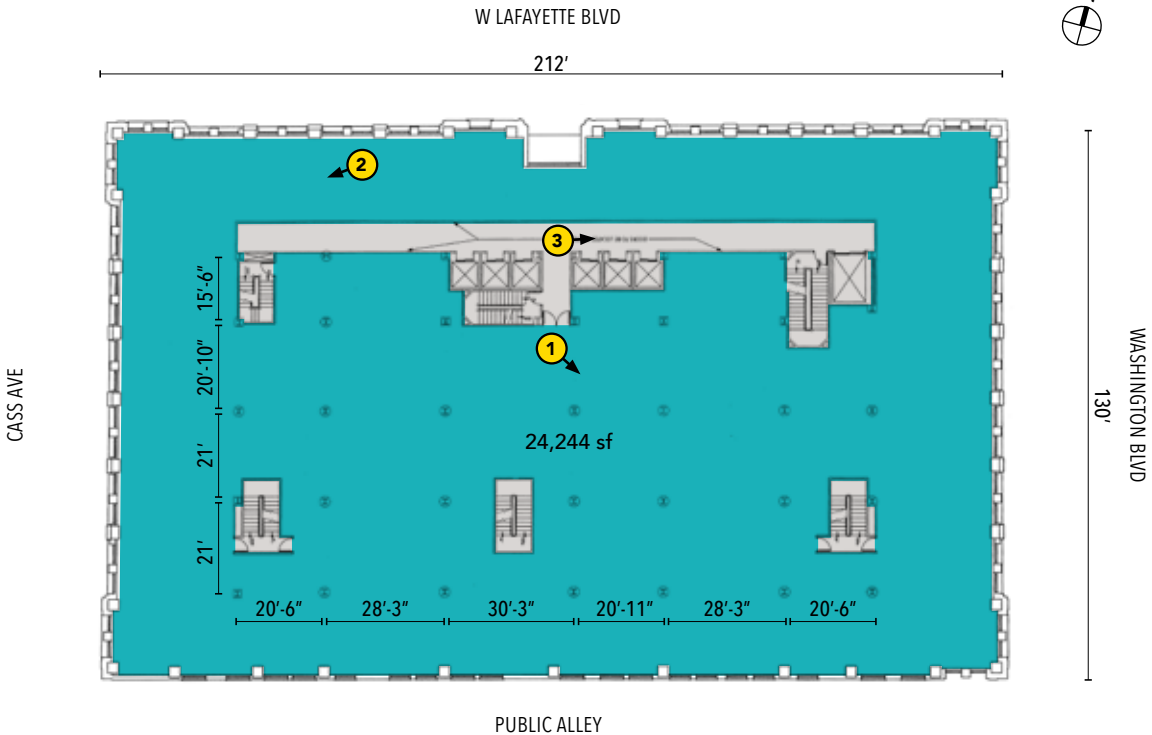

1 **OPEN OFFICE**

Original steel sash partitions have since been removed in the modernization of the office.



2 **OPEN OFFICE**

Large open rectangular floor plates allow light from the perimeter into the office.



3 **CORRIDOR**

Original marble wainscoting remains along the corridor off the elevator lobby.

FLOOR PLAN CONCEPT

4TH - 6TH FLOOR

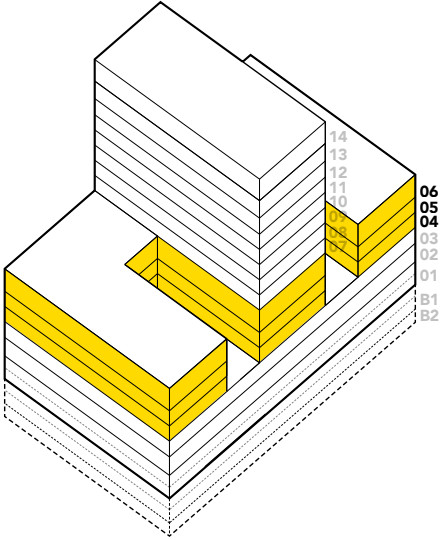

 COMMON	3,250 sf
 OFFICE	0 sf
 RETAIL/DINING	0 sf
 RESIDENTIAL	18,420 sf
 AMENITIES	0 sf
FLOOR AREA	21,670 sf

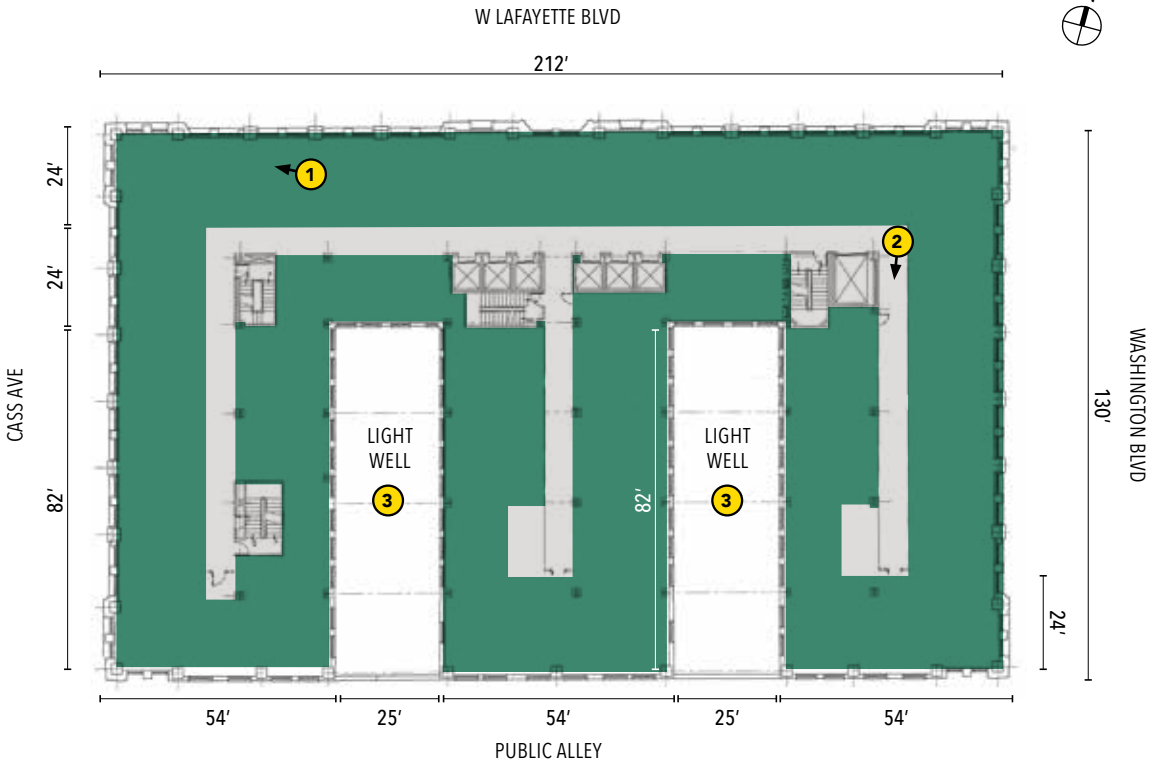

OFFICE

The corridors were originally lined with the wood-paneled offices of newspaper execs.



CORRIDOR

Double-loaded corridors line the E-shaped floor plate. Leasable offices originally lined each side.



LIGHTWELLS

Lightwells bring sun to interior units and were originally outfitted with skylights into floor 3.

FLOOR PLAN CONCEPT

7TH - 13TH FLOOR

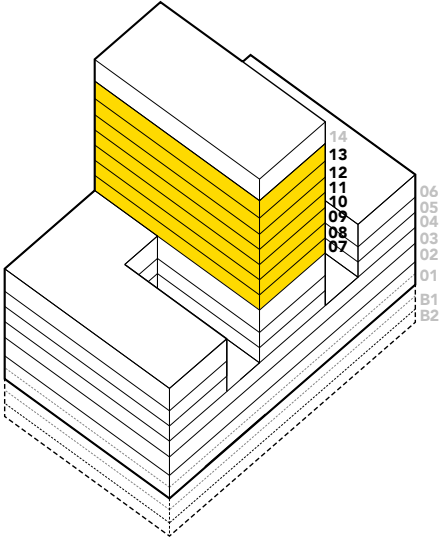

 COMMON	950 sf
 OFFICE	0 sf
 RETAIL/DINING	0 sf
 RESIDENTIAL	5,264 sf
 AMENITIES	0 sf
FLOOR AREA	6,214 sf

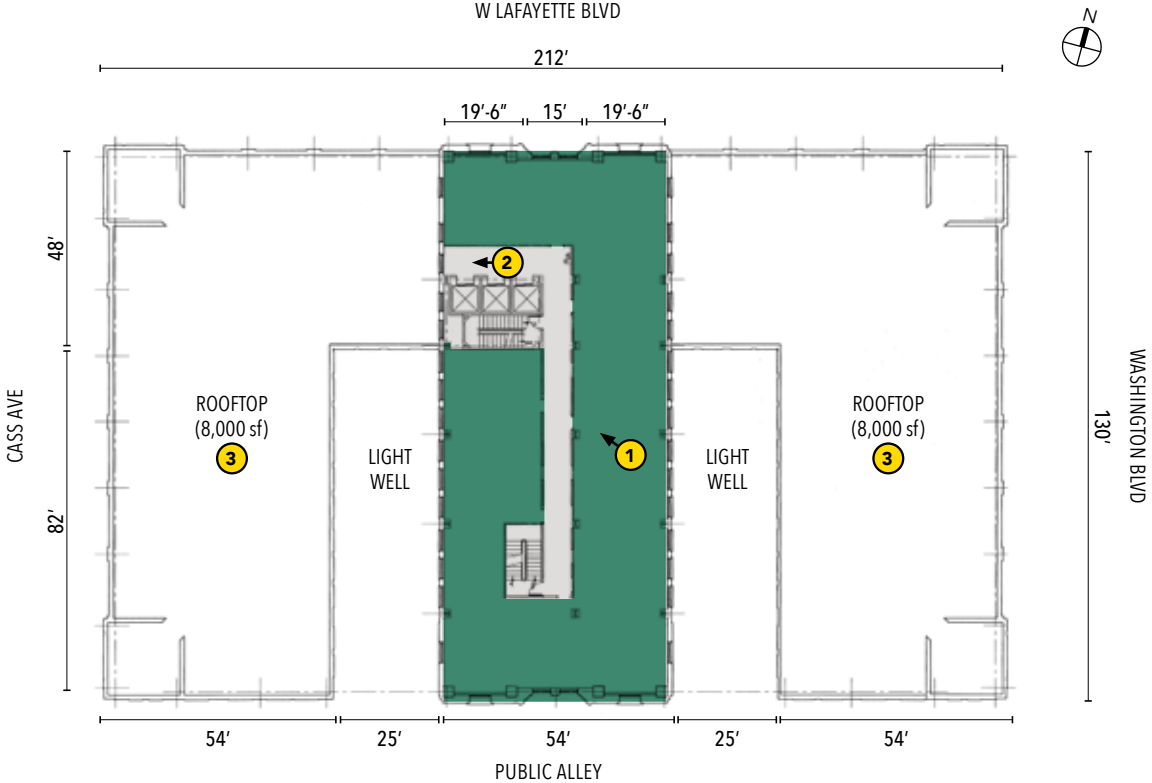

OFFICE

The 13th floor was home to the office of E.M. Stair, the building's original commissioner.



ELEVATOR LOBBY

Even on the uppermost floors, the marble wainscoting remains in the elevator lobbies.



ROOFTOP

Parts of the rooftop have been previously adapted for a rooftop deck with views of the city.

FLOOR PLAN CONCEPT

14TH FLOOR

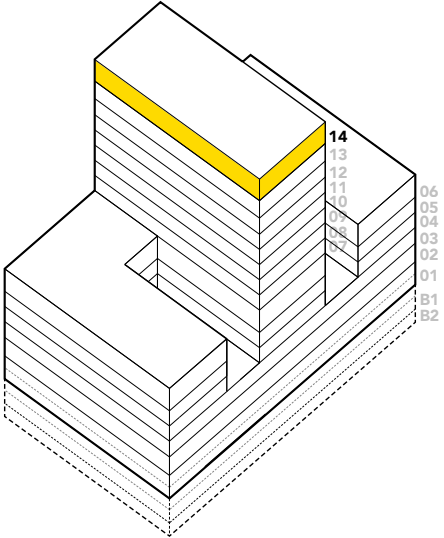

 COMMON	3,500 sf
 OFFICE	0 sf
 RETAIL/DINING	0 sf
 RESIDENTIAL	0 sf
 AMENITIES	0 sf
FLOOR AREA	3,500 sf

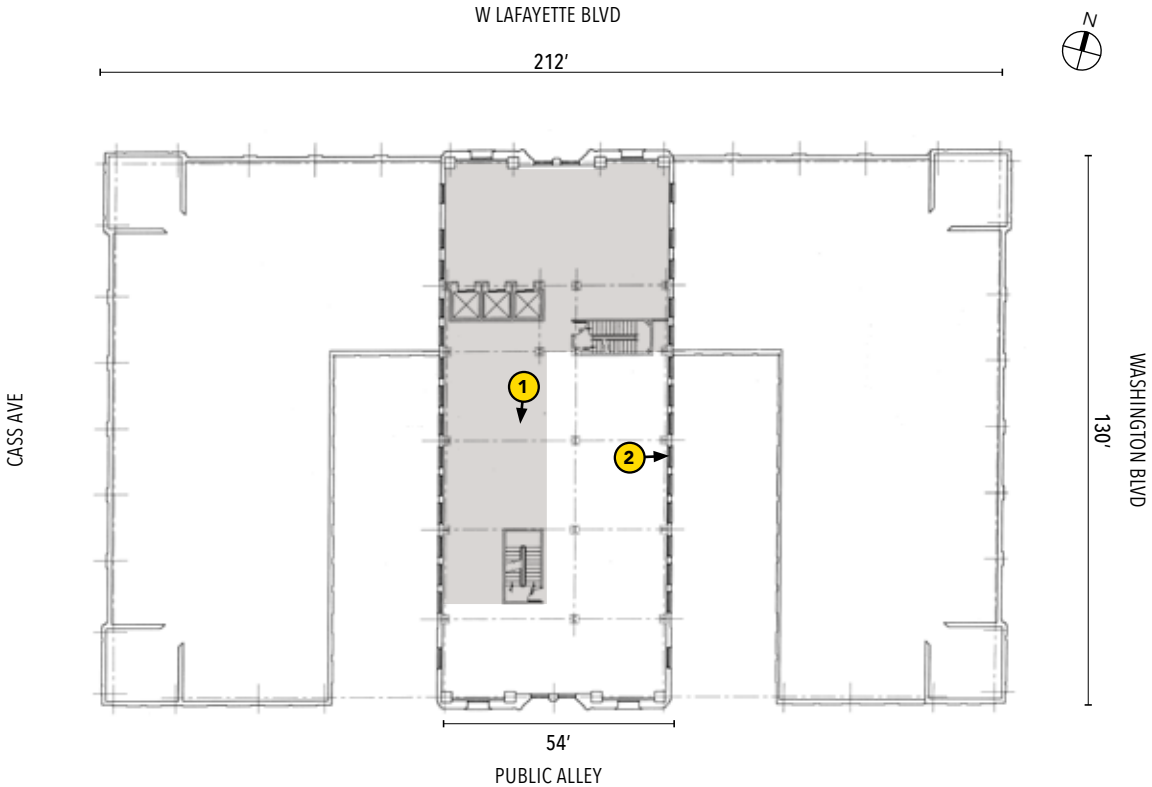

PENTHOUSE

The 14th floor was originally the mechanical penthouse with machinery and a radio room.



ROOFTOP

Panoramic view centered east from the uppermost rooftop, 190' above the street. Washington Blvd can be seen on the left, the main Central Business District ahead, and the Detroit River on the right.

FLOOR PLAN BREAKDOWN

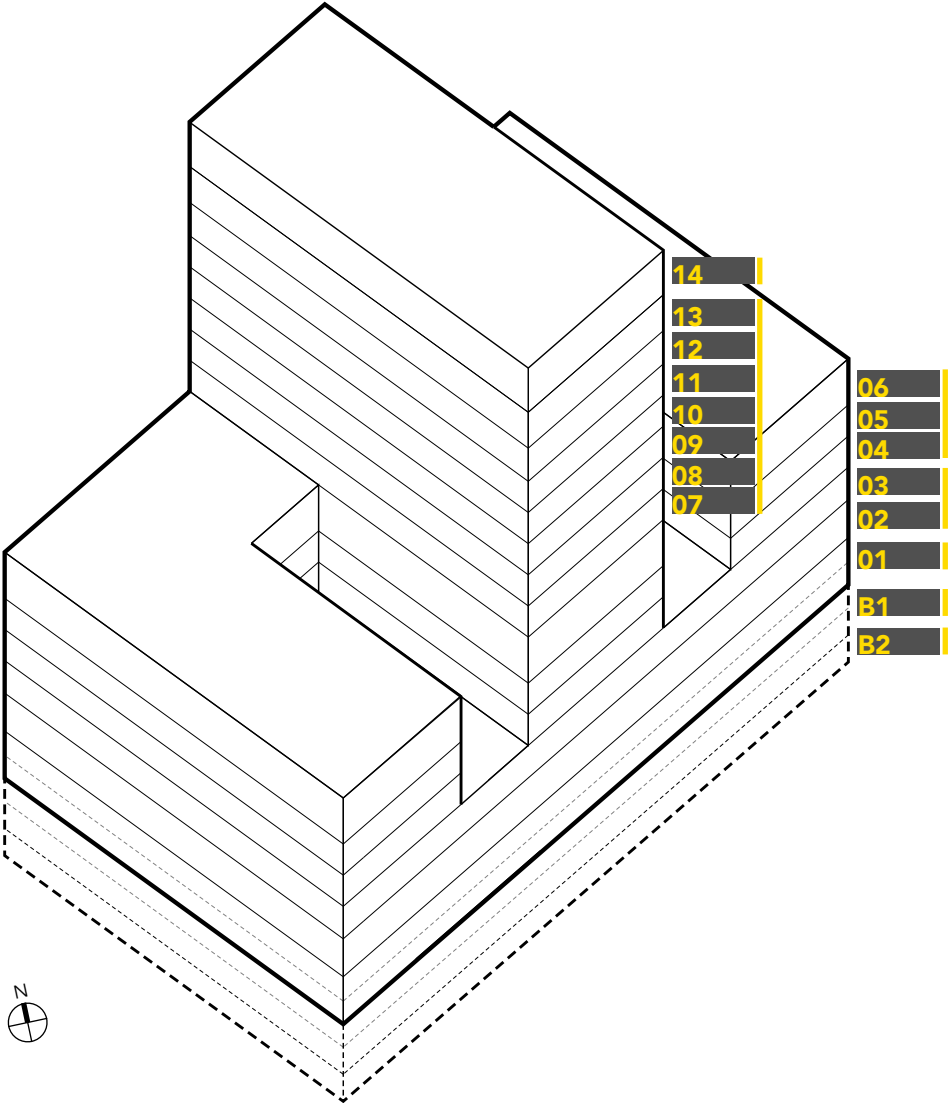

- 14TH FLOOR**
- Floor Height: 13'-6"
 - Floor Area: 3,500 sf

- 7TH - 13TH FLOORS**
- 7th-12th Floor Height: 11'-6"
 - 13th Floor Height: 12'-3"
 - Floor Area: 6,214 sf

- 4TH - 6TH FLOORS**
- 4th-5th Floor Height: 11'-6"
 - 6th Floor Height: 17'-0"
 - Floor Area: 21,670 sf

- 2ND - 3RD FLOORS**
- 2nd Floor Height: 14'-0"
 - 3rd Floor Height: 12'-0"
 - Floor Area: 26,044 sf

- 1ST FLOOR + 1ST FL MEZZANINE**
- Total Height: 17'-6"
 - Main Floor Height: 8'-6"
 - Mezzanine Height: 9'-0"
 - Main Floor Area: 27,135 sf
 - Mezzanine Floor Area: 11,884 sf
 - Total Floor Area: 39,019 sf

- BASEMENT + BASEMENT MEZZANINE**
- Total Height: 18'-6"
 - Main Floor Height: 10'-0"
 - Mezzanine Height: 8'-6"
 - Floor Area: 25,480 sf

- SUB-BASEMENT**
- Floor Height: 10'-0"
 - Floor Area: 33,364 sf